

# Service Manual

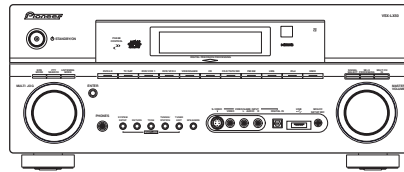

VSX-LX50

ORDER NO.  
**RRV3598**

**AUDIO/VIDEO MULTI-CHANNEL RECEIVER**

# VSX-LX50

## VSX-91TXH

## VSX-9120TXH-K

**THIS MANUAL IS APPLICABLE TO THE FOLLOWING MODEL(S) AND TYPE(S).**

Model	Type	Power Requirement	Remarks
VSX-LX50	HYXJ5	AC 220 V to 230V	
VSX-91TXH	KUXJ/CA	AC 120 V	
VSX-9120TXH-K	KUXJ	AC 120 V	



For details, refer to "Important Check Points for good servicing".

# SAFETY INFORMATION



This service manual is intended for qualified service technicians ; it is not meant for the casual do-it-yourselfer. Qualified technicians have the necessary test equipment and tools, and have been trained to properly and safely repair complex products such as those covered by this manual. Improperly performed repairs can adversely affect the safety and reliability of the product and may void the warranty. If you are not qualified to perform the repair of this product properly and safely, you should not risk trying to do so and refer the repair to a qualified service technician.

## WARNING

This product contains lead in solder and certain electrical parts contain chemicals which are known to the state of California to cause cancer, birth defects or other reproductive harm.

Health & Safety Code Section 25249.6 - Proposition 65



## NOTICE

(FOR CANADIAN MODEL ONLY)

Fuse symbols  (fast operating fuse) and/or  (slow operating fuse) on PCB indicate that replacement parts must be of identical designation.

## REMARQUE

(POUR MODÈLE CANADIEN SEULEMENT)

Les symboles de fusible  (fusible de type rapide) et/ou  (fusible de type lent) sur CCI indiquent que les pièces de remplacement doivent avoir la même désignation.

(FOR USA MODEL ONLY)

## 1. SAFETY PRECAUTIONS

The following check should be performed for the continued protection of the customer and service technician.

### LEAKAGE CURRENT CHECK

Measure leakage current to a known earth ground (water pipe, conduit, etc.) by connecting a leakage current tester such as Simpson Model 229-2 or equivalent between the earth ground and all exposed metal parts of the appliance (input/output terminals, screwheads, metal overlays, control shaft, etc.). Plug the AC line cord of the appliance directly into a 120V AC 60 Hz outlet and turn the AC power switch on. Any current measured must not exceed 0.5 mA.

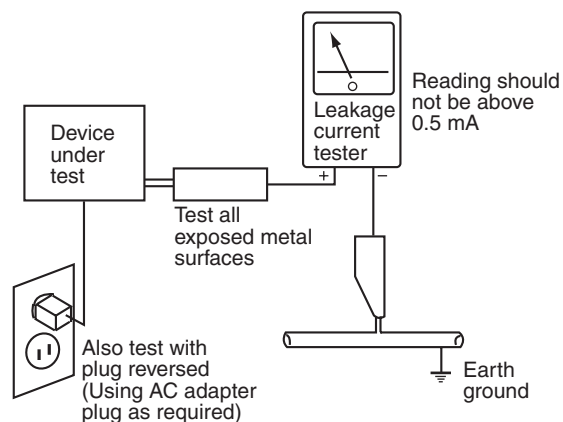

AC Leakage Test

**ANY MEASUREMENTS NOT WITHIN THE LIMITS OUTLINED ABOVE ARE INDICATIVE OF A POTENTIAL SHOCK HAZARD AND MUST BE CORRECTED BEFORE RETURNING THE APPLIANCE TO THE CUSTOMER.**

## 2. PRODUCT SAFETY NOTICE

Many electrical and mechanical parts in the appliance have special safety related characteristics. These are often not evident from visual inspection nor the protection afforded by them necessarily can be obtained by using replacement components rated for voltage, wattage, etc. Replacement parts which have these special safety characteristics are identified in this Service Manual.

Electrical components having such features are identified by marking with a  on the schematics and on the parts list in this Service Manual.

The use of a substitute replacement component which does not have the same safety characteristics as the PIONEER recommended replacement one, shown in the parts list in this Service Manual, may create shock, fire, or other hazards.

Product Safety is continuously under review and new instructions are issued from time to time. For the latest information, always consult the current PIONEER Service Manual. A subscription to, or additional copies of, PIONEER Service Manual may be obtained at a nominal charge from PIONEER.

## [Important Check Points for Good Servicing]

In this manual, procedures that must be performed during repairs are marked with the below symbol. Please be sure to confirm and follow these procedures.

### 1. Product safety



Please conform to product regulations (such as safety and radiation regulations), and maintain a safe servicing environment by following the safety instructions described in this manual.

- ① Use specified parts for repair.

Use genuine parts. Be sure to use important parts for safety.

- ② Do not perform modifications without proper instructions.

Please follow the specified safety methods when modification (addition/change of parts) is required due to interferences such as radio/TV interference and foreign noise.

- ③ Make sure the soldering of repaired locations is properly performed.

When you solder while repairing, please be sure that there are no cold solder and other debris. Soldering should be finished with the proper quantity. (Refer to the example)

- ④ Make sure the screws are tightly fastened.

Please be sure that all screws are fastened, and that there are no loose screws.

- ⑤ Make sure each connectors are correctly inserted.

Please be sure that all connectors are inserted, and that there are no imperfect insertion.

- ⑥ Make sure the wiring cables are set to their original state.

Please replace the wiring and cables to the original state after repairs. In addition, be sure that there are no pinched wires, etc.

- ⑦ Make sure screws and soldering scraps do not remain inside the product.

Please check that neither solder debris nor screws remain inside the product.

- ⑧ There should be no semi-broken wires, scratches, melting, etc. on the coating of the power cord.

Damaged power cords may lead to fire accidents, so please be sure that there are no damages. If you find a damaged power cord, please exchange it with a suitable one.

- ⑨ There should be no spark traces or similar marks on the power plug.

When spark traces or similar marks are found on the power supply plug, please check the connection and advise on secure connections and suitable usage. Please exchange the power cord if necessary.

- ⑩ Safe environment should be secured during servicing.

When you perform repairs, please pay attention to static electricity, furniture, household articles, etc. in order to prevent injuries. Please pay attention to your surroundings and repair safely.

### 2. Adjustments



To keep the original performance of the products, optimum adjustments and confirmation of characteristics within specification. Adjustments should be performed in accordance with the procedures/instructions described in this manual.

### 3. Lubricants, Glues, and Replacement parts



Use grease and adhesives that are equal to the specified substance. Make sure the proper amount is applied.

### 4. Cleaning



For parts that require cleaning, such as optical pickups, tape deck heads, lenses and mirrors used in projection monitors, proper cleaning should be performed to restore their performances.

### 5. Shipping mode and Shipping screws



To protect products from damages or failures during transit, the shipping mode should be set or the shipping screws should be installed before shipment. Please be sure to follow this method especially if it is specified in this manual.

# CONTENTS

- SAFETY INFORMATION..... 2
- 1. SERVICE PRECAUTIONS ..... 6
  - 1.1 NOTES ON SOLDERING ..... 6
- A 2. SPECIFICATIONS ..... 7
  - 2.1 ACCESSORIES ..... 7
  - 2.2 SPECIFICATIONS ..... 8
  - 2.3 PANEL FACILITIES..... 10
- 3. BASIC ITEMS FOR SERVICE..... 20
  - 3.1 CHECK POINTS AFTER SERVICING..... 20
  - 3.2 PCB LOCATIONS ..... 21
  - 3.3 JIGS LIST ..... 23
- 4. BLOCK DIAGRAM..... 24
  - 4.1 OVERALL WIRING DIAGRAM ..... 24
  - 4.2 BLOCK DIAGRAM for AUDIO BLOCK ..... 26
  - B 4.3 BLOCK DIAGRAM for VIDEO BLOCK..... 28
- 5. DIAGNOSIS..... 30
  - 5.1 DIAGNOSIS FLOWCHART ..... 30
  - 5.2 CIRCUIT DESCRIPTION ..... 70
- 6. SERVICE MODE ..... 72
  - 6.1 TEST MODE ..... 72
- 7. DISASSEMBLY ..... 75
- 8. EACH SETTING AND ADJUSTMENT ..... 82
  - 8.1 ADJUSTMENT ..... 82
  - 8.2 HOW TO UPDATE FIRMWARE..... 82
- 9. EXPLODED VIEWS AND PARTS LIST..... 88
  - 9.1 PACKING ..... 88
  - C 9.2 EXTERIOR SECTION..... 90
  - 9.3 CHASSIS SECTION ..... 92
  - 9.4 REAR SECTION ..... 94
  - 9.5 POWER AMP SECTION..... 98
  - 9.6 FRONT PANEL SECTION ..... 100
- 10. SCHEMATIC DIAGRAM..... 102
  - 10.1 AUDIO IN ASSY (1/2) ..... 102
  - 10.2 AUDIO IN (2/2) and 12V-REG ASSYS..... 104
  - 10.3 MAIN CONTROL ASSY (1/3)..... 106
  - 10.4 MAIN CONTROL (2/3), GUARD-C and GUARD-F ASSYS ..... 108
  - 10.5 MAIN CONTROL ASSY (3/3)..... 110
  - 10.6 DSP ASSY (1/4)..... 112
  - D 10.7 DSP ASSY (2/4)..... 114
  - 10.8 DSP ASSY (3/4)..... 116
  - 10.9 DSP ASSY (4/4)..... 118
  - 10.10 COMPOSITE ASSY ..... 120
  - 10.11 S-VIDEO and BRIDGE 2 ASSYS..... 122
  - 10.12 COMPONENT ASSY ..... 124
  - 10.13 DISPLAY, VOLUME and MULTI JOG ASSYS..... 126
  - 10.14 HEADPHONE, FRONT-IN, PRIMARY and TRANS 1 ASSYS..... 128
  - 10.15 TRANS 2-1, DIODE 1, VH TR, BRIDGE 1 and PS/SP ASSYS ..... 130
  - 10.16 TRANS 2-2, TRANS SIDE, LOCAL P-SUPPLY, DC/DC, IR I/O and VIDEO CONNECT ASSYS ..... 132
  - 10.17 POWER AMP-L, POSI 1-L and POSI 2-L ASSYS ..... 134
  - E 10.18 POWER AMP-R and POSI 1-R ASSYS..... 136
  - 10.19 POWER AMP IN and POWER PROTECT ASSYS ..... 138
  - 10.20 HDMI & DVC ASSY (1/2) ..... 140
  - 10.21 HDMI & DVC ASSY (2/2)..... 142
  - 10.22 USB ASSY (VSX-LX50 ONLY) ..... 144
- 11. PCB CONNECTION DIAGRAM..... 147
  - 11.1 AUDIO IN ASSY ..... 148
  - 11.2 12V-REG ASSY..... 152
  - 11.3 BRIDGE 2 ASSY ..... 153
  - 11.4 MAIN CONTROL ASSY ..... 154
  - 11.5 DSP ASSY ..... 158
  - 11.6 COMPOSITE ASSY ..... 162
  - F 11.7 S-VIDEO ASSY ..... 166
  - 11.8 COMPONENT ASSY ..... 170
  - 11.9 DISPLAY ASSY ..... 174
  - 11.10 VOLUME ASSY..... 178

11.11 HEADPHONE ASSY .....	179
11.12 MULTI JOG ASSY .....	180
11.13 FRONT-IN ASSY .....	184
11.14 PRIMARY ASSY .....	188
11.15 TRANS 1 ASSY .....	192
11.16 TRANS 2-1 ASSY .....	193
11.17 DIODE 1 and VH TR ASSYS.....	194
11.18 BRIDGE 1 ASSY.....	195
11.19 PS/SP ASSY.....	196
11.20 TRANS 2-2 ASSY .....	200
11.21 POSI 1-L, POSI 2-L and POSI 1-R ASSYS.....	201
11.22 TRANS SIDE ASSY.....	202
11.23 IR I/O ASSY .....	204
11.24 LOCAL P-SUPPLY ASSY .....	206
11.25 DC/DC ASSY .....	208
11.26 VIDEO CONNECT ASSY .....	210
11.27 POWER AMP-L ASSY .....	212
11.28 POWER AMP-R ASSY .....	216
11.29 POWER AMP IN ASSY .....	220
11.30 POWER PROTECT ASSY.....	222
11.31 HDMI & DVC ASSY .....	224
11.32 USB ASSY (VSX-LX50 ONLY) .....	228
12. PCB PARTS LIST.....	230

A  
B  
C  
D  
E  
F

# 1. SERVICE PRECAUTIONS

## 1.1 NOTES ON SOLDERING

- A
- For environmental protection, lead-free solder is used on the printed circuit boards mounted in this unit.  
Be sure to use lead-free solder and a soldering iron that can meet specifications for use with lead-free solders for repairs accompanied by reworking of soldering.
  - Compared with conventional eutectic solders, lead-free solders have higher melting points, by approximately 40 °C.  
Therefore, for lead-free soldering, the tip temperature of a soldering iron must be set to around 373 °C in general, although the temperature depends on the heat capacity of the PC board on which reworking is required and the weight of the tip of the soldering iron.

Do NOT use a soldering iron whose tip temperature cannot be controlled.

- B
- Compared with eutectic solders, lead-free solders have higher bond strengths but slower wetting times and higher melting temperatures (hard to melt/easy to harden).

The following lead-free solders are available as service parts:

- Parts numbers of lead-free solder:
  - GYP1006 1.0 in dia.
  - GYP1007 0.6 in dia.
  - GYP1008 0.3 in dia.

C

D

E

F

## 2. SPECIFICATIONS

### 2.1 ACCESSORIES

#### ● Accessories

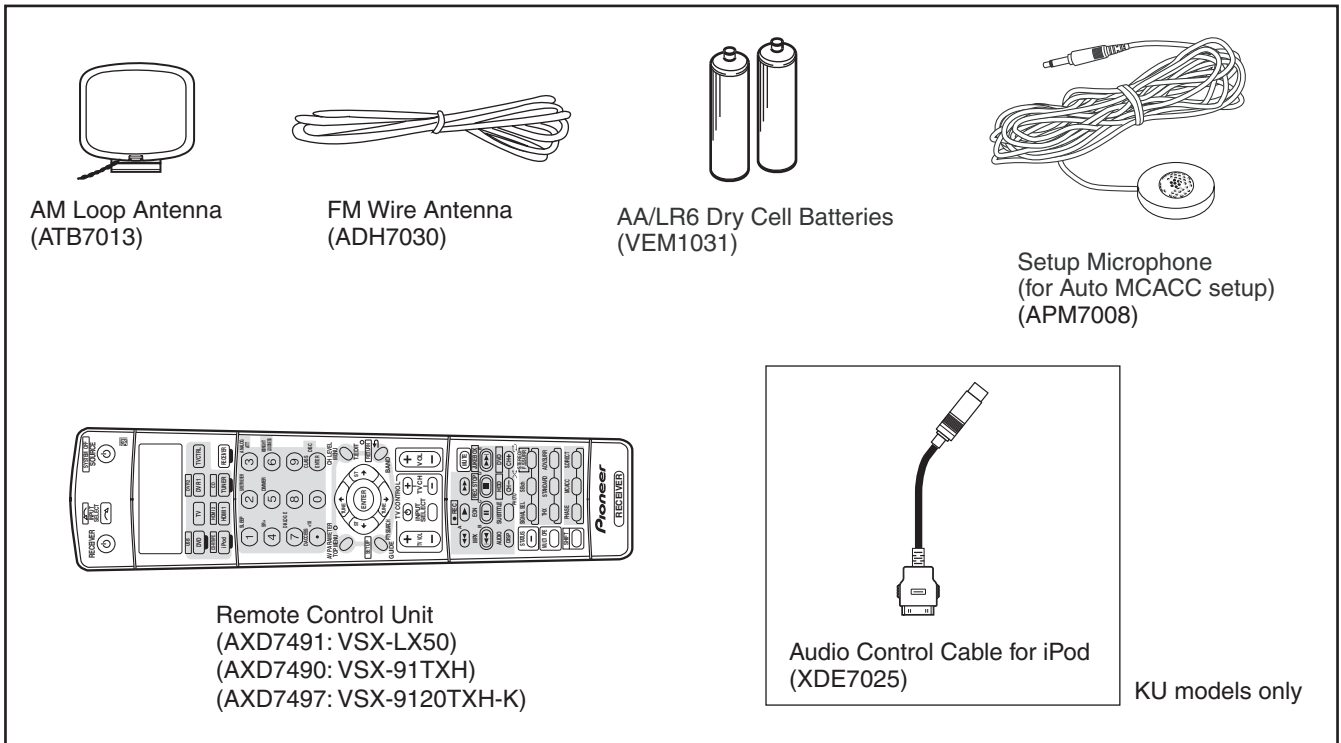

Windows Media™ and the Windows logo are trademarks or registered trademarks of Microsoft Corporation in the United States and/or other countries.

THX and the THX logo is a trademark of THX Ltd. which may be registered in some jurisdictions. All rights reserved.

Manufactured under license from Dolby Laboratories. "Dolby", "Pro Logic", "Surround EX", and the double-D symbol are trademarks of Dolby Laboratories.

"DTS" is a registered trademark of DTS, Inc. and "DTS-HD Master Audio" is a trademark of DTS, Inc.

## 2.2 SPECIFICATIONS

### ● VSX-LX50

#### A **Amplifier section**

##### Continuous Power Output (Stereo)

Front ..... 150 W + 150 W (DIN 1 kHz, THD 1 %, 6 Ω)  
120 W + 120 W (DIN 1 kHz, THD 1 %, 8 Ω)

##### Continuous Power Output (Multichannel)

Front ..... 150 W + 150 W (DIN 1 kHz, THD 1 %, 6 Ω)  
120 W + 120 W (DIN 1 kHz, THD 1 %, 8 Ω)  
Center ..... 150 W (DIN 1 kHz, THD 1 %, 6 Ω)  
120 W (DIN 1 kHz, THD 1 %, 8 Ω)  
Surround... 150 W + 150 W (DIN 1 kHz, THD 1 %, 6 Ω)  
120 W + 120 W (DIN 1 kHz, THD 1 %, 8 Ω)

##### Surround back

..... 150 W + 150 W (DIN 1 kHz, THD 1 %, 6 Ω)  
120 W + 120 W (DIN 1 kHz, THD 1 %, 8 Ω)

Rated Power Output ..... 130 W + 130 W  
(20 Hz to 20 kHz, 0.09 %, 6 Ω)

Rated Power Output ..... 110 W + 110 W  
(20 Hz to 20 kHz, 0.09 %, 8 Ω)

- The above specifications are applicable when the power supply is 230V.

#### **Audio Section**

##### Input (Sensitivity/Impedance)

LINE ..... 335 mV/47 kΩ

Frequency Response(LINE) ..... 5 Hz to 100 000 Hz  $\pm 0.5$  dB

##### Output (Level/Impedance)

REC ..... 335 mV/2.2 kΩ

##### Tone Control

BASS .....  $\pm 6$  dB (100 Hz)

TREBLE .....  $\pm 6$  dB (10 kHz)

LOUDNESS ..... +4 dB / +2 dB (100 Hz/10 kHz)  
(at volume position -40 dB)

##### Signal-to-Noise Ratio (IHF, short circuited, A network)

LINE ..... 103 dB

##### Signal-to-Noise Ratio

[DIN (continuous rated power output/50 mW)]

LINE ..... 92 dB / 65 dB

#### **Composite Video / S-Video Section**

Input (Sensitivity/Impedance) ..... 1 Vp-p/75 Ω

Output (Level/Impedance) ..... 1 Vp-p/75 Ω

Signal-to-Noise Ratio ..... 65 dB

Frequency Response ..... 5 Hz to 10 MHz

#### **Component Video Section**

Input (Sensitivity/Impedance) ..... 1 Vp-p/75 Ω

Output (Level/Impedance) ..... 1 Vp-p/75 Ω

Signal-to-Noise Ratio ..... 65 dB

Frequency Response ..... 5 Hz to 100 MHz

#### **FM Tuner Section**

Frequency Range ..... 87.5 MHz to 108 MHz

Usable Sensitivity ..... Mono: 15.2 dBf, IHF (1.6 μV/75 Ω)

50 dB Quieting Sensitivity ..... Mono: 20.2 dBf

Stereo: 41.2 dBf

Sensitivity (DIN) ..... Mono: 1.1 μV (S/N 26 dB)

Stereo: 50 μV (S/N 46 dB)

Signal-to-Noise Ratio ..... Mono: 76 dB (at 85 dBf)

Stereo: 72 dB (at 85 dBf)

Signal-to-Noise Ratio (DIN) ..... Mono: 62 dB

Stereo: 58 dB

Distortion ..... Stereo: 0.6 % (1 kHz)

Alternate Channel Selectivity ..... 70 dB (400 kHz)

Stereo Separation ..... 40 dB (1 kHz)

Frequency Response ..... 30 Hz to 15 kHz  $\pm 1$  dB

Antenna Input ..... 75 Ω unbalanced

#### **AM Tuner Section**

Frequency Range ..... 531 kHz to 1602 kHz (9 kHz step)

Sensitivity (IHF, Loop antenna) ..... 350 μV/m

Selectivity ..... 30 dB

Signal-to-Noise Ratio ..... 50 dB

Antenna ..... Loop antenna

#### **Miscellaneous**

Power Requirements ...AC 220 V to 230 V, 50 Hz / 60 Hz

Power Consumption ..... 450 W

In standby ..... 0.6 W

Dimensions ..... 420 (W) mm x 173 (H) mm x 465 (D) mm

Weight (without package) ..... 15.3 kg

#### **Furnished Parts**

Setup microphone (for Auto MCACC setup) ..... 1

AA/IEC R6P dry cell batteries ..... 2

Remote control unit ..... 1

AM loop antenna ..... 1

FM wire antenna ..... 1

Warranty card ..... 1

Operating instructions



#### **Note**

- Specifications and the design are subject to possible modifications without notice, due to improvements.

## ● VSX-91TXH/VSX-9120TXH-K

### Amplifier section

Continuous average power output of 110 watts\* per channel, min., at 8 ohms, from 20 Hz to 20 000 Hz with no more than 0.09 %\*\* total harmonic distortion (front).

Continuous Power Output (20 Hz to 20 kHz, 8 Ω, 0.09 %)

Front ..... 110 W + 110 W  
Center ..... 110 W  
Surround ..... 110 W + 110 W  
Surround back ..... 110 W + 110 W

Continuous Power Output (1 kHz, 6 Ω, 1.0 %)

Front ..... 150 W + 150 W  
Center ..... 150 W  
Surround ..... 150 W + 150 W  
Surround back ..... 150 W + 150 W

Total harmonic distortion ..... 0.09 %  
(20 Hz to 20 kHz, 110 W, 8 Ω)

\* Measured pursuant to the Federal Trade Commission's Trade Regulation rule on Power Output Claims for Amplifiers

\*\* Measured by Audio Spectrum Analyzer

### Audio Section

Input (Sensitivity/Impedance)

LINE ..... 335 mV/47 kΩ

Frequency Response (LINE) ..... 5 Hz to 100 000 Hz  $\pm 0.3$  dB  
Output (Level/Impedance)

REC ..... 335 mV/2.2 kΩ

Tone Control

BASS .....  $\pm 6$  dB (100 Hz)

TREBLE .....  $\pm 6$  dB (10 kHz)

LOUDNESS ..... +4 dB / +2 dB (100 Hz/10 kHz)  
(at volume position -40 dB)

Signal-to-Noise Ratio (IHF, short circuited, A network)

LINE ..... 103 dB

Signal-to-Noise Ratio [EIA, at 1 W (1 kHz)]

LINE ..... 83 dB

### Composite Video / S-Video Section

Input (Sensitivity/Impedance) ..... 1 Vp-p/75 Ω

Output (Level/Impedance) ..... 1 Vp-p/75 Ω

Signal-to-Noise Ratio ..... 65 dB

Frequency Response ..... 5 Hz to 10 MHz

### Component Video Section

Input (Sensitivity/Impedance) ..... 1 Vp-p/75 Ω

Output (Level/Impedance) ..... 1 Vp-p/75 Ω

Signal-to-Noise Ratio ..... 65 dB

Frequency Response ..... 5 Hz to 100 MHz

### FM Tuner Section

Frequency Range ..... 87.5 MHz to 108 MHz

Usable Sensitivity ..... Mono: 13.2 dBf, IHF (1.3 μV/75 Ω)

50 dB Quieting Sensitivity ..... Mono: 20.2 dBf  
Stereo: 38.6 dBf

Signal-to-Noise Ratio ..... Mono: 73 dB (at 85 dBf)  
Stereo: 70 dB (at 85 dBf)

Distortion ..... Stereo: 0.5 % (1 kHz)

Alternate Channel Selectivity ..... 60 dB (400 kHz)

Stereo Separation ..... 40 dB (1 kHz)

Frequency Response ..... 30 Hz to 15 kHz  $\pm 1$  dB

Antenna Input ..... 75 Ω unbalanced

### AM Tuner Section

Frequency Range ..... 530 kHz to 1700 kHz

Sensitivity (IHF, Loop antenna) ..... 350 μV/m

Selectivity ..... 25 dB

Signal-to-Noise Ratio ..... 50 dB

Antenna ..... Loop antenna

### Miscellaneous

Power Requirements ..... AC 120 V, 60 Hz

Power Consumption ..... 490 W, 650 VA

In standby ..... 0.65 W

AC Outlet ..... (switched) 100 W MAX.

Dimensions ..... 420 (W) mm x 173 (H) mm x 465 (D) mm

(16 <sup>9</sup>/<sub>16</sub> (W) in. x 6 <sup>13</sup>/<sub>16</sub> (H) in. x 18 <sup>5</sup>/<sub>16</sub> (D) in.)

Weight (without package) ..... 15.3 kg (33 lbs 12 oz)

### Furnished Parts

Setup microphone (for Auto MCACC setup) ..... 1

AA/IEC R6P dry cell batteries ..... 2

Remote control unit ..... 1

AM loop antenna ..... 1

FM wire antenna ..... 1

Warranty card ..... 1

Operating instructions

(\*) Audio Control cable for iPod ..... 1



### Note

- Specifications and the design are subject to possible modifications without notice, due to improvements.

(\*) KU models only

## 2.3 PANEL FACILITIES

### ● Front Panel (VSX-LX50)

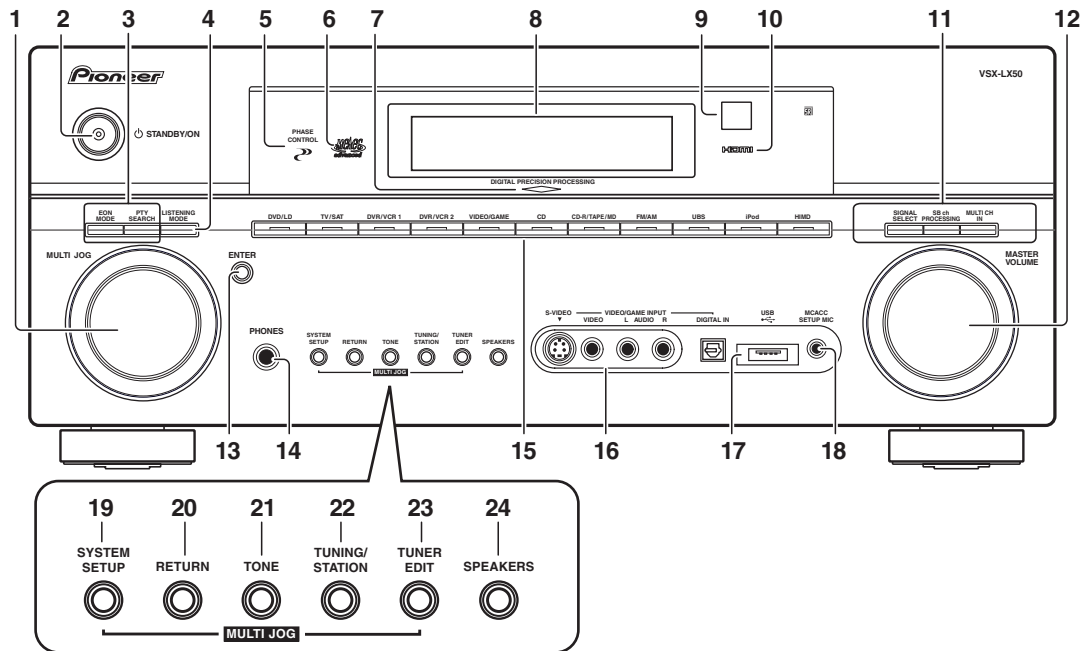

#### 1 MULTI JOG dial

Use the **MULTI JOG** dial to select various settings and menu options.

#### 2 **⏻** STANDBY/ON

Switches the receiver between on and standby. Power indicator lights when the receiver is on.

#### 3 EON MODE

Use to search for programs that are broadcasting traffic or news information.

#### PTY SEARCH

Use this button to search for RDS program types.

#### 4 LISTENING MODE

Use with the **MULTI JOG** dial to select the various listening modes.

#### 5 PHASE CONTROL indicator

Lights when the Phase Control is switched on.

#### 6 MCACC indicator

Lights when one of the MCACC presets is selected.

#### 7 DIGITAL PRECISION PROCESSING indicator

Lights to indicate digital processing.

#### 8 Character display

See Display on.

#### 9 Remote sensor

Receives the signals from the remote control.

#### 10 HDMI indicator

Blinks when connecting an HDMI-equipped component; lights when the component is connected.

#### 11 SIGNAL SELECT

Use to select an input signal.

**SB ch PROCESSING** – Selects the surround back channel mode or virtual surround back mode.

**MULTI CH IN** – Press to select the multichannel analog inputs.

#### 12 MASTER VOLUME dial

#### 13 ENTER

#### 14 PHONES jack

Use to connect headphones. When the headphones are connected, there is no sound output from the speakers.

#### 15 Input source buttons

Press to select an input source.

#### 16 VIDEO/GAME INPUT

#### 17 USB interface

Connect a USB audio device for playback.

#### 18 MCACC SETUP MIC jack

Use to connect the supplied microphone.

#### 19 SYSTEM SETUP

Press to access the System Setup menu.

#### 20 RETURN

Press to confirm and exit the current menu screen.

#### 21 TONE

Press this button to access the bass and treble controls, which you can then adjust with the **MULTI JOG** dial.

#### 22 TUNING/STATION

Use to find radio frequencies and to select preset stations.

#### 23 TUNER EDIT

Use with the **MULTI JOG** dial to memorize and name stations for recall.

#### 24 SPEAKERS

Use to change the speaker system.

## ● Front Panel (VSX-91TXH/VSX-9120TXH-K)

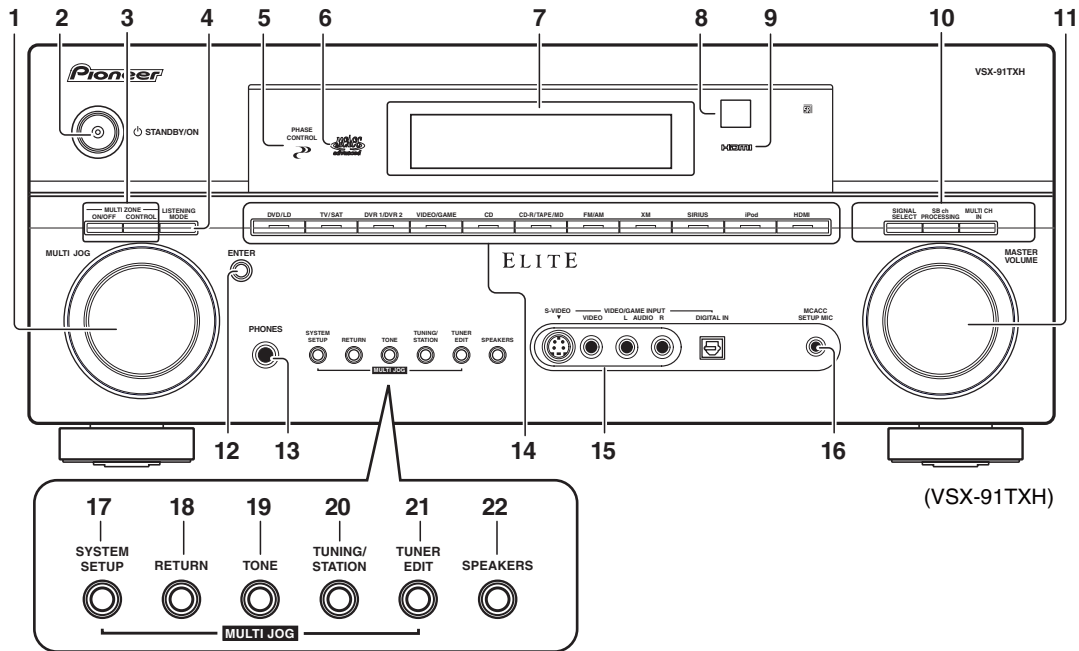

### 1 MULTI JOG dial

Use the **MULTI JOG** dial to select various settings and menu options.

### 2 STANDBY/ON

Switches the receiver between on and standby. Power indicator lights when the receiver is on.

### 3 MULTI ZONE controls

If you've made MULTI-ZONE connections use these controls to control the sub zone from the main zone.

### 4 LISTENING MODE

Use with the **MULTI JOG** dial to select the various listening modes.

### 5 PHASE CONTROL indicator

Lights when Phase Control is switched on.

### 6 MCACC indicator

Lights when one of the MCACC presets is selected.

### 7 Character display

### 8 Remote sensor

Receives the signals from the remote control.

### 9 HDMI indicator

Blinks when connecting an HDMI-equipped component; lights when the component is connected.

### 10 SIGNAL SELECT

Use to select an input signal.

**SB ch PROCESSING** – Selects the surround back channel mode or virtual surround back mode.

**MULTI CH IN** – Press to select the multichannel analog inputs.

### 11 MASTER VOLUME dial

### 12 ENTER

### 13 PHONES jack

Use to connect headphones. When the headphones are connected, there is no sound output from the speakers.

### 14 Input source buttons

Press to select an input source.

### 15 VIDEO/GAME INPUT

### 16 MCACC SETUP MIC jack

Use to connect the supplied microphone.

### 17 SYSTEM SETUP

Press to access the System Setup menu.

### 18 RETURN

Press to confirm and exit the current menu screen.

### 19 TONE

Press this button to access the bass and treble controls, which you can then adjust with the **MULTI JOG** dial.

### 20 TUNING/STATION

Use to find radio frequencies and to select preset stations.

### 21 TUNER EDIT

Use with the **MULTI JOG** dial to memorize and name stations for recall.

### 22 SPEAKERS

Use to change the speaker system.

## ● Rear Panel (VSX-LX50)

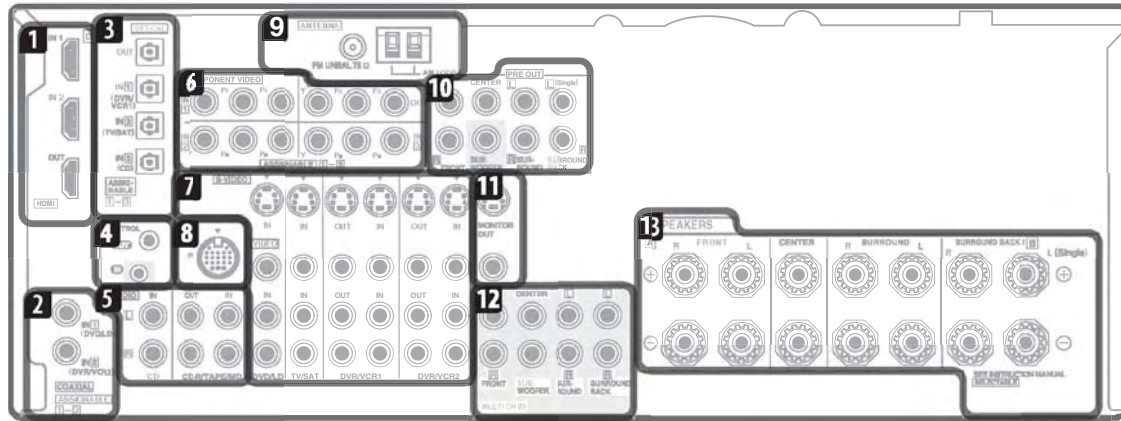

### Caution

- Before making or changing the connections, switch off the power and disconnect the power cord from the power outlet. Plugging in should be the final step.

#### 1 HDMI connectors (x3)

Two inputs and one output for high-quality audio/video connection to compatible HDMI devices.

#### 2 Coaxial digital audio inputs (x2)

Use for digital audio sources, including DVD players/recorders, digital satellite receivers, CD players, etc.

#### 3 Optical digital audio output/input(s) (x4)

Use the **OUT** jack for recording to a CD or MiniDisc recorder.

Use the **IN** jacks for digital audio sources, including DVD players/recorders, digital satellite receivers, CD players, etc.

#### 4 Control input/output

Use to connect other Pioneer components so that you can control all your equipment from a single IR remote sensor.

#### 5 Stereo analog audio source inputs/(outputs) (x3)

Use for connection to audio sources such as CD players, tape decks, turntables, etc.

#### 6 Component video connections (x4)

Use the inputs to connect any video source that has component video output, such as a DVD recorder. Use the output for connection to a monitor or TV.

#### 7 Audio/video source inputs/(outputs) (x6)

Use for connection to audio/visual sources, such as DVD players/recorders, VCRs, etc. Each set of inputs has jacks for composite video, S-video and stereo analog audio.

#### 8 iPod input terminal

Use to connect your Apple iPod as an audio source.

#### 9 AM and FM antenna terminals

Use to connect indoor or outdoor antennas for radio broadcasts.

#### 10 Multichannel pre-amplifier outputs

Use to connect separate amplifiers for front, center, surround, surround back and subwoofer channels.

#### 11 Composite and S-video monitor outputs

Use to connect monitors and TVs.

#### 12 Multichannel analog audio inputs

7.1 channel inputs for connection to a DVD player with multichannel analog outputs.

#### 13 Speaker terminals

Use for connection to the main front, center, surround and surround back speakers.

### Note

1 If the video signal does not appear on your TV or plasma display, try adjusting the resolution settings on your component or display. Note that some components (such as video game units) have resolutions that may not be converted. In this case, use an (analog) S-video or composite connection.

## ● Rear Panel (VSX-91TXH/VSX-9120TXH-K)

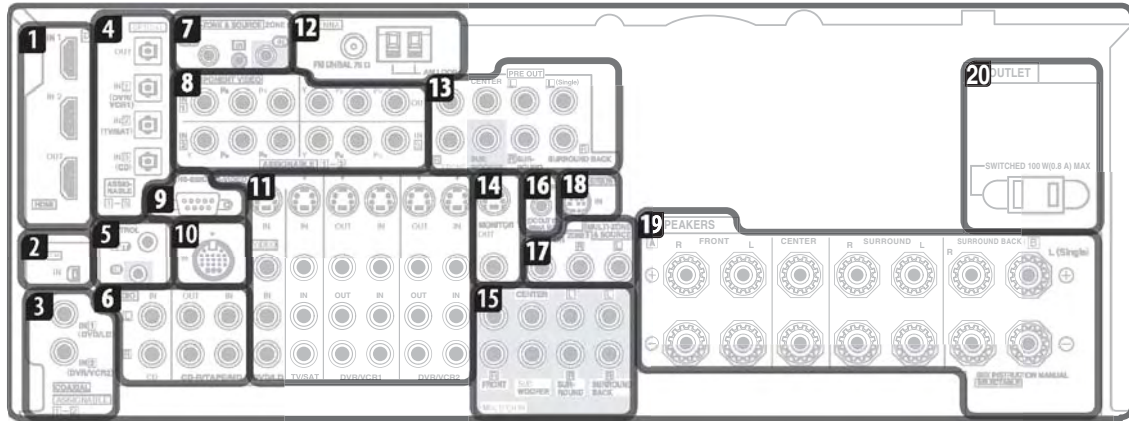

### ⚠ Caution

- Before making or changing the connections, switch off the power and disconnect the power cord from the power outlet. Plugging in should be the final step.

#### 1 HDMI connectors (x3)

Two inputs and one output for high-quality audio/video connection to compatible HDMI devices.

#### 2 XM Radio input

#### 3 Coaxial digital audio inputs (x2)

Use for digital audio sources, including DVD players/recorders, digital satellite receivers, CD players, etc.

#### 4 Optical digital audio output/input(s) (x4)

Use the **OUT** jack for recording to a CD or MiniDisc recorder.

Use the **IN** jacks for digital audio sources, including DVD players/recorders, digital satellite receivers, CD players, etc.

#### 5 Control input/output

Use to connect other Pioneer components so that you can control all your equipment from a single IR remote sensor.

#### 6 Stereo analog audio source inputs/outputs (x3)

Use for connection to audio sources such as CD players, tape decks, turntables, etc.

#### 7 Remote input (MULTI-ZONE and source)

Use for connection to an external remote control sensor for use in a MULTI-ZONE setup, for example.

#### 8 Component video connections (x4)

Use the inputs to connect any video source that has component video output, such as a DVD recorder. Use the output for connection to a monitor or TV.

#### 9 RS-232C connector

Use for connection to a PC for graphical output when using Advanced MCACC.

#### 10 iPod input terminal

Use to connect your Apple iPod as an audio source.

#### 11 Audio/video source inputs/outputs (x6)

Use for connection to audio/visual sources, such as DVD players/recorders, VCRs, etc. Each set of inputs has jacks for composite video, S-video and stereo analog audio.

#### 12 AM and FM antenna terminals

Use to connect indoor or outdoor antennas for radio broadcasts.

#### 13 Multichannel pre-amplifier outputs

Use to connect separate amplifiers for front, center, surround, surround back and subwoofer channels.

#### 14 Composite and S-video monitor outputs

Use to connect monitors and TVs.

#### 15 Multichannel analog audio inputs

7.1 channel inputs for connection to a DVD player with multichannel analog outputs.

#### 16 12 V trigger jack (total 50 mA max.)

Use to switch components in your system on and off according to the input function of the receiver.

#### 17 MULTI-ZONE and source outputs

Use to connect a second amplifier in a separate zone.

#### 18 SIRIUS Radio input

#### 19 Speaker terminals

Use for connection to the main front, center, surround and surround back speakers.

#### 20 Switched AC power outlet (100 W/0.8 A max.)

Use to power another component in the system. Power to the outlet switches on and off with the receiver.

### 📌 Note

1 If the video signal does not appear on your TV or plasma display, try adjusting the resolution settings on your component or display. Note that some components (such as video game units) have resolutions that may not be converted. In this case, use an (analog) S-video or composite connection.

## ● Display (VSX-LX50)

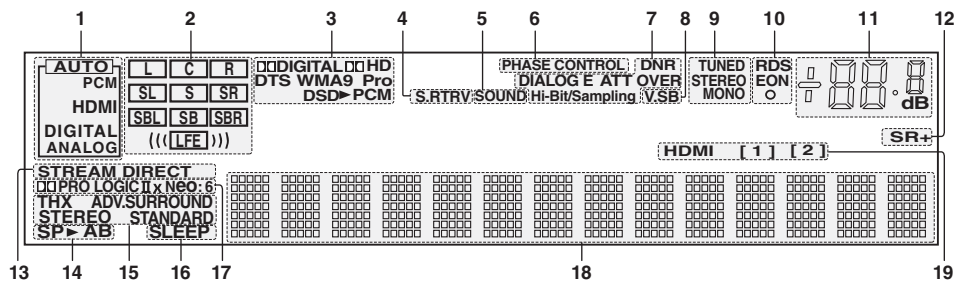

### 1 SIGNAL indicators

Light to indicate the currently selected input signal.

**AUTO** lights when the receiver is set to select the input signal automatically.

### 2 Program format indicators

These change according to which channels are active in digital sources.

**L** – Left front channel

**C** – Center channel

**R** – Right front channel

**SL** – Left surround channel

**S** – Surround channel (mono)

**SR** – Right surround channel

**SBL** – Left surround back channel

**SB** – Surround back channel (mono)

**SBR** – Right surround back channel

**LFE** – Low frequency effects channel (the ((( ))) indicators light when an LFE signal is being input)

### 3 Digital format indicators

Light when a signal encoded in the corresponding format is detected (**DSD**►**PCM** lights during the DSD (Direct Stream Digital) to PCM conversion with SACDs).

### 4 S.RTRV

Lights when the Sound Retriever is switched on.

### 5 SOUND

Lights when any of the Midnight, Loudness or tone controls feature is selected.

### 6 PHASE CONTROL

Lights when the Phase Control is switched on.

### 7 Sound processing indicators

Light according to the active AV parameter(s).

**OVER** lights to indicate that the level of an analog source is too high. **ATT** lights when you use the attenuator (**ANALOG ATT**) to reduce it.

### 8 V.SB

Lights during Virtual surround back processing.

### 9 TUNER indicators

**TUNED** – Lights when a broadcast is being received.

**STEREO** – Lights when a stereo FM broadcast is being received in auto stereo mode.

**MONO** – Lights when the mono mode is set using the **MPX** button.

### 10 EON / RDS indicators

**EON** – Lights when the EON mode is set (flashes during EON reception). The **o** indicator lights when the current station carries the EON service.

**RDS** – Lights when an RDS broadcast is received.

### 11 Master volume level

#### 12 SR+

Lights when the SR+ mode is switched on.

### 13 STREAM DIRECT

Lights when Direct / Pure Direct is selected.

### 14 Speaker indicators

Indicate the current speaker system, **A** and/or **B**.

### 15 Listening mode indicators

**THX** – Lights when a Home THX mode is selected.

**ADV. SURROUND** – Lights when an Advanced Surround mode has been selected.

**STEREO** – Lights when the stereo mode is selected.

**STANDARD** – Lights when a Standard Surround mode is switched on.

### 16 SLEEP

Lights when the receiver is in sleep mode.

### 17 Matrix decoding format indicators

□□**PRO LOGIC IIx** – This lights to indicate □□Pro Logic II / □□Pro Logic IIx decoding.

**Neo:6** – When one of the Neo:6 modes of the receiver is on, this lights to indicate Neo:6 processing.

### 18 Character display

Displays various system information.

### 19 HDMI connection indicators

Light to indicate the HDMI input currently selected.

## ● Display (VSX-91TXH/VSX-9120TXH-K)

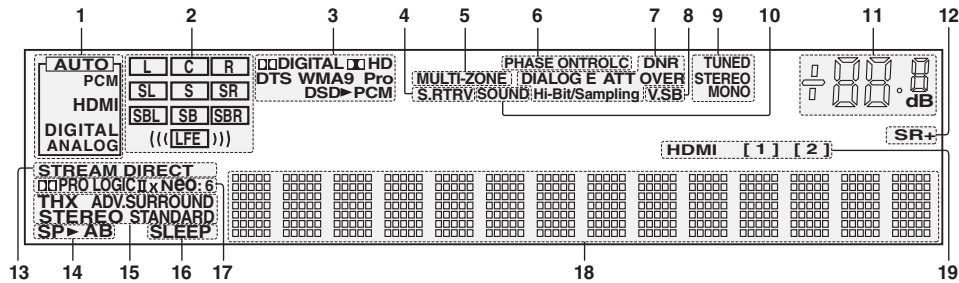

### 1 SIGNAL indicators

Light to indicate the currently selected input signal.

**AUTO** lights when the receiver is set to select the input signal automatically.

### 2 Program format indicators

These change according to which channels are active in digital sources.

**L** – Left front channel

**C** – Center channel

**R** – Right front channel

**SL** – Left surround channel

**S** – Surround channel (mono)

**SR** – Right surround channel

**SBL** – Left surround back channel

**SB** – Surround back channel (mono)

**SBR** – Right surround back channel

**LFE** – Low frequency effects channel (the ((( ))) indicators light when an LFE signal is being input)

### 3 Digital format indicators

Light when a signal encoded in the corresponding format is detected (**DSD▶PCM** lights during the DSD (Direct Stream Digital) to PCM conversion with SACDs).

### 4 S.RTRV

Lights when the Sound Retriever is switched on.

### 5 MULTI-ZONE

Lights when the MULTI-ZONE feature is active.

### 6 PHASE CONTROL

Lights when the Phase Control is switched on.

### 7 Sound processing indicators

Light according to the active AV parameter(s).

**OVER** lights to indicate that the level of an analog source is too high. **ATT** lights when you use the attenuator (**ANALOG ATT**) to reduce it.

### 8 V.SB

Lights during Virtual surround back processing.

### 9 TUNER indicators

**TUNED** – Lights when a broadcast is being received.

**STEREO** – Lights when a stereo FM broadcast is being received in auto stereo mode.

**MONO** – Lights when the mono mode is set using the **MPX** button.

### 10 SOUND

Lights when any of the Midnight, Loudness or tone controls feature is selected.

### 11 Master volume level

### 12 SR+

Lights when the SR+ mode is switched on.

### 13 STREAM DIRECT

Lights when Direct / Pure Direct is selected.

### 14 Speaker indicators

Indicate the current speaker system, **A** and/or **B**.

### 15 Listening mode indicators

**THX** – Lights when a Home THX mode is selected.

**ADV.SURROUND** – Lights when an Advanced Surround mode has been selected.

**STEREO** – Lights when the stereo mode is selected.

**STANDARD** – Lights when a Standard Surround mode is switched on.

### 16 SLEEP

Lights when the receiver is in sleep mode.

### 17 Matrix decoding format indicators

□□**PRO LOGIC IIx** – This lights to indicate □□ Pro Logic II / □□ Pro Logic IIx decoding.

**Neo:6** – When one of the Neo:6 modes of the receiver is on, this lights to indicate Neo:6 processing.

### 18 Character display

Displays various system information.

### 19 HDMI connection indicators

Light to indicate the HDMI input currently selected.

## ● Remote Control (VSX-LX50)

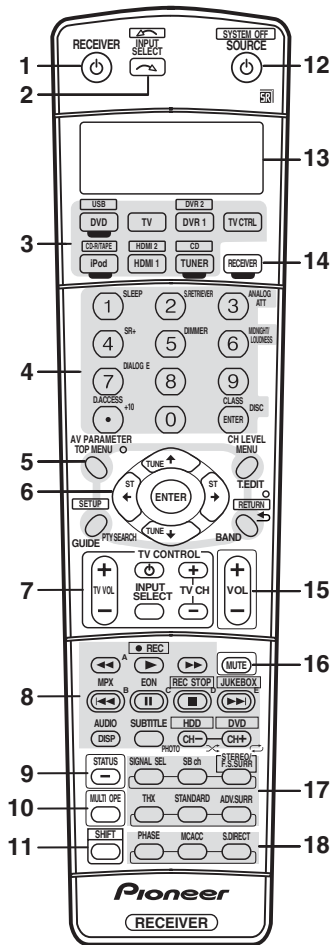

The remote has been conveniently color-coded according to component control using the following system (press the corresponding input source button to access):

- **Green** – Receiver controls (see below)
- **Red** – DVD controls
- **Blue** – Tuner controls
- **Yellow** – iPod controls
- **White** – Other controls

### 1 RECEIVER

This switches between standby and on for this receiver.

### 2 INPUT SELECT

Use to select the input source (use **SHIFT** for **INPUT SELECT** ).

### 3 Input source buttons

Press to select control of other components.

### 4 Number buttons and other receiver/component controls

Use the number buttons to directly select a radio frequency or the tracks on a CD, DVD, etc.

**DISC (ENTER)** can be used to enter commands for TV or DTV, and also to select a disc in a multi-CD player.

Press **RECEIVER** first to access:

**SLEEP** – Use to put the receiver in sleep mode and select the amount of time before sleep.

**S.RETRIEVER** – Press to restore CD quality sound to compressed audio sources.

**ANALOG ATT** – Attenuates (lowers) the level of an analog input signal to prevent distortion.

**SR+** – Switches the SR+ mode on/off.

**DIMMER** – Dims or brightens the display.

**MIDNIGHT/LOUDNESS** – Use Midnight when listening to movie soundtracks at low volume. Use Loudness to boost the bass and treble at low volume.

**DIALOG E** – Use to make dialog stand out when watching TV or a movie.

Press **TUNER** first to access:

**D.ACCESS** – After pressing, you can access a radio station directly using the number buttons.

**CLASS** – Switches between the three banks (classes) of radio station presets.

### 5 Tuner/component control buttons/SETUP

These button controls can be accessed after you have selected the corresponding input source button (**DVD**, **DVR1**, **TV**, etc.). The **BAND**, **T.EDIT** and **PTY SEARCH** tuner controls are explained. Press **RECEIVER** first to access the following controls:

**AV PARAMETER** – Use to access the AV options.

**SETUP** – Use to access the System Setup menu .

**CH LEVEL** – Press repeatedly to select a channel, then use **←/→** to adjust the level.

**RETURN** – Press to confirm and exit the current menu screen (also use to return to the previous menu with DVDs or to select closed captioning with DTV).

### 6 **←→↓↑ (TUNE/ST) /ENTER**

Use the arrow buttons when setting up your surround sound system and the AV options.

Also used to control DVD menus/options and for deck 1 of a double cassette deck player. Use the **TUNE ↑/↓** buttons to find radio frequencies and use **ST ←/→** to find preset stations.

## 7 TV CONTROL buttons

These buttons are dedicated to control the TV assigned to the **TV CTRL** button. Thus if you only have one TV to hook up to this system assign it to the **TV CTRL** input source button. If you have two TVs, assign the main TV to the **TV CTRL** button.



**TV**  – Use to turn on/off the power of the TV.

**TV VOL +/-** – Use to adjust the volume on your TV.

**INPUT SELECT** – Use to select the TV input signal.

**TV CH +/-** – Use to select channels.

## 8 Component control buttons

The main buttons (, , etc.) are used to control a component after you have selected it using the input source buttons.

The controls above these buttons can be accessed after you have selected the corresponding input source button (for example **DVD**, **DVR1** or **TV**). The following controls can be accessed when listening to the built-in tuner:

**MPX** – Switches between stereo and mono reception of FM broadcasts. If the signal is weak then switching to mono will improve the sound quality.

**DISP** – Switches between named station presets and radio frequencies. Also used to display RDS information.

**EON** – Use to search for programs that are broadcasting traffic or news information.

## 9 STATUS

Press to check selected receiver settings.

## 10 MULTI OPE

Use this button to perform multi operations.

## 11 SHIFT

Press to access the controls outlined in white boxes (for example, **INPUT SELECT** ) , or to display the currently selected input source in the remote control LCD.

## 12 SOURCE

Press to turn on/off other components connected to the receiver.

## 13 Character display (LCD)

This display shows information when transmitting control signals.

The following commands are shown when you're setting the remote to control other components.

**SETUP** – Indicates the setup mode, from which you choose the options below.

**PRESET** – See Selecting preset codes directly

**LEARNING** – See Programming signals from other remote controls.

**MULTI OP** – See Multi Operation and System Off.

**SYS OFF** – See Multi Operation and System Off.

**DIRECT F** – See Direct function.

**RENAME** – See Renaming input source names.

**ERASE** – See Erasing one of the remote control button settings.

**RESET** – See Resetting the remote control presets.

**READ ID** – See Confirming preset codes.

## 14 RECEIVER

Switches the remote to control the receiver (used to select the green commands above the number buttons (**ANALOG ATT**, etc.)). Also use this button to set up surround sound.

## 15 VOL +/-

Use to set the listening volume.

## 16 MUTE

Mutes the sound or restores the sound if it has been muted (adjusting the volume also restores the sound).

## 17 Receiver controls

**SIGNAL SEL** – Use to select an input signal.

**SB ch** – Use to select the surround/virtual back channel mode.

**STEREO/F.S.SURR** – Switches between the stereo playback mode and the Front Stage Surround Advance mode.

**THX** – Press to select a Home THX listening mode.

**STANDARD** – Press for Standard decoding and to switch between the various  Pro Logic IIx and Neo:6 options.

**ADV.SURR** – Use to switch between the various surround modes.

## 18 PHASE– Press to switch on/off Phase Control.

**MCACC** – Press to switch between MCACC presets.

**S.DIRECT** – Press to select the Auto Surround mode or the Stream Direct mode.

Stream Direct playback bypasses the tone controls and any other signal processing for the most accurate reproduction of a source.

## ● Remote Control (VSX-91TXH/VSX-9120TXH-K)

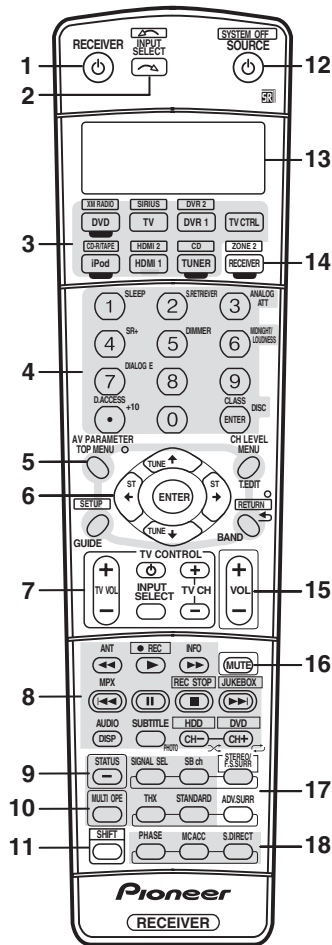

The remote has been conveniently color-coded according to component control using the following system (press the corresponding input source button to access):

- **Green** – Receiver controls (see below)
- **Red** – DVD controls
- **Blue** – Tuner, XM and SIRIUS Radio controls
- **Yellow** – iPod controls
- **White** – Other controls

### 1 RECEIVER

This switches between standby and on for this receiver.

### 2 INPUT SELECT

Use to select the input source (use **SHIFT** for **INPUT SELECT** ).

### 3 Input source buttons

Press to select control of other components.

### 4 Number buttons and other receiver/component controls

Use the number buttons to directly select a radio frequency or the tracks on a CD, DVD, etc.

**DISC (ENTER)** can be used to enter commands for TV or DTV, and also to select a disc in a multi-CD player.

Press **RECEIVER** first to access:

**SLEEP** – Use to put the receiver in sleep mode and select the amount of time before sleep.

**S.RETRIEVER** – Press to restore CD quality sound to compressed audio sources.

**ANALOG ATT** – Attenuates (lowers) the level of an analog input signal to prevent distortion.

**SR+** – Switches the SR+ mode on/off.

**DIMMER** – Dims or brightens the display.

**MIDNIGHT/LOUDNESS** – Use Midnight when listening to movie soundtracks at low volume. Use Loudness to boost the bass and treble at low volume.

**DIALOG E** – Use to make dialog stand out when watching TV or a movie.

Press **TUNER** first to access:

**D.ACCESS** – After pressing, you can access a radio station directly using the number buttons.

**CLASS** – Switches between the three banks (classes) of radio station presets.

### 5 Tuner/component control buttons/SETUP

These button controls can be accessed after you have selected the corresponding input source button (**DVD**, **DVR1**, **TV**, etc.). The **BAND** and **T.EDIT** tuner controls are explained. Press **RECEIVER** first to access the following controls:

**AV PARAMETER** – Use to access the AV options.

**SETUP** – Use to access the System Setup menu.

**CH LEVEL** – Press repeatedly to select a channel, then use **←/→** to adjust the level.

**RETURN** – Press to confirm and exit the current menu screen (also use to return to the previous menu with DVDs or to select closed captioning with DTV).

### 6 **←→↓↑ (TUNE/ST) /ENTER**

Use the arrow buttons when setting up your surround sound system and the AV options.

Also used to control DVD menus/options and for deck 1 of a double cassette deck player. Use the **TUNE↑/↓** buttons to find radio frequencies and use **ST←/→** to find preset stations.

## 7 TV CONTROL buttons

These buttons are dedicated to control the TV assigned to the **TV CTRL** button. Thus if you only have one TV to hook up to this system assign it to the **TV CTRL** input source button. If you have two TVs, assign the main TV to the **TV CTRL** button.



**TV**  – Use to turn on/off the power of the TV.

**TV VOL +/-** – Use to adjust the volume on your TV.

**INPUT SELECT** – Use to select the TV input signal.

**TV CH +/-** – Use to select channels.

## 8 Component control buttons

The main buttons (, , etc.) are used to control a component after you have selected it using the input source buttons.

The controls above these buttons can be accessed after you have selected the corresponding input source button (for example **DVD**, **DVR1** or **TV**). The following controls can be accessed when listening to the built-in tuner:

**MPX** – Switches between stereo and mono reception of FM broadcasts. If the signal is weak then switching to mono will improve the sound quality.

**DISP** – Switches between named station presets and radio frequencies.

## 9 STATUS

Press to check selected receiver settings.

## 10 MULTI OPE

Use this button to perform multi operations.

## 11 SHIFT

Press to access the controls outlined in white boxes (for example, **INPUT SELECT** ) or to display the currently selected input source in the remote control LCD.

## 12 SOURCE

Press to turn on/off other components connected to the receiver.

## 13 Character display (LCD)

This display shows information when transmitting control signals.

The following commands are shown when you're setting the remote to control other components:

**SETUP** – Indicates the setup mode, from which you choose the options below.

**PRESET** – See Selecting preset codes directly.

**LEARNING** – See Programming signals from other remote controls.

**MULTI OP** – See Multi Operation and System Off.

**SYS OFF** – See Multi Operation and System Off.

**DIRECT F** – See Direct function.

**RENAME** – See Renaming input source names.

**ERASE** – See Erasing one of the remote control button settings.

**RESET** – See Resetting the remote control presets.

**READ ID** – See Confirming preset codes.

## 14 RECEIVER

Switches the remote to control the receiver (used to select the green commands above the number buttons (**ANALOG ATT**, etc.)). Also use this button to set up surround sound. With **SHIFT**, this selects the MULTI-ZONE control.

## 15 VOL +/-

Use to set the listening volume.

## 16 MUTE

Mutes the sound or restores the sound if it has been muted (adjusting the volume also restores the sound).

## 17 Receiver controls

**SIGNAL SEL** – Use to select an input signal.

**SB ch** – Use to select the surround/virtual back channel mode.

**STEREO/F.S.SURR** – Switches between the stereo playback mode and the Front Stage Surround Advance mode.

**THX** – Press to select a Home THX listening mode.

**STANDARD** – Press for Standard decoding and to switch between the various  Pro Logic IIx and Neo:6 options.

**ADV.SURR** – Use to switch between the various surround modes.

## 18 PHASE – Press to switch on/off Phase Control.

**MCACC** – Press to switch between MCACC presets.

**S.DIRECT** – Press to select the Auto Surround mode or the Stream Direct mode.

Stream Direct playback bypasses the tone controls and any other signal processing for the most accurate reproduction of a source.

# 3. BASIC ITEMS FOR SERVICE

## 3.1 CHECK POINTS AFTER SERVICING

To keep the product quality after servicing, confirm recommended check points shown below.

No.	Procedure	Check points
1	Confirm whether the customer complain has been solved. If the customer complain occurs with the particular source, such as Dolby Digital, DTS, AAC, DVD-A and HDMI, input it for the operation check.	The customer complain must not be reappeared. Video, Audio and operations must be normal.
2	Check the analog audio playback. (Make the analog connections with a DVD player.)	Each channel audio and operations must be normal.
3	Check the digital audio playback. (Make the digital connections with a DVD player.)	Each channel audio and operations must be normal.
4	Check surround playback. (Select Surround mode and check the multichannel operations via the DSP circuit.)	Each channel audio and operations must be normal.
5	Check the video outputs. (Connect with a DVD player.)	Video and operations must be normal.
6	Check the sound from headphone output.	Sound must be normal, without noise.
7	Check the appearance of the product.	No scratches or dirt on its appearance after receiving it for service.

See the table below for the items to be checked regarding video and audio:

Items to be checked regarding video	Item to be checked regarding audio
Block noise	Distortion
Horizontal noise	Noise
Dot noise	Volume too low
Disturbed image (video jumpiness)	Volume too high
Too dark	Volume fluctuating
Too bright	Sound interrupted
Mottled color	

### 3.2 PCB LOCATIONS

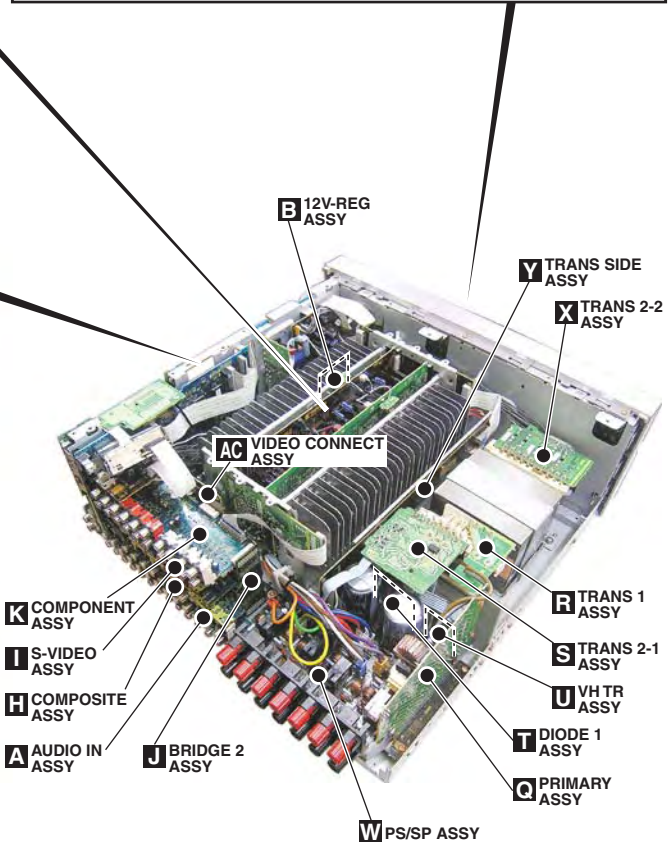
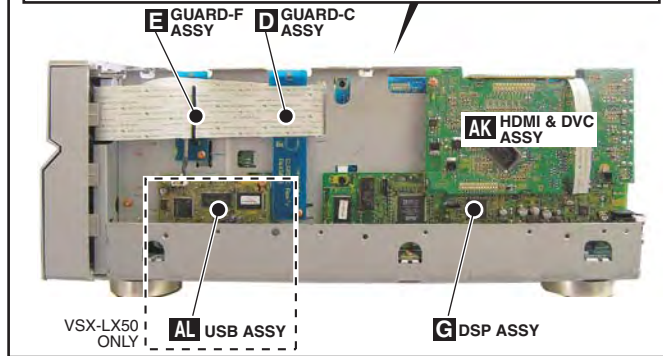
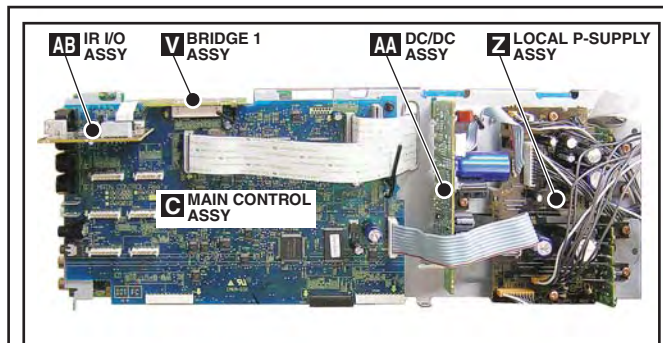
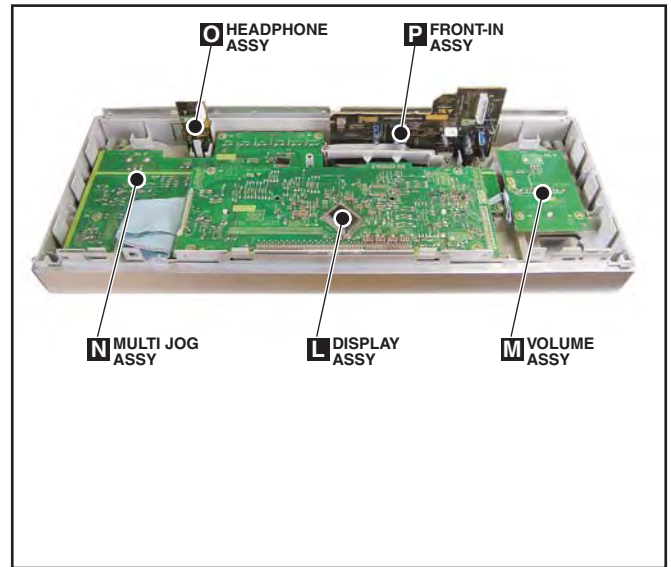
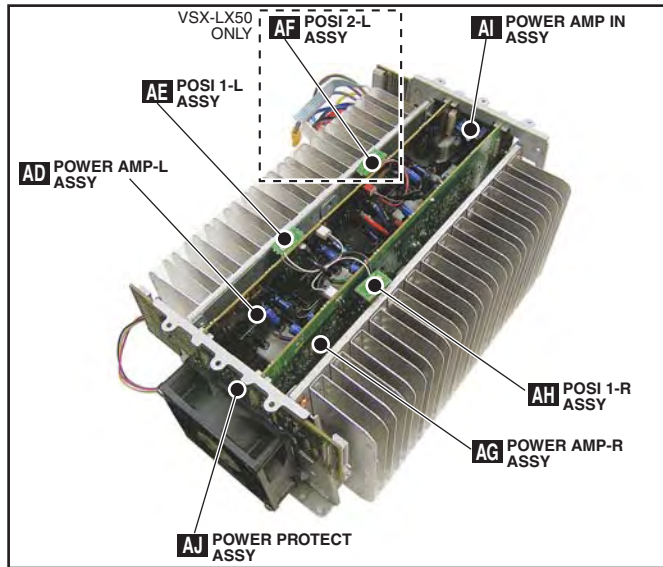

NOTES: ● Parts marked by "NSP" are generally unavailable because they are not in our Master Spare Parts List.

● The  $\Delta$  mark found on some component parts indicates the importance of the safety factor of the part. Therefore, when replacing, be sure to use parts of identical designation.

◆ LIST OF ASSEMBLIES

Mark	Symbol and Description	VSX-LX50 /HYXJ5	VSX-91TXH /KUXJ/CA	VSX-9120TXH-K /KUXJ
NSP	1..MAIN ASSY	AWK7975	AWK7974	AWK7974
	2..MAIN CONTROL ASSY	AWX8817	AWX8816	AWX8816
	2..AUDIO IN ASSY	AWX8821	AWX8820	AWX8820
	2..12V-REG ASSY	AWX8824	AWX8824	AWX8824
	2..GUARD-C ASSY	AWX8826	AWX8826	AWX8826
	2..GUARD-F ASSY	AWX8825	AWX8825	AWX8825
	1..DSP ASSY	AWX8814	AWX8813	AWX8813
NSP	1..VIDEO ASSY	AWK7984	AWK7983	AWK7983
	2..COMPOSITE ASSY	AWX8842	AWX8841	AWX8841
	2..S-VIDEO ASSY	AWX8845	AWX8844	AWX8844
	2..COMPONENT ASSY	AWX8848	AWX8847	AWX8847
	2..BRIDGE 2 ASSY	AWX8850	AWX8850	AWX8850
NSP	1..COMPLEX ASSY	AWK8015	AWK8014	AWK8014
	2..PRIMARY ASSY	AWX9035	AWX9034	AWX9034
	2..TRANS 1 ASSY	AWX9038	AWX9038	AWX9038
	2..DISPLAY ASSY	AWX8874	AWX8873	AWX8873
	2..VOLUME ASSY	AWX9111	AWX9044	AWX9044
	2..MULTI JOG ASSY	AWX8880	AWX8879	AWX8879
	2..FRONT-IN ASSY	AWX8955	AWX8954	AWX8954
2..HEADPHONE ASSY	AWX9049	AWX9049	AWX9049	
NSP	1..SECONDARY ASSY	AWK7911	AWK7910	AWK7910
	2..PS/SP ASSY	AWX9107	AWX9052	AWX9052
	2..TRANS SIDE ASSY	AWX9056	AWX9056	AWX9056
	2..TRANS 2-1 ASSY	AWX9059	AWX9058	AWX9058
	2..DIODE 1 ASSY	AWX9060	AWX9060	AWX9060
	2..VH TR ASSY	AWX9061	AWX9061	AWX9061
	2..TRANS 2-2 ASSY	AWX9062	AWX9062	AWX9062
	2..LOCAL P-SUPPLY ASSY	AWX9064	AWX9063	AWX9063
	2..IR I/O ASSY	AWX9067	AWX9066	AWX9066
	2..VIDEO CONNECT ASSY	AWX9069	AWX9069	AWX9069
	2..DC/DC ASSY	AWX9015	AWX9015	AWX9015
2..BRIDGE 1 ASSY	AWX9078	AWX9078	AWX9078	
NSP	1..POWER AMP ASSY	AWK7920	AWK7919	AWK7919
	2..POWER AMP-L ASSY	AWX9072	AWX9071	AWX9071
	2..POWER AMP-R ASSY	AWX9073	AWX9106	AWX9106
	2..POWER AMP IN ASSY	AWX9075	AWX9075	AWX9075
	2..POWER PROTECT ASSY	AWX9077	AWX9076	AWX9076
	2..POSI 1-L ASSY	AWX9081	AWX9080	AWX9080
	2..POSI 2-L ASSY	AWX9082	Not used	Not used
	2..POSI 1-R ASSY	AWX9084	AWX9083	AWX9083
	1..HDMI & DVC ASSY	AWQ7040	AWQ7040	AWQ7040
	1..USB ASSY	AWX8866	Not used	Not used
	1..FM/AM TUNER UNIT	AXX7248	AXX7250	AXX7250

### 3.3 JIGS LIST

#### ■ Jigs list

Name	Jig No.	Remarks
11P board to board extension jig cable	GGD1482	Diagonosis
13P board to board extension jig cable	GGD1483	Diagonosis
15P board to board extension jig cable	GGD1484	Diagonosis
21P board to board extension jig cable	GGD1485	Diagonosis
RS-232C I/F jig	GGF1348	Update the Flash ROMS
7-pin FFC	VDA1681	Update the Flash ROMS

#### ■ CLEANING



Before shipping out the product, be sure to clean the following positions by using the prescribed cleaning tools:

Position to be cleaned	Cleaning tools
Fans	Cleaning paper : GED-008

# 4. BLOCK DIAGRAM

## 4.1 OVERALL WIRING DIAGRAM

1

2

3

4

The  $\Delta$  mark found on some component parts indicates the importance of the safety factor of the part. Therefore, when replacing, be sure to use parts of identical designation.

**M** VOLUME ASSY  
(VSX-LX50 : AWX9111)  
(VSX-91TXH, VSX-9120TXH : AWX9044)

**L** DISPLAY ASSY  
(VSX-LX50 : AWX8874)  
(VSX-91TXH, VSX-9120TXH : AWX8873)

**N** MULTI JOG ASSY  
(VSX-LX50 : AWX8880)  
(VSX-91TXH, VSX-9120TXH : AWX8879)

A  
B  
C  
D  
E  
F

**P** FRONT-IN ASSY  
(VSX-LX50 : AWX8955)  
(VSX-91TXH, VSX-9120TXH : AWX8954)

**AH** POSI 1-R ASSY  
(VSX-LX50 : AWX9084)  
(VSX-91TXH, VSX-9120TXH : AWX9083)

**1** 1902 AXM7029 FRONT FAN  
VSX-LX50 ONLY

**Z** LOCAL P-SUPPLY ASSY  
(VSX-LX50 : AWX9064)  
(VSX-91TXH, VSX-9120TXH : AWX9063)

**AJ** POWER PROTECT ASSY  
(VSX-LX50 : AWX9077)  
(VSX-91TXH, VSX-9120TXH : AWX9076)

**AA** DC/DC ASSY  
(AWX9015)

**B** 12V-REG ASSY  
(AWX8824)

**AG** POWER AMP-R ASSY  
(VSX-LX50 : AWX9073)  
(VSX-91TXH, VSX-9120TXH : AWX9106)

**AD** POWER AMP-L ASSY  
(VSX-LX50 : AWX9072)  
(VSX-91TXH, VSX-9120TXH : AWX9071)

**AL** USB ASSY  
(AWX8866)  
VSX-LX50 ONLY

**AI** POWER AMP IN ASSY  
(AWX9075)

**A (A 1/2, A 2/2)** AUDIO IN ASSY  
(VSX-LX50 : AWX8821)  
(VSX-91TXH, VSX-9120TXH : AWX8820)

**C (C 1/3- C 3/3)** MAIN CONTROL ASSY  
(VSX-LX50 : AWX8817)  
(VSX-91TXH, VSX-9120TXH : AWX8816)

**AB** IR I/O ASSY  
(VSX-LX50 : AWX9067)  
(VSX-91TXH, VSX-9120TXH : AWX9066)

**AC** VIDEO CONNECT ASSY  
(AWX9069)

**G (G 1/4- G 4/4)** DSP ASSY  
(VSX-LX50 : AWX8814)  
(VSX-91TXH, VSX-9120TXH : AWX8813)

**AK (AK 1/2, AK 2/2)** HDMI & DVC ASSY (AWQ7040)

**V** BRIDGE 1 ASSY  
(AWX9078)

**K** COMPONENT ASSY  
(VSX-LX50 : AWX8848)  
(VSX-91TXH, VSX-9120TXH : AWX8847)

**I** S-VIDEO ASSY  
(VSX-LX50 : AWX8845)  
(VSX-91TXH, VSX-9120TXH : AWX8844)

**H** COMPOSITE ASSY  
(VSX-LX50 : AWX8842)  
(VSX-91TXH, VSX-9120TXH : AWX8841)

**J** BRIDGE 2 ASSY  
(AWX8850)

VSX-LX50

1

2

3

4

**O** HEADPHONE ASSY (AWX9049)

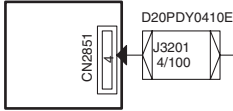

- When ordering service parts, be sure to refer to "EXPLODED VIEWS and PARTS LIST" or "PCB PARTS LIST".
- The ⚠ mark found on some component parts indicates the importance of the safety factor of the part. Therefore, when replacing, be sure to use parts of identical designation.
-  : The power supply is shown with the marked box.

**POS1 1-L ASSY**  
(VSX-LX50 : AWX9081)  
(VSX-91TXH, VSX-9120TXH : AWX9080)

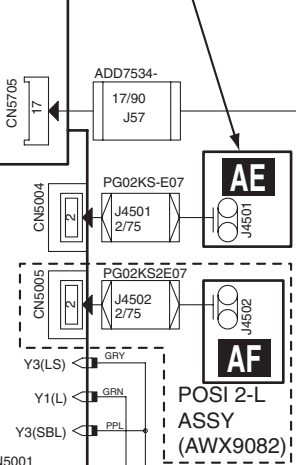

**TRANS SIDE ASSY** (AWX9056)



**X** TRANS 2-2 ASSY (AWX9062)

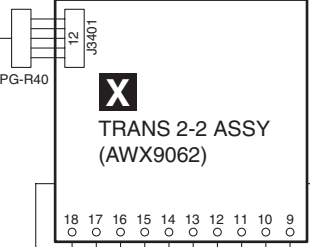

**MAIN TRANS** T1501

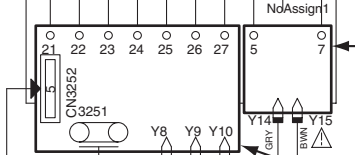

















**R** TRANS 1 ASSY (AWX9038)

**S** TRANS 2-1 ASSY (VSX-LX50 : AWX9059)  
(VSX-91TXH, VSX-9120TXH : AWX9058)

**T** DIODE 1 ASSY (AWX9060)

**U** VH TR ASSY (AWX9061)

-  BOARD IN
-  PF\*\*PG-\*\*\* CABLE WIRE
-  1.25mm FFC (\*;1.00mm FFC)
-  2.0mm FLAT CABLE (\*;1.5mm FLAT CABLE)
-  1.25mm FFC CONNECTOR(L) (\*;1.00mm FFC CONNECTOR)
-  1.25mm FFC CONNECTOR(I) (\*;1.00mm FFC CONNECTOR)
-  2.0mm CABLE HOLDER (\*;1.5mm CABLE HOLDER)
-  2.0mm WIRE TRAP
-  B\*B-PH-K-S PH CONNECTOR
-  ANOTHER TYPE CODE SOCKET
-  ANOTHER TYPE CODE CONNECTOR
-  XKP%-A 1.25mm BOARD TO BOARD
-  XKP%-A 1.25mm BOARD TO BOARD
-  KP250NA 2.5mm BOARD TO BOARD
-  2.5mm BOARD TO BOARD
-  ANOTHER TYPE BtoB SOCKET
-  ANOTHER TYPE BtoB CONNECTOR

**FM/AM TUNER UNIT** (VSX-LX50 : AXX7248)  
(VSX-91TXH, VSX-9120TXH : AXX7250)

No Schematic Diagram

**PS/SP ASSY** (VSX-LX50 : AWX9107)  
(VSX-91TXH, VSX-9120TXH : AWX9052)

**W**

**Q** PRIMARY ASSY (VSX-LX50 : AWX9035)  
(VSX-91TXH, VSX-9120TXH : AWX9034)

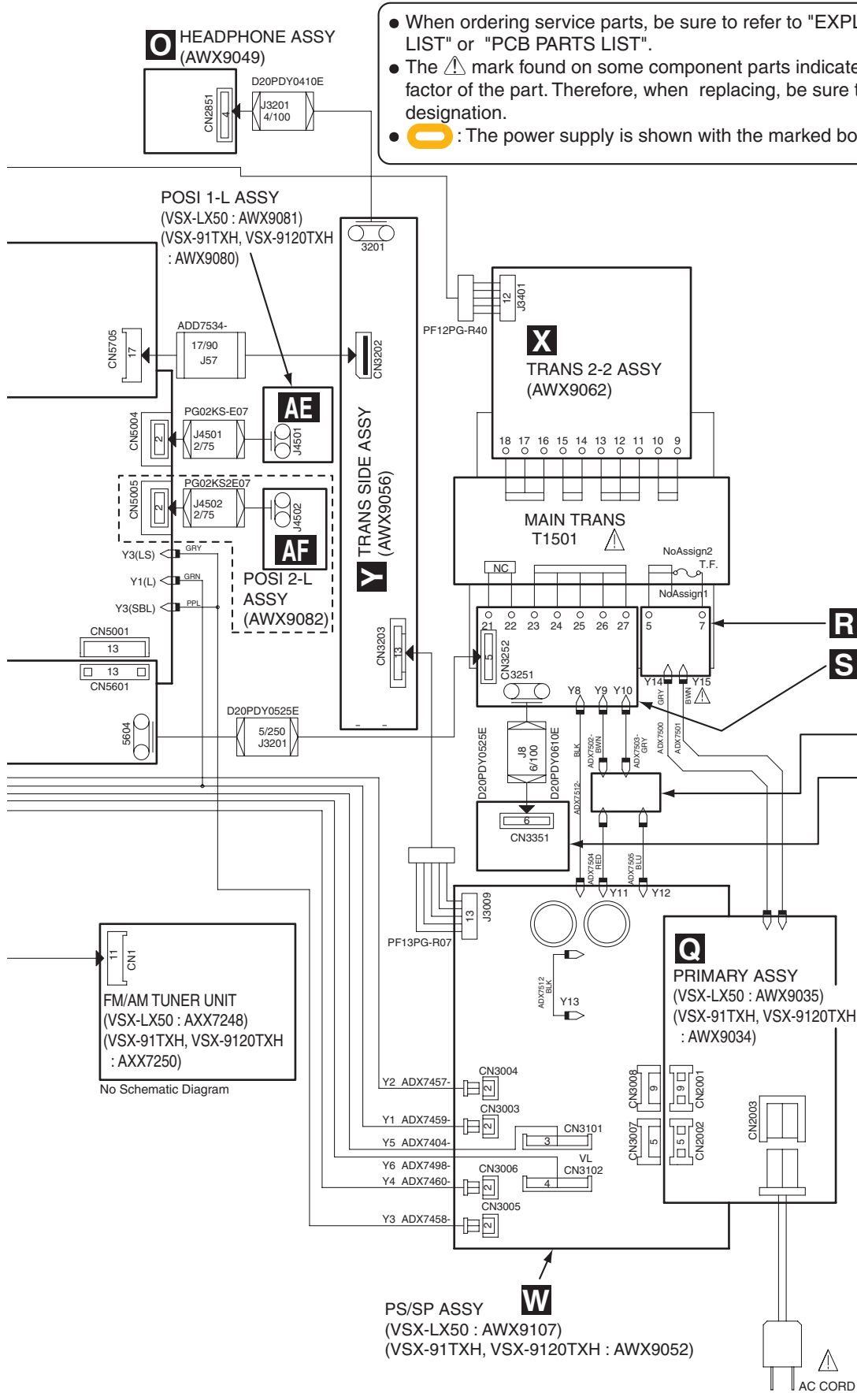

# 4.2 BLOCK DIAGRAM for AUDIO BLOCK

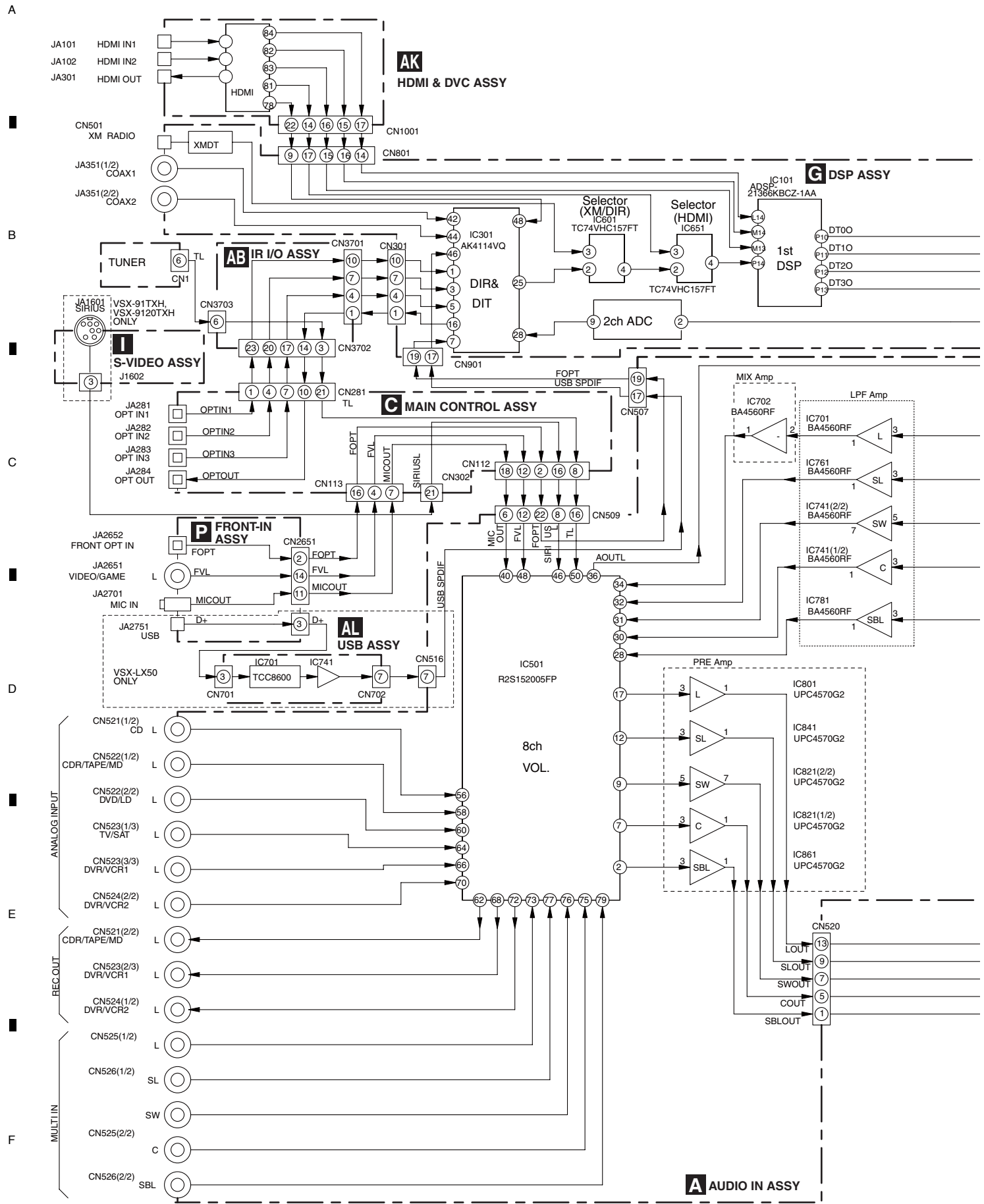

A  
B  
C  
D  
E  
F

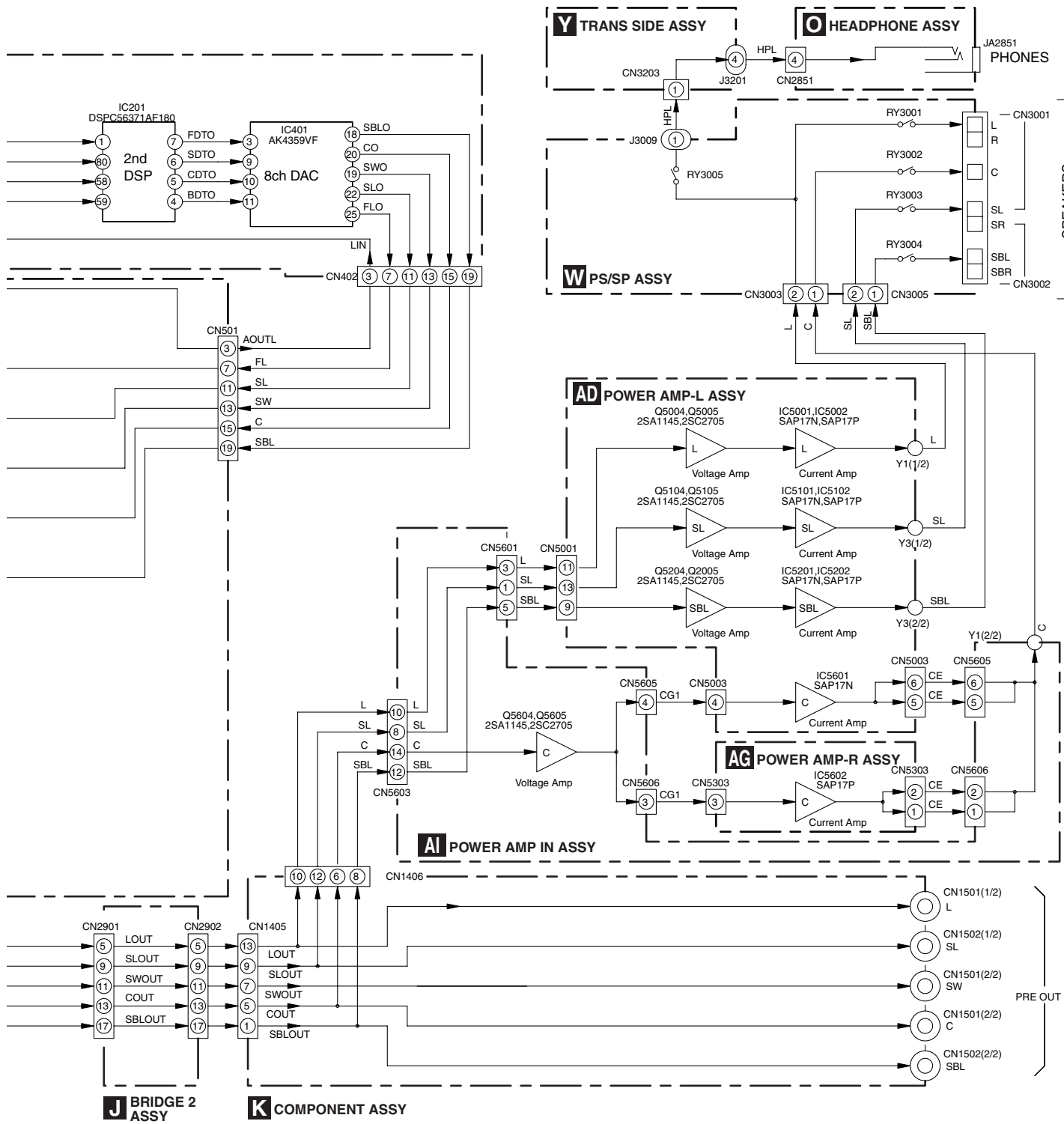

# 4.3 BLOCK DIAGRAM for VIDEO BLOCK

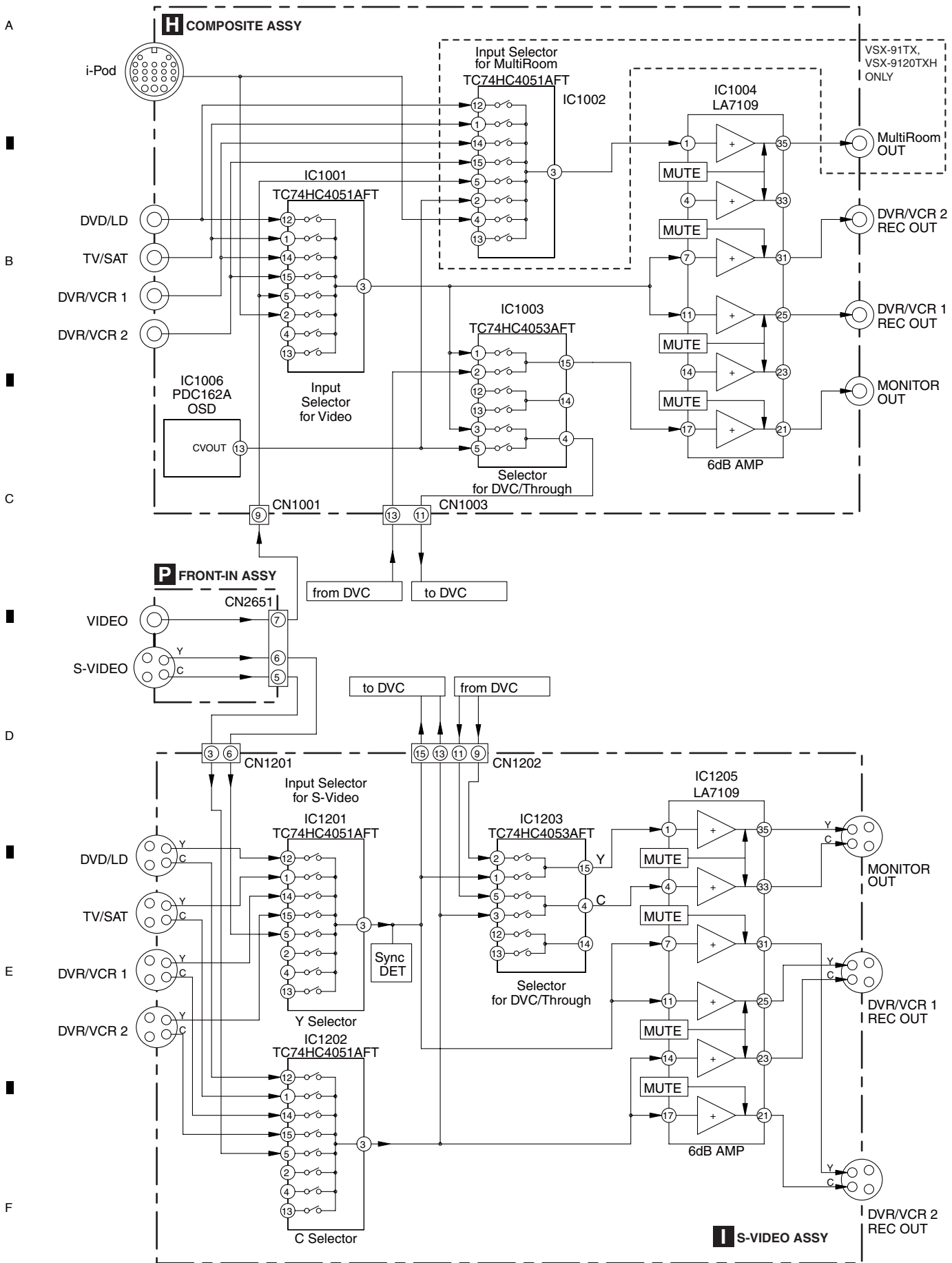

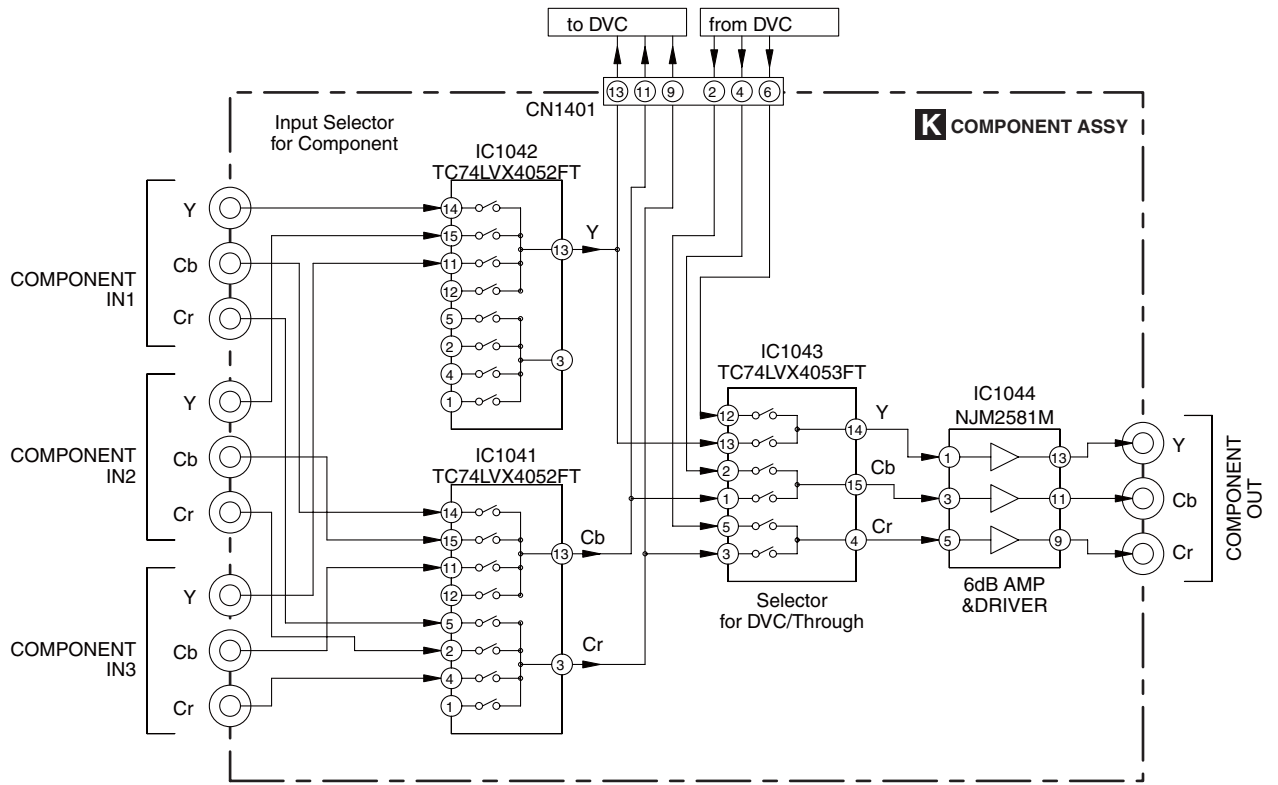

A  
B  
C  
D  
E  
F

# 5. DIAGNOSIS

## 5.1 DIAGNOSIS FLOWCHART

### 5.1.1 DSP TROUBLESHOOTING

#### ■ Simplified diagnosis

Herein is described how to easily diagnose a defective part in the DSP Assy, only with operations of the main unit.

Errors in DSP Assembly (Areas simply and roughly predictable by machine operation only)

- Sound abnormality in phase control

If sound abnormality does not occur in the phase-control OFF state but occurs in the phase-control ON state, it is most likely that a failure has occurred in SPAM (IC107), LATCH (IC103) or DECODER IC (IC105) in the 1st DSP Block.

- No sound at analog signal input

If sound abnormality does not occur with a digital signal input (COAX, OPT) but occurs only with an analog signal input, it is most likely that a failure has occurred in the AD converter (IC481).

#### ■ Troubleshooting

- It is assumed that there is no loose connection or damage in the LCRs.
- ■■■■ : KUXJ and KUXJ/CA types only

#### Step 0: Preliminary confirmation

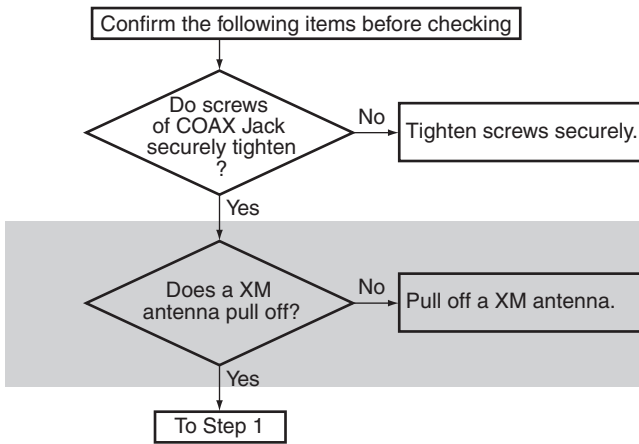

#### Step 2: Power supply

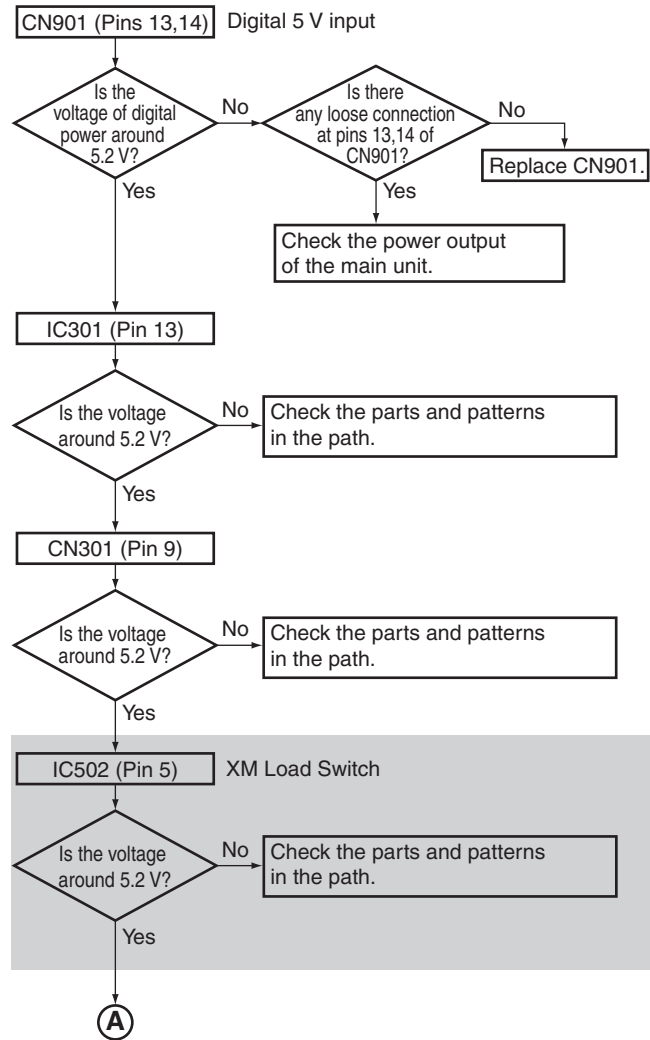

#### Step 1: Connections

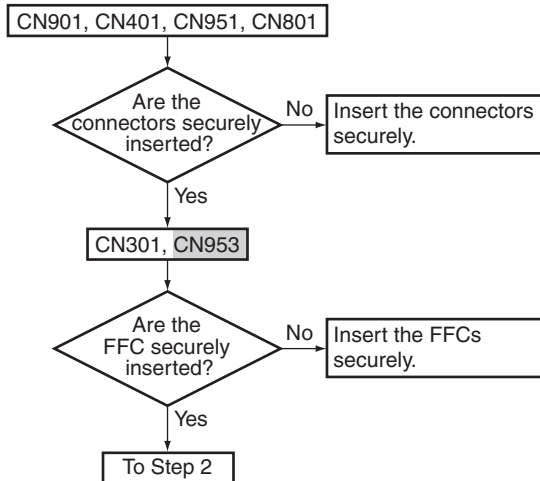

• [Grey Box] : KUXJ and KUXJ/CA types only

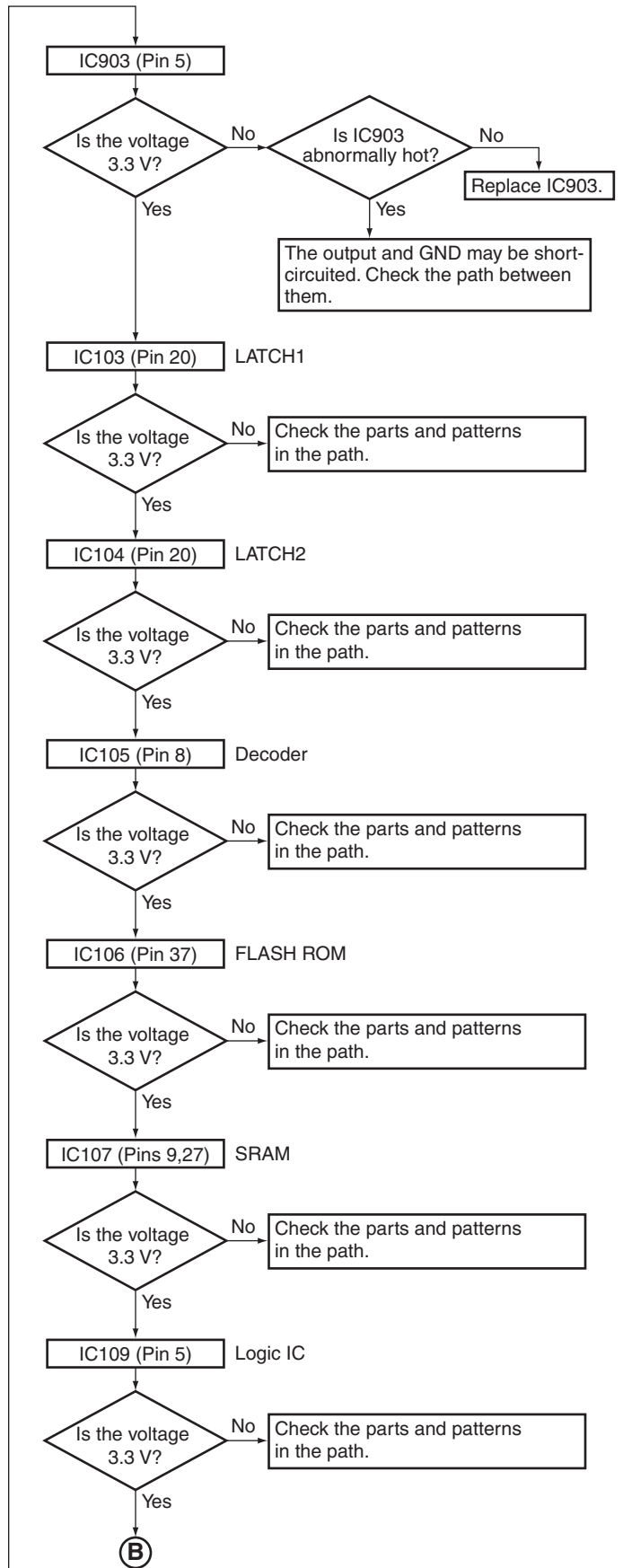
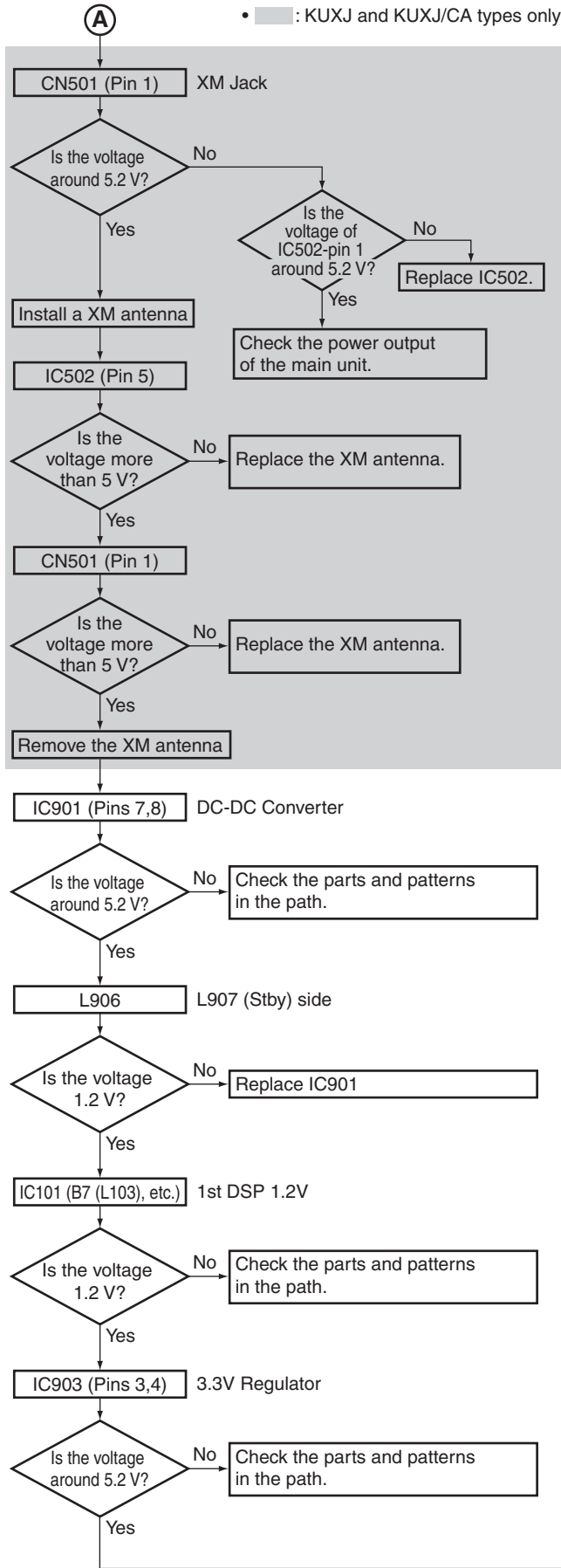

(B)

• [Grey Box]: KUXJ and KUXJ/CA types only

A

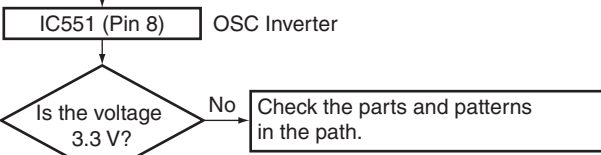

B

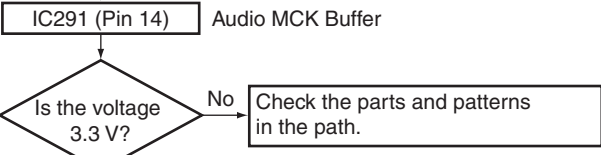

C

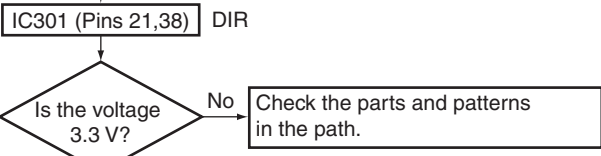

D

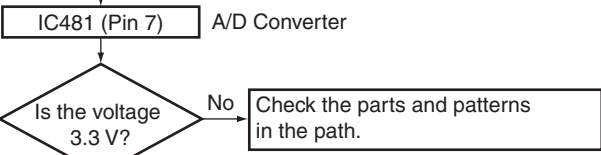

E

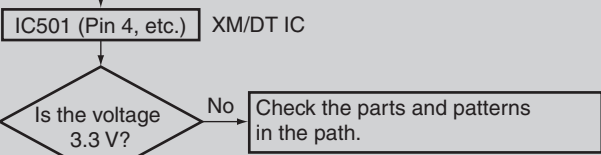
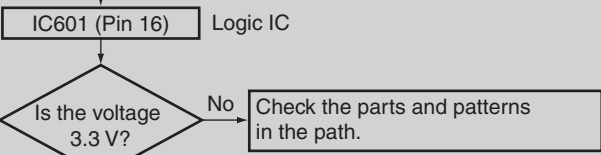
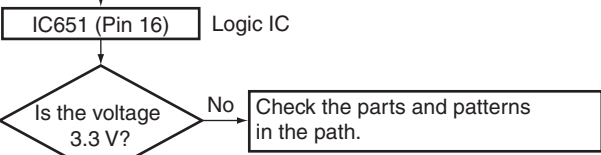

F

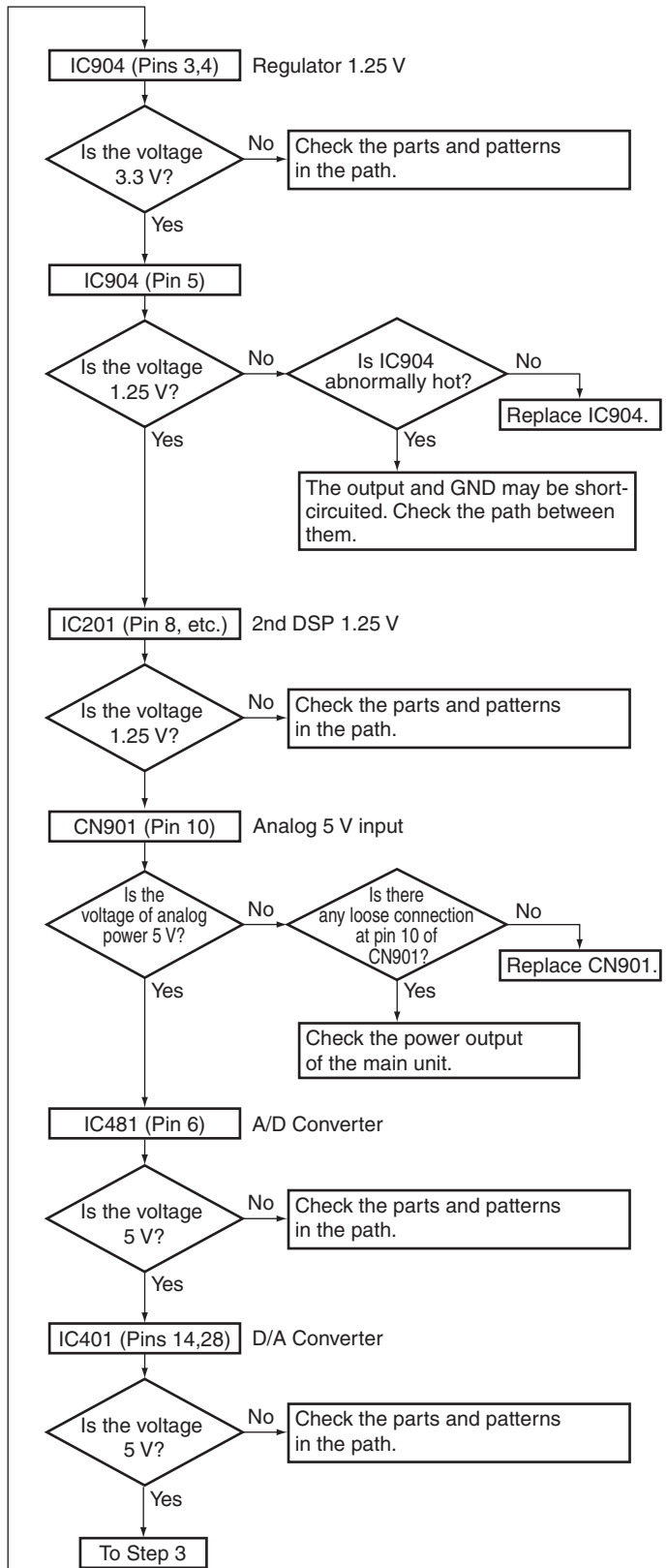

### Step 3: Operating Master Clock

- : KUXJ and KUXJ/CA types only

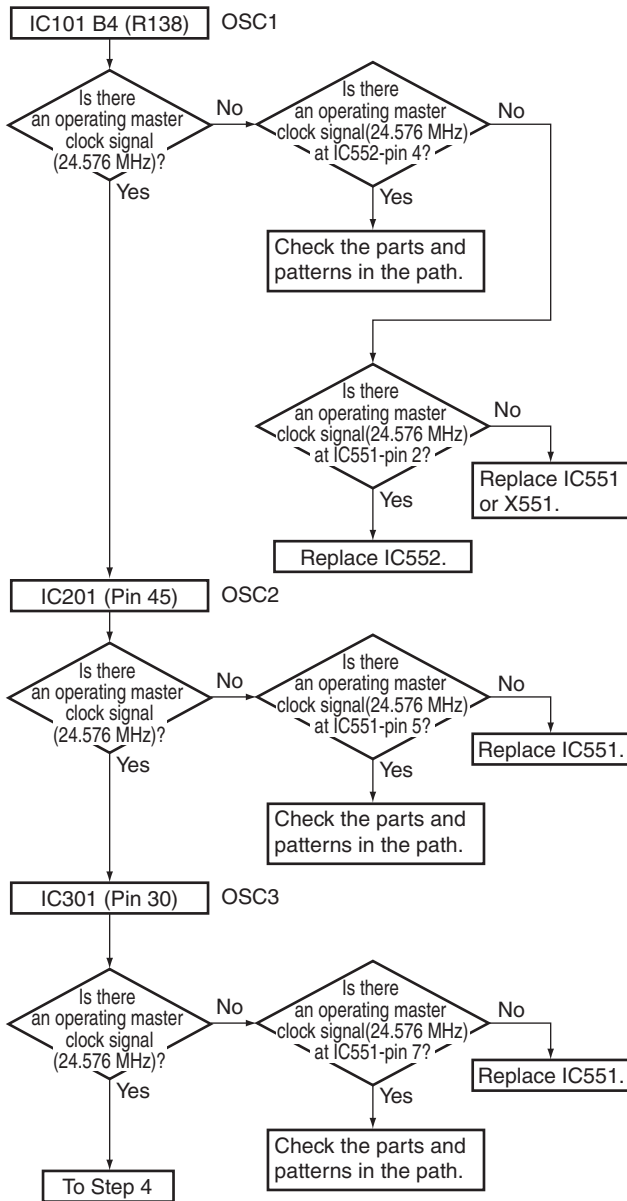

### Step 4: Audio Clock (Until Switch)

- When a sound is not out with the digital (COAX, OPT IN) signal input. → Go to Step 4-1
- When a sound is not out with the analog signal input. → Go to Step 4-2
- When a sound is not out with the HDMI. (It is assumed that failure diagnosis of HDMI Assy has been completed.) (I2S path)  
When the source is “dts HD Master Audio”, “Dolby True HD”, “PCM or LPCM at or above the sampling rate of 88.2kHz” or “LPCM Multi ch”. → Go to Step 4-3-1 (S/PDIF path)  
When the source is “dts HD High Resolution Audio”, “dts HD LBR”, “Dolby Digital Plus”, “2ch at or below the sampling rate of 48kHz”, or “other compression streams”. → Go to Step 4-1

(DSD)

When the source is SACD. → Go to Step 4-3-3

- When a sound is not out with the XM Radio. → Go to Step 4-4
- When a sound is not out with the USB (It is assumed that the failure diagnosis of USB Assy has been completed.) → Go to Step 4-5

except KU models

### Step 4-1: When a sound is not out with the digital (COAX, OPT IN) signal input

When the source in the digital (COAX, OPT IN) or the HDMI path is “dts HD High Resolution Audio”, “dts HD LBR”, “Dolby Digital Plus”, “2ch at or below the sampling rate of 48kHz” or “other compression streams”. Check that changes by pulling out and inserting the digital input lines. (Function is able to change the assignment. Therefore it is not specified.)

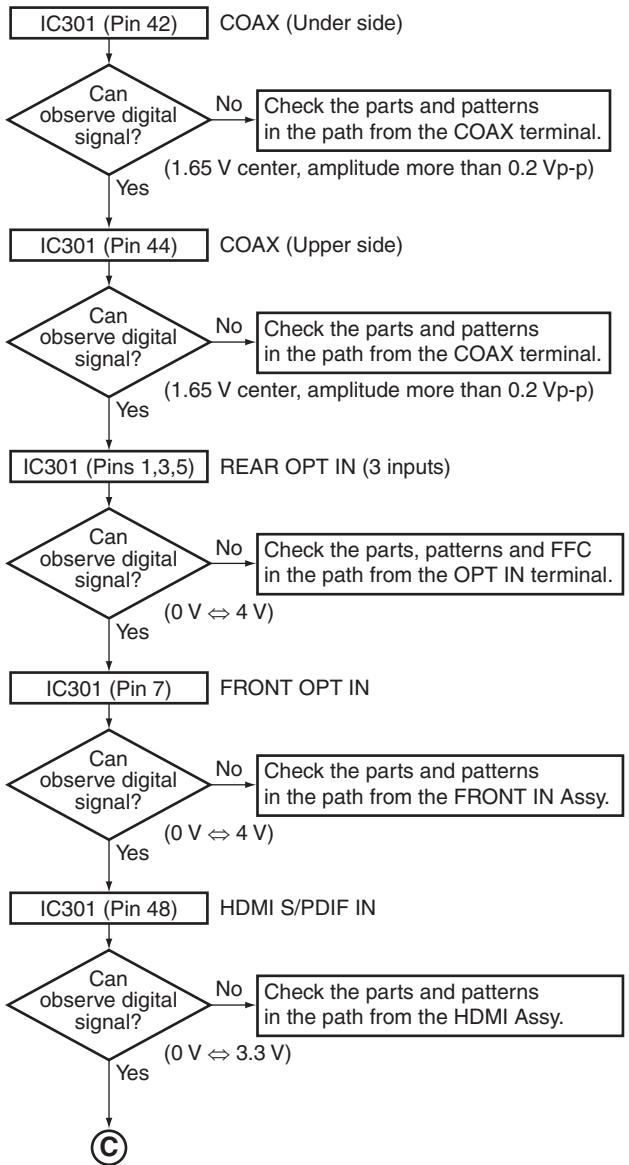

Ⓢ

• [shaded box] : KUXJ and KUXJ/CA types only

A

Input a digital signal and check with the state which selected the function.

IC601 (Pin 1) XMSW3

Is the voltage 0 V?

No: Check the path to the microcomputer.

Yes

B

IC651 (Pin 1) HDSW

Is the voltage 0 V?

No: Check the path to the microcomputer.

Yes

C

IC301 (Pin 23) DIRM

Is there a master clock output (24.576 MHz)?

No

Is the voltage of IC301-pin 31 3.3 V?

No

Check the path to the microcomputer.

Yes

Is the output of IC301-pin 36 (DRERR3) 0 V?

No

Replace IC301 or IC651 (IC601).

D

IC601 (Pin 11)

Is there a master clock input (24.576 MHz)?

No

Is there abnormality at the parts and patterns in the input path?

No

Replace IC301 or IC601.

Yes

E

IC651 (Pin 11)

Is there a master clock input (24.576 MHz)?

No

Is there abnormality at the parts and patterns in the input path?

No

Replace IC301 (IC601) or IC651.

Yes

F

IC301 (Pin 24) DIRL

Is there a LR clock output?

No

Is there abnormality at the parts and patterns in the output path?

No

Replace IC301 or IC651 (IC601).

Yes

IC601 (Pin 14)

Is there a LR clock input?

No

Is there abnormality at the parts and patterns in the input path?

No

Replace IC301 or IC601.

Yes

IC651 (Pin 14)

Is there a LR clock input?

No

Is there abnormality at the parts and patterns in the input path?

No

Replace IC301 (IC601) or IC651.

Yes

IC301 (Pin 25) DIRD

Is there a audio data output?

No

Is there abnormality at the parts and patterns in the output path?

No

Replace IC301 or IC651 (IC601).

Yes

IC601 (Pin 2)

Is there a audio data input?

No

Is there abnormality at the parts and patterns in the input path?

No

Replace IC301 or IC601.

Yes

IC651 (Pin 2)

Is there a audio data input?

No

Is there abnormality at the parts and patterns in the input path?

No

Replace IC301 (IC601) or IC651.

Yes

IC301 (Pin 26) DIRB

Is there a bit clock output?

No

Is there abnormality at the parts and patterns in the output path?

No

Replace IC301 or IC651 (IC601).

Yes

Ⓢ

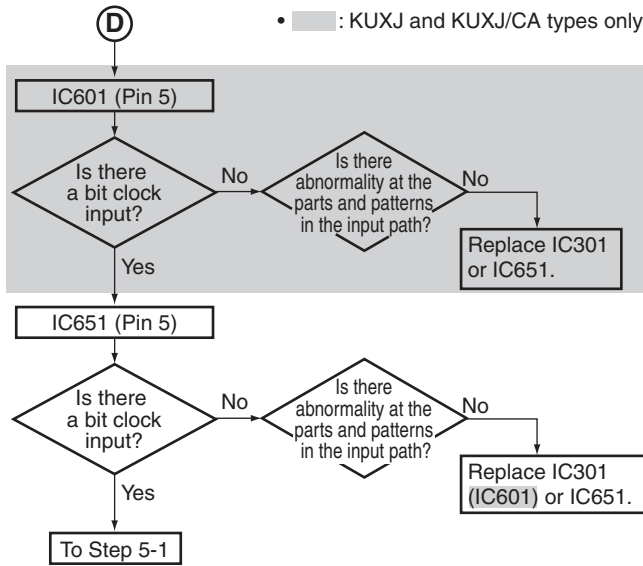

**Step 4-2: When a sound is not out with the analog signal input**

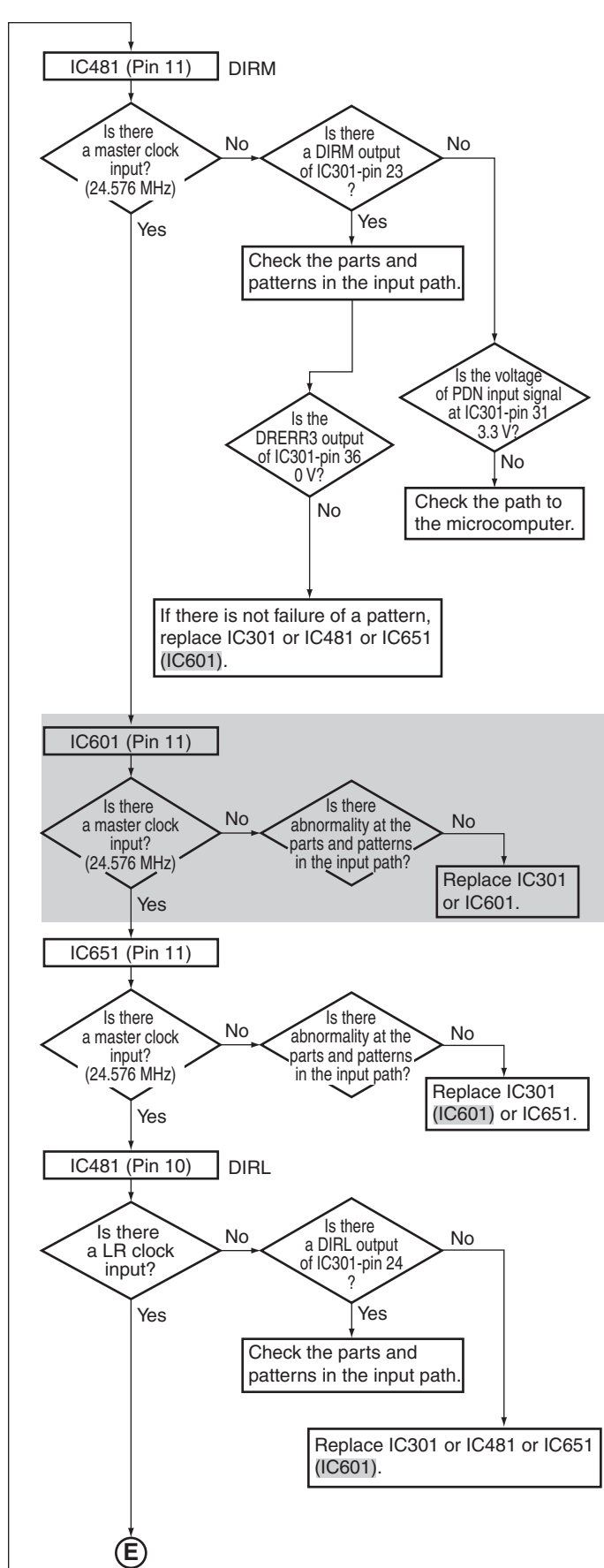
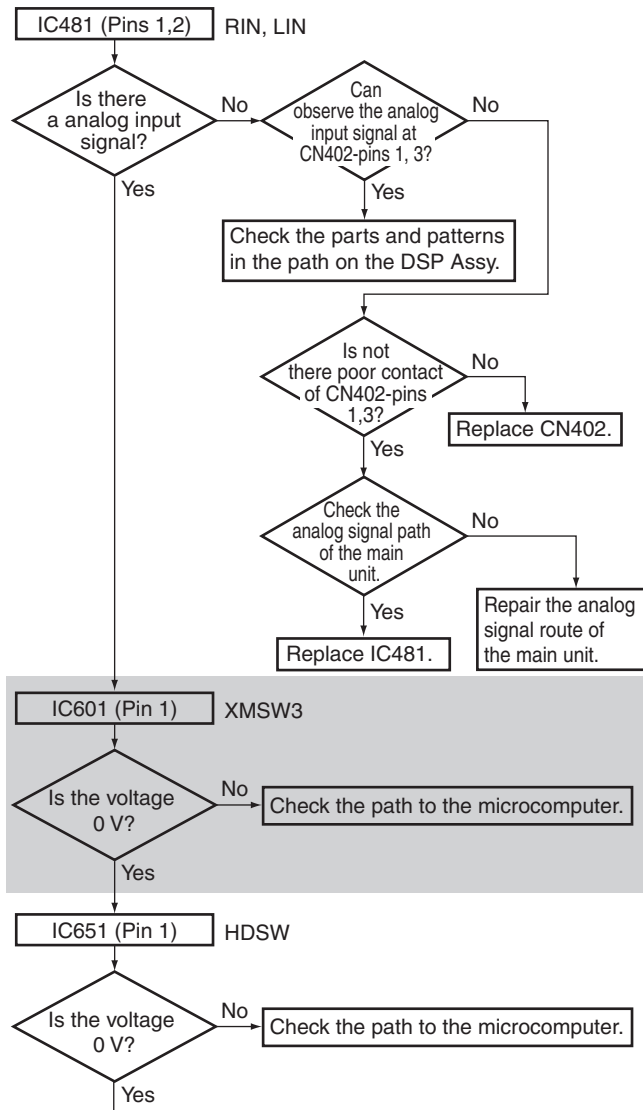

• ■ : KUXJ and KUXJ/CA types only

(E)

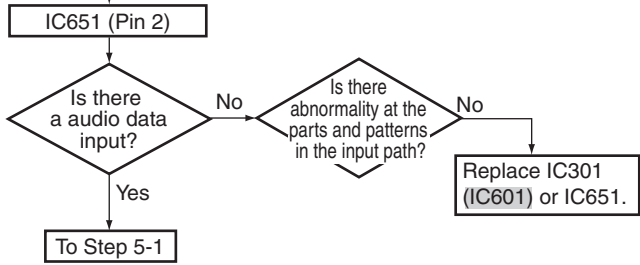
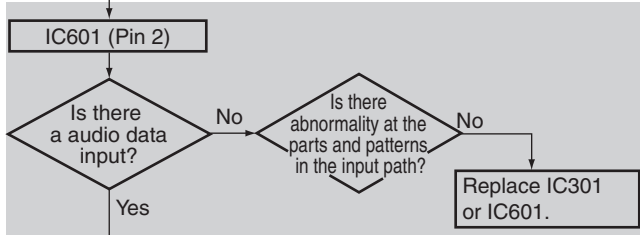
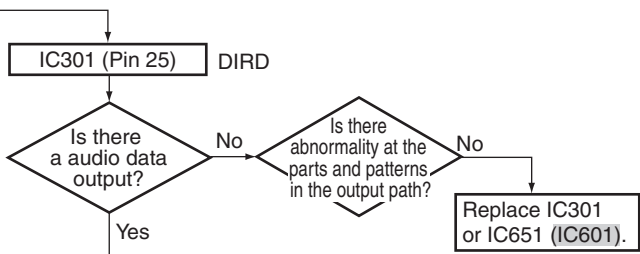
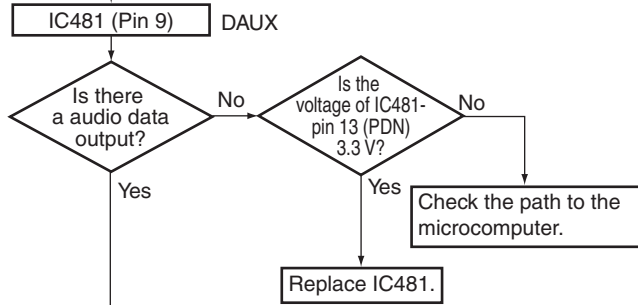
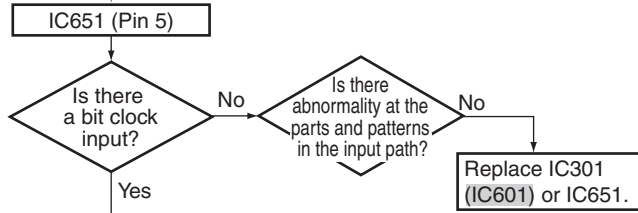
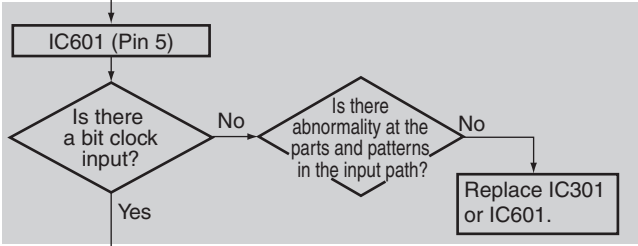
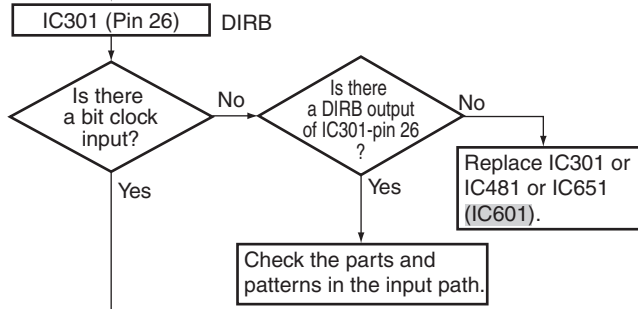
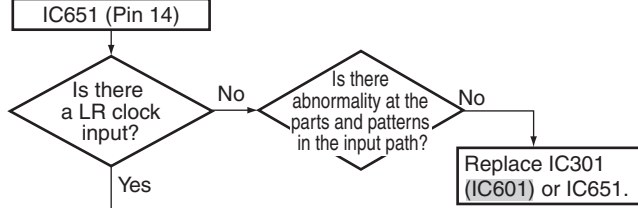
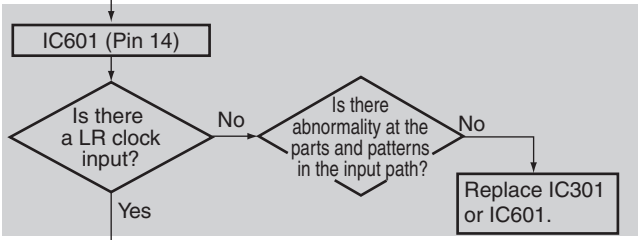

**Step 4-3-1: When a sound is not out with the HDMI (When the source is “dts HD Master Audio”, “Dolby True HD”, “PCM or LPCM at or above the sampling rate of 88.2kHz” or “LPCM Multi ch”)**

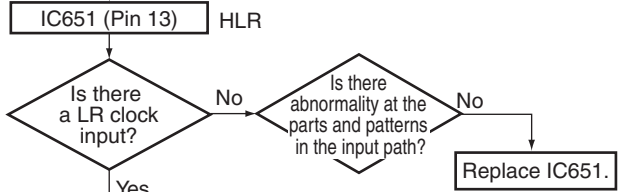
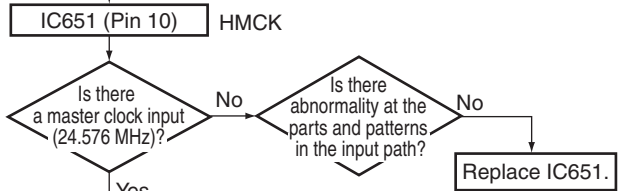
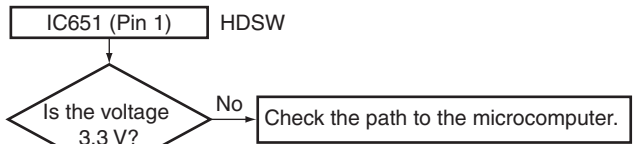

(F)

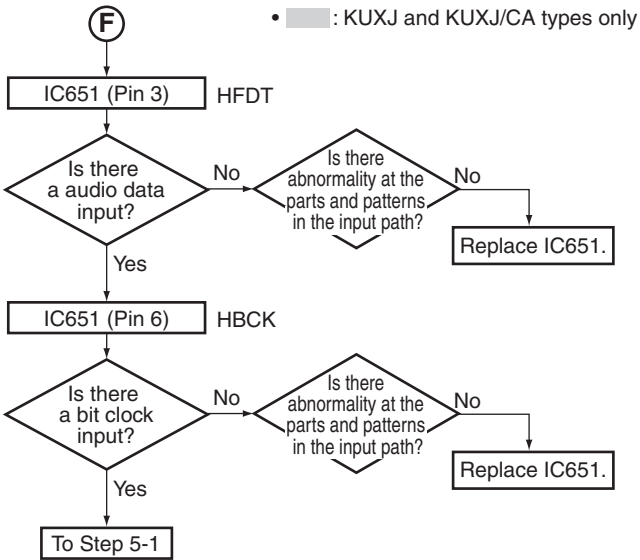

### Step 4-3-2: When a sound is not out with the HDMI (When the source is SACD)

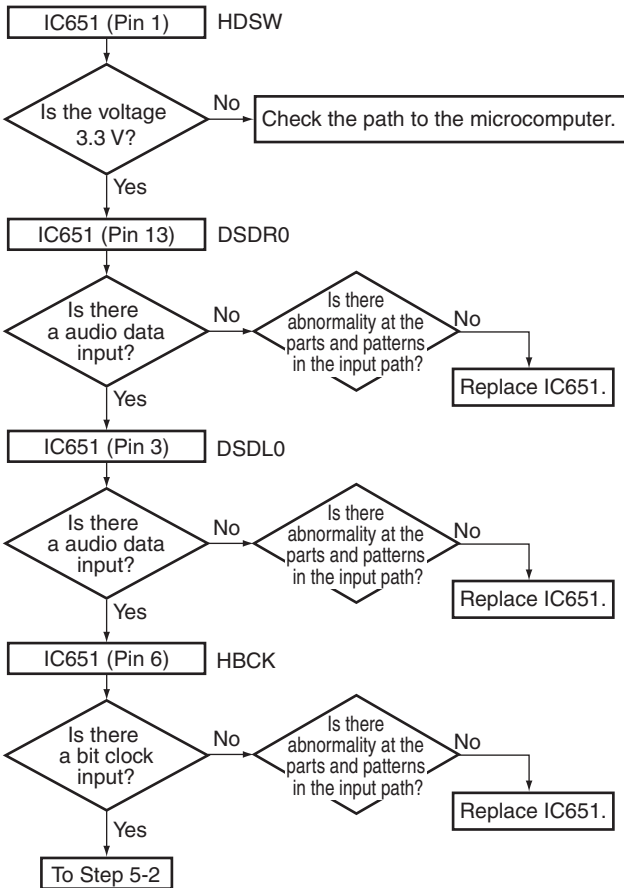

### Step 4-4: When a sound is not out with the XM Radio

Insert the XM Antenna and check it.

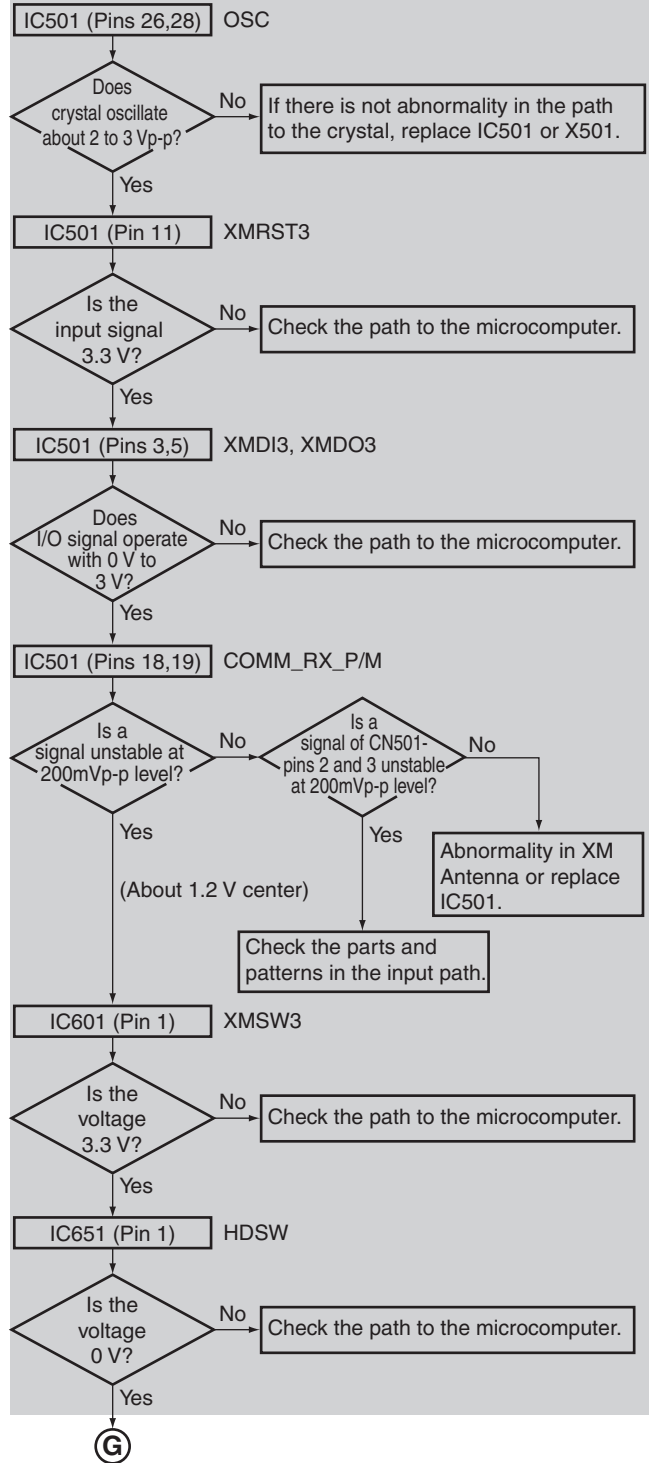

• [Grey Box] : KUXJ and KUXJ/CA types only

ⓐ

A

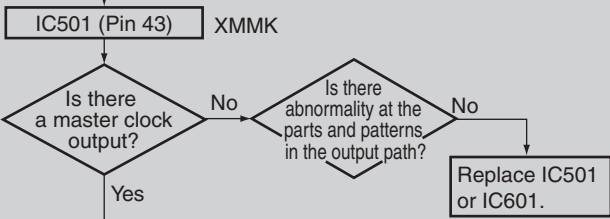

B

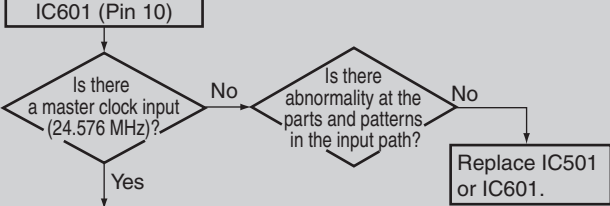

C

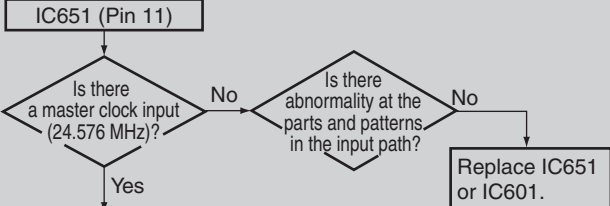

D

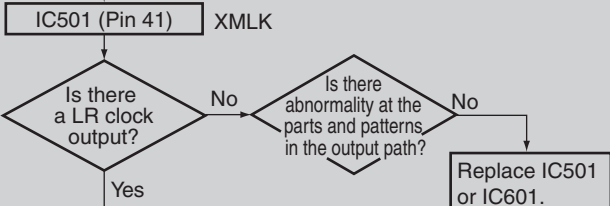

E

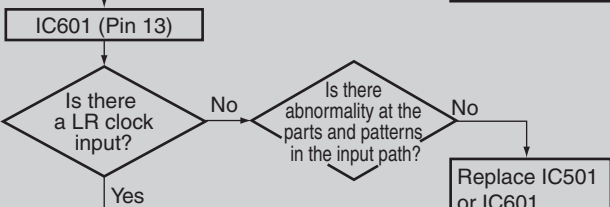

F

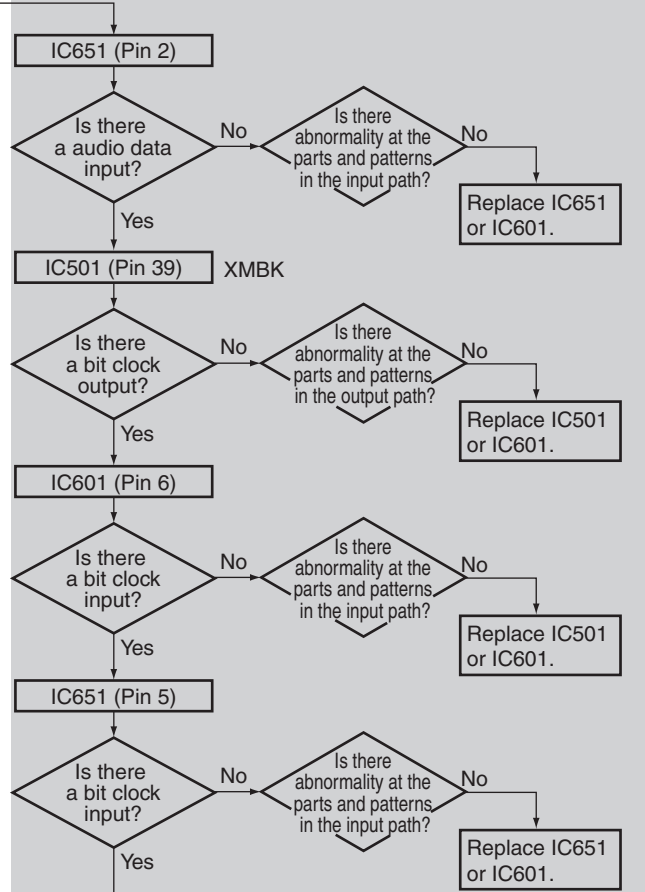
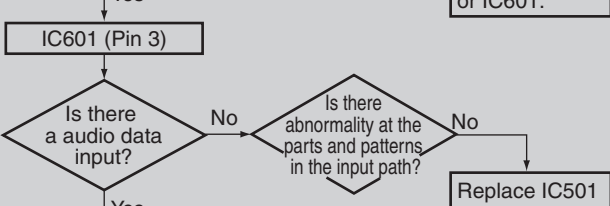
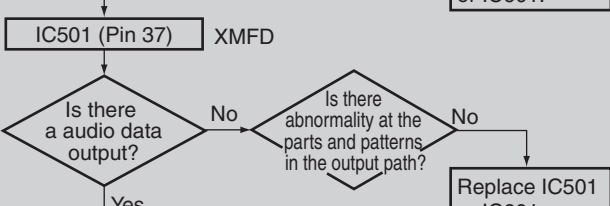
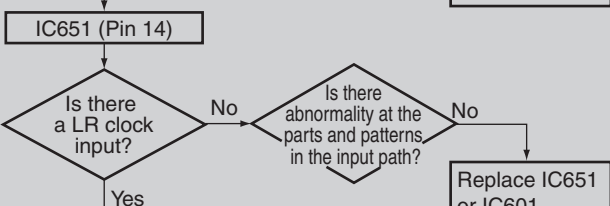

### Step 4-5: When a sound is not with the USB (except KU models)

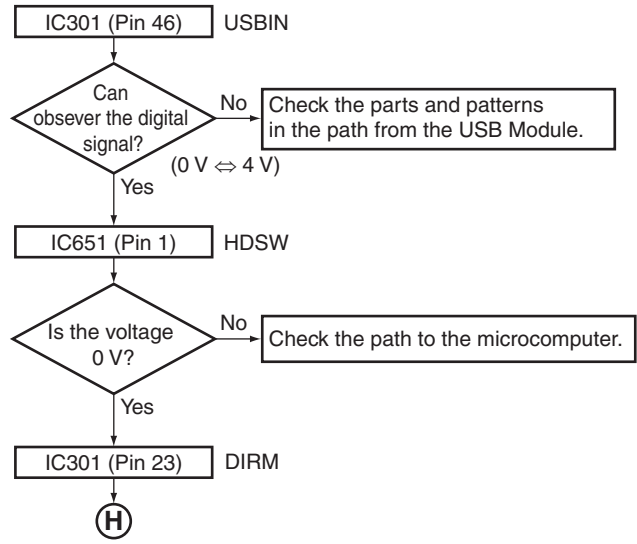

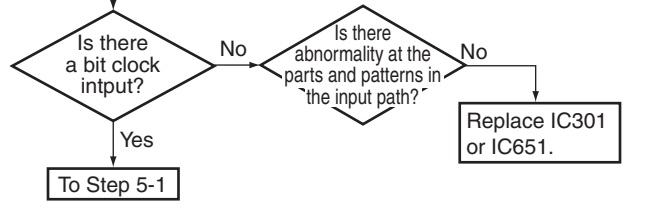
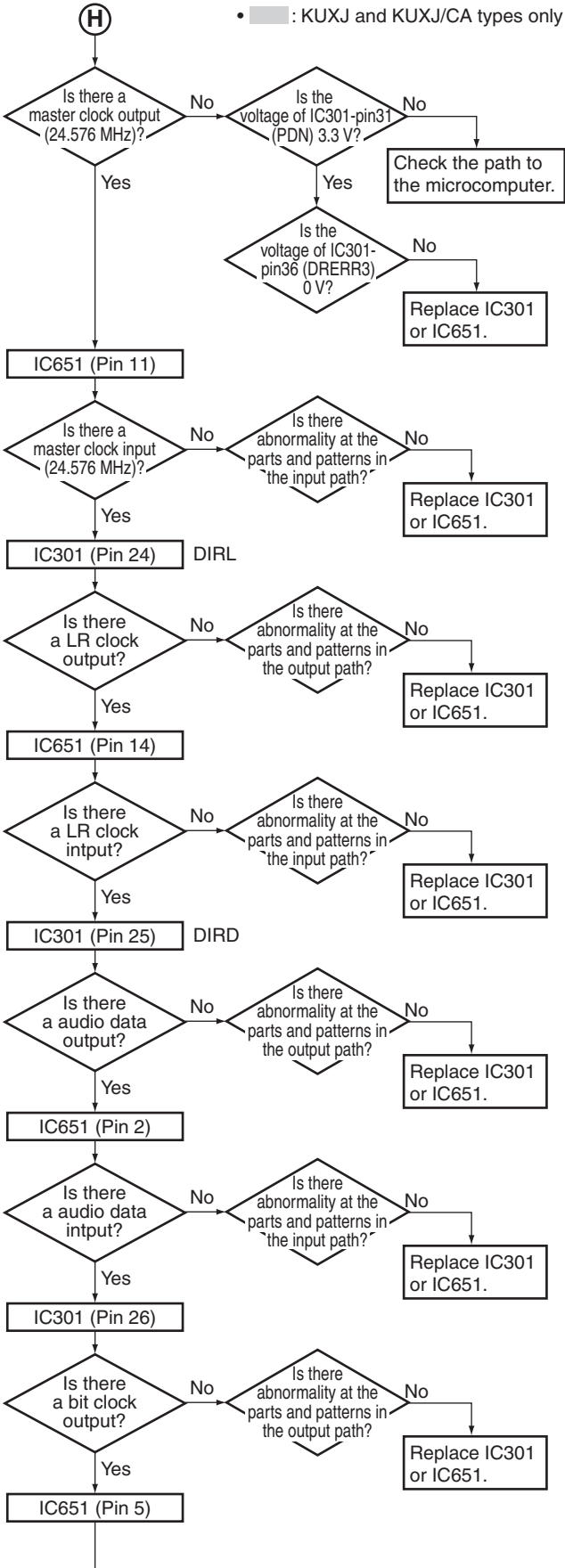

**Step 5-1: Audio Clock (from Switch to 1st DSP)**

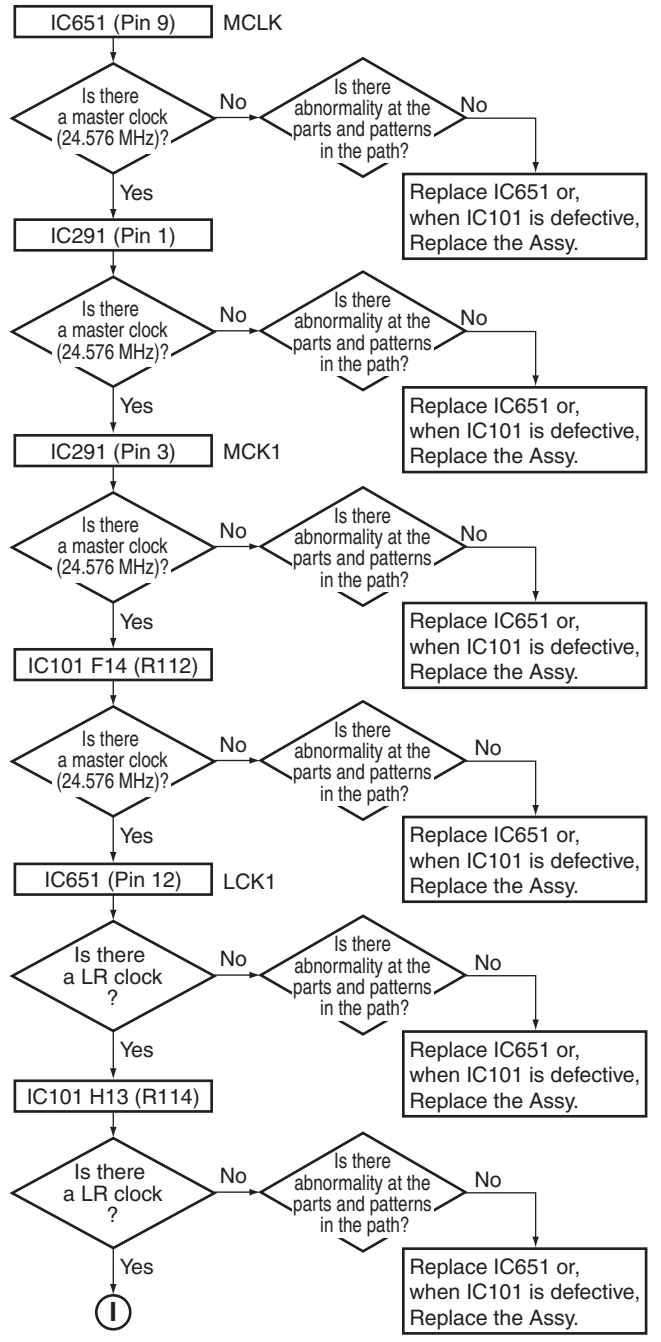

### Step 5-2: Audio Clock & Data (in the case of SACD to 1st DSP)

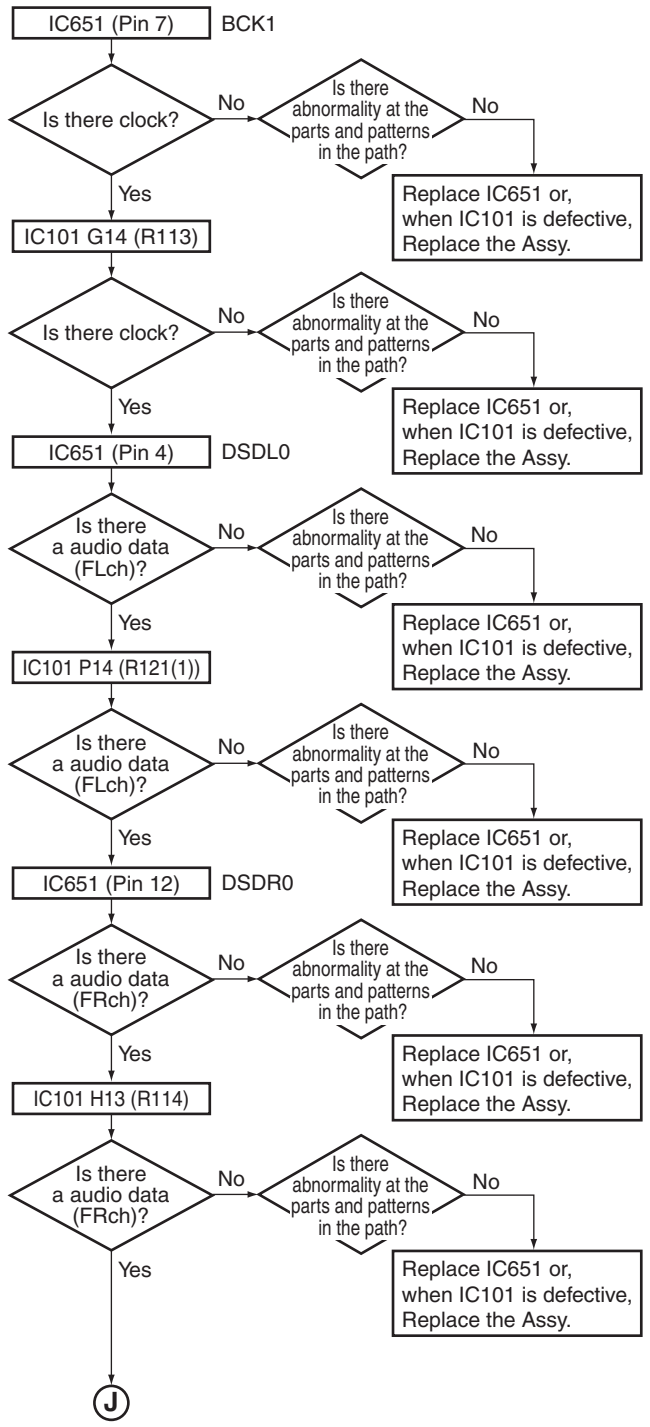
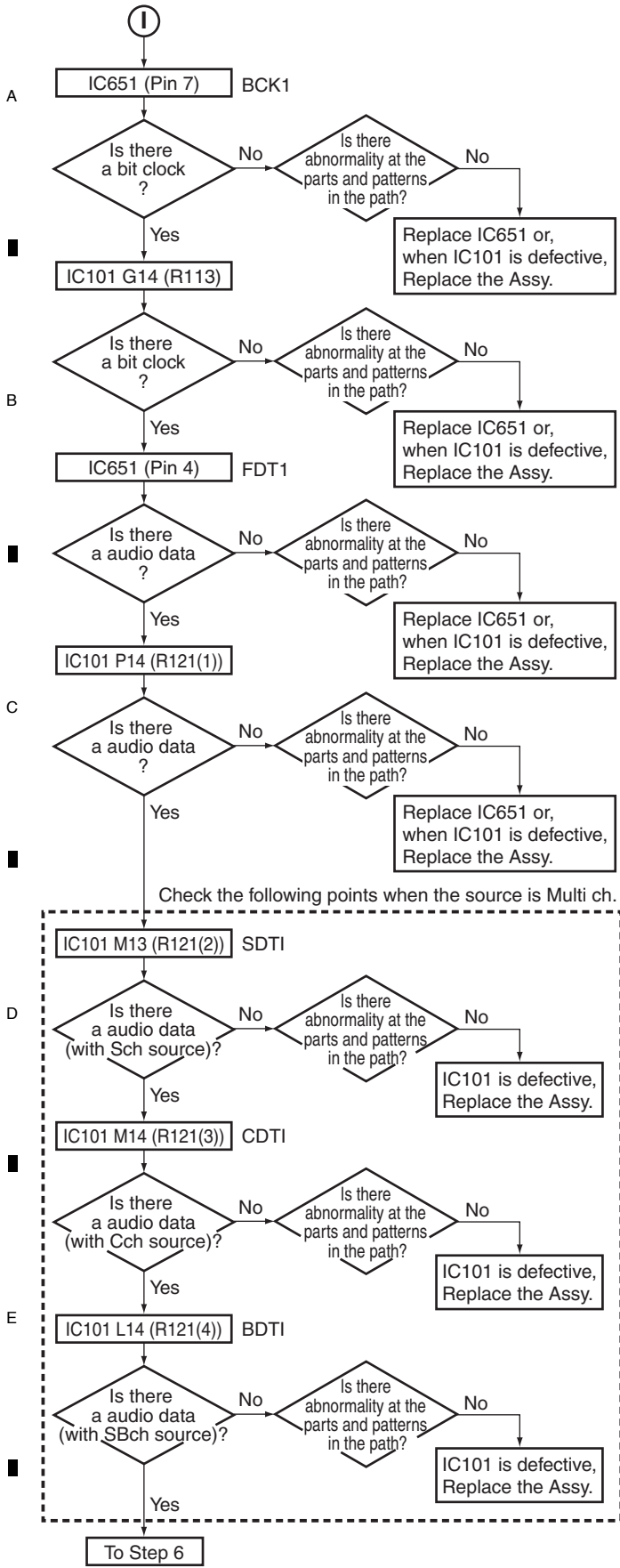

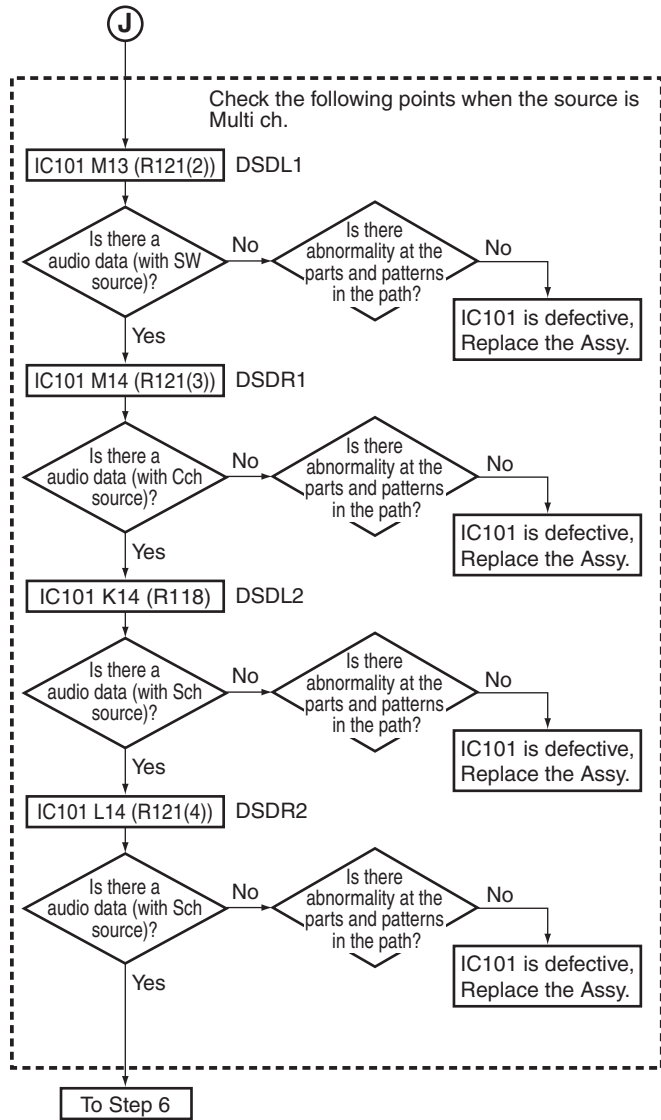

**Step 6: Audio Clock (from 1st DSP to 2nd DSP)**

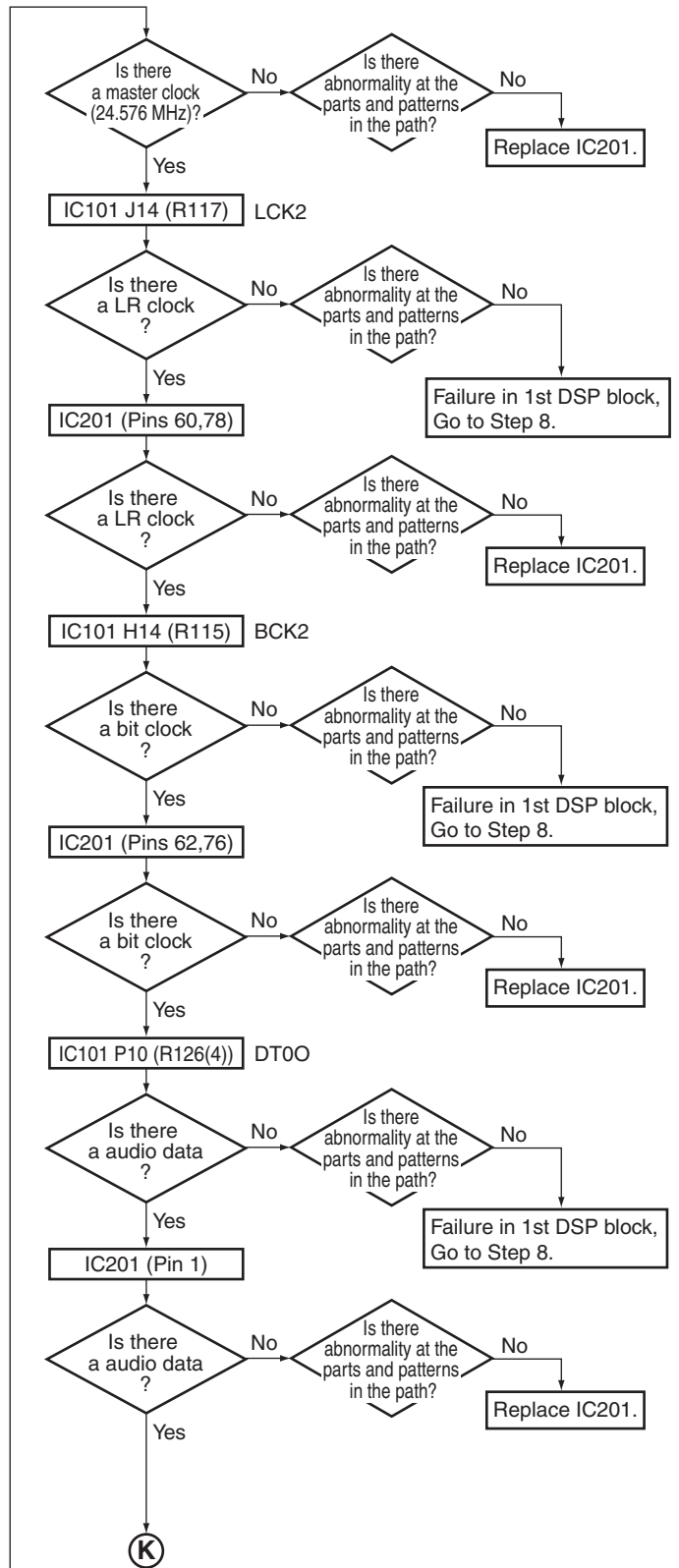
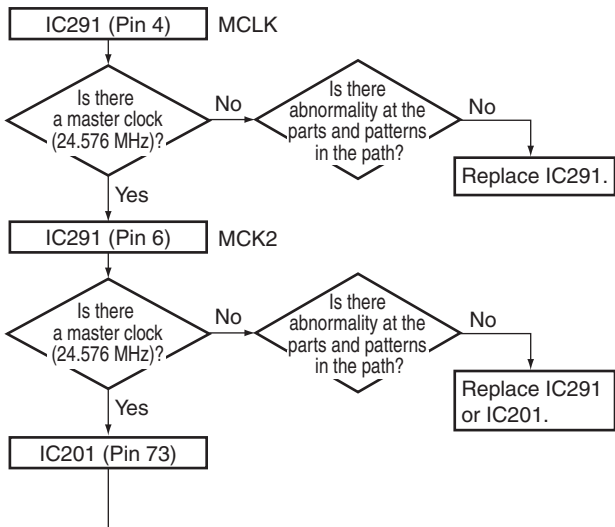

(K)

### Step 7: Audio Clock (from 2nd DSP to the DAC output)

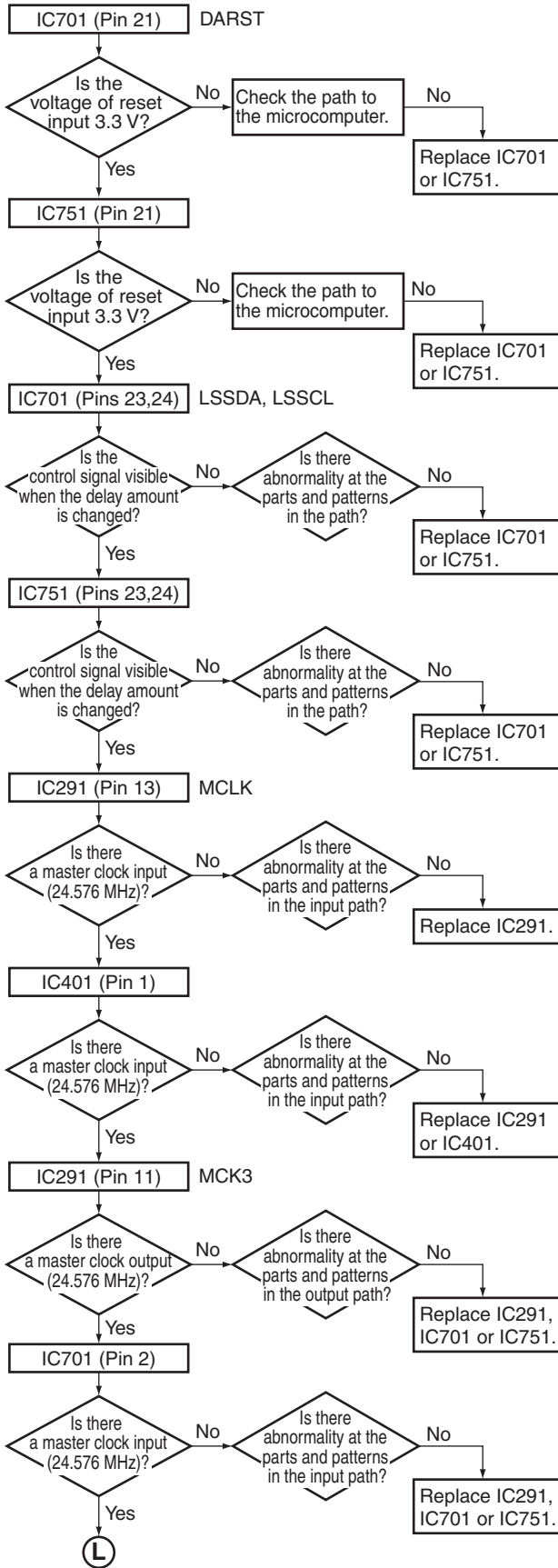
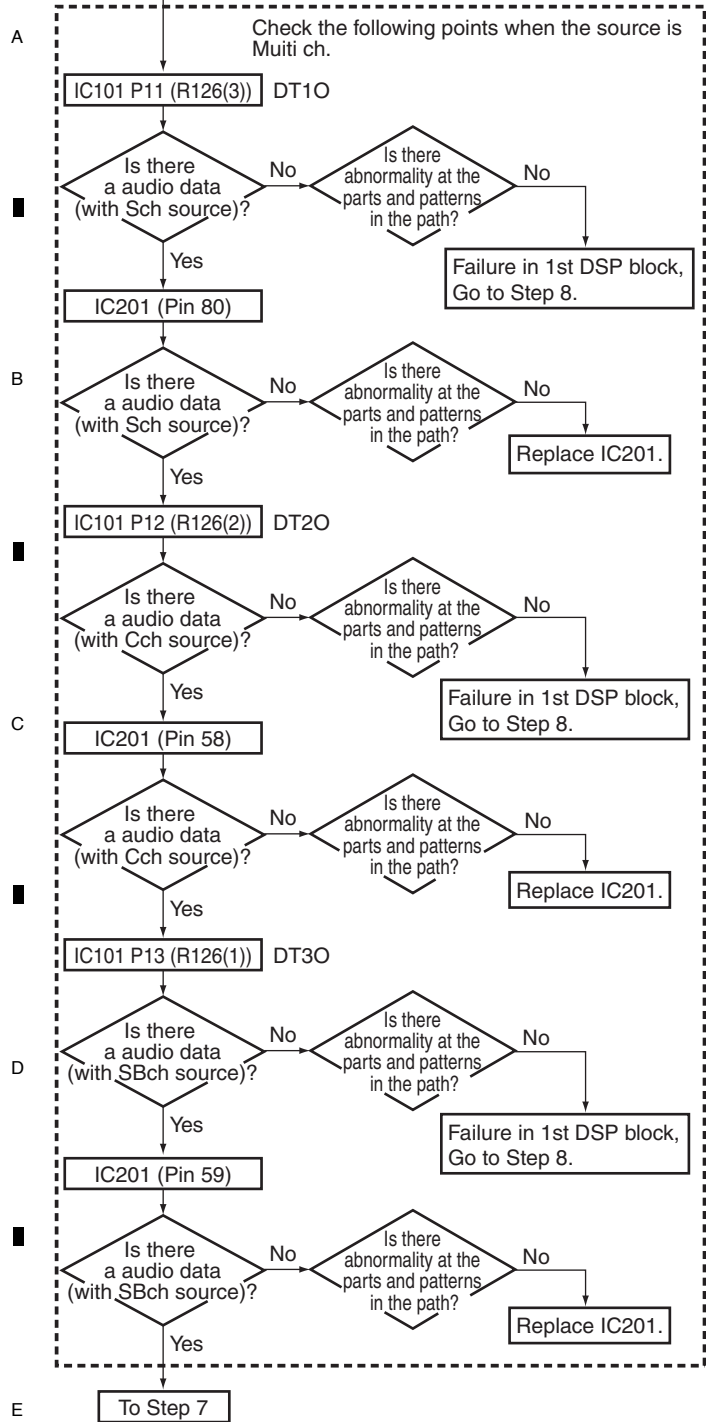

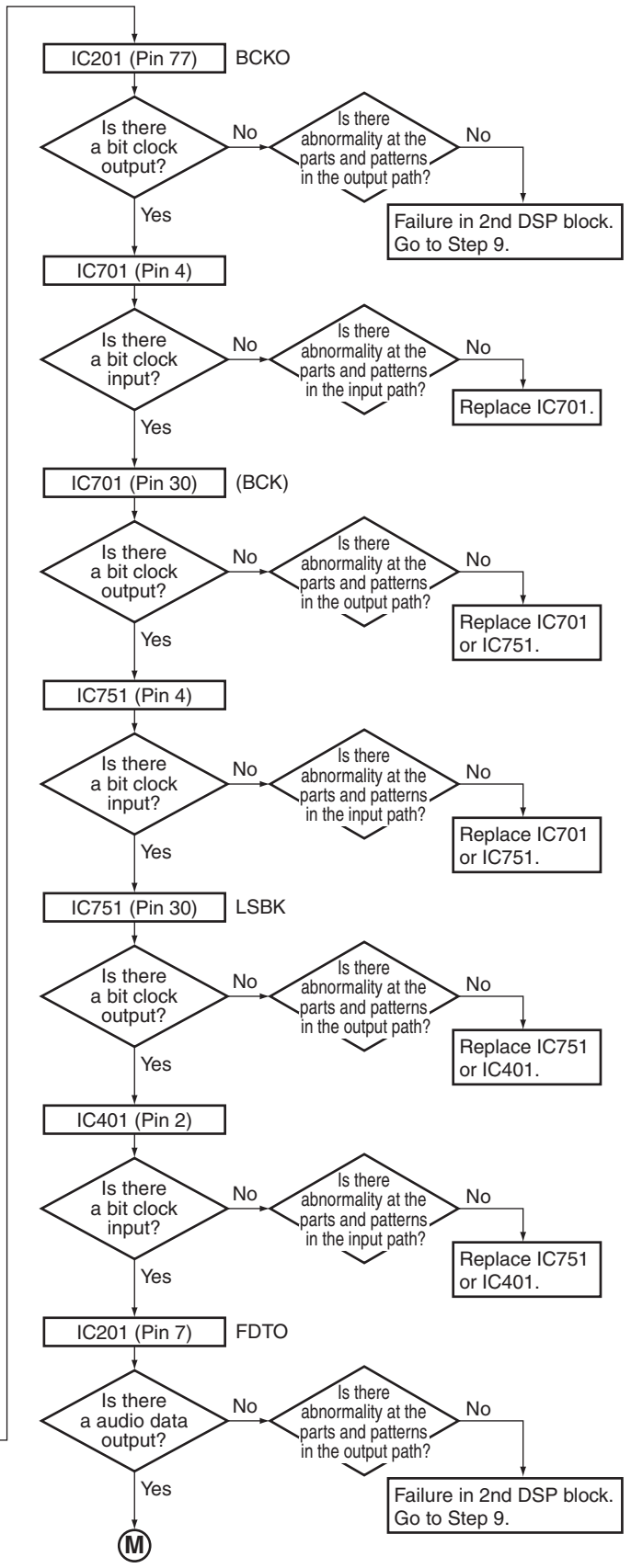
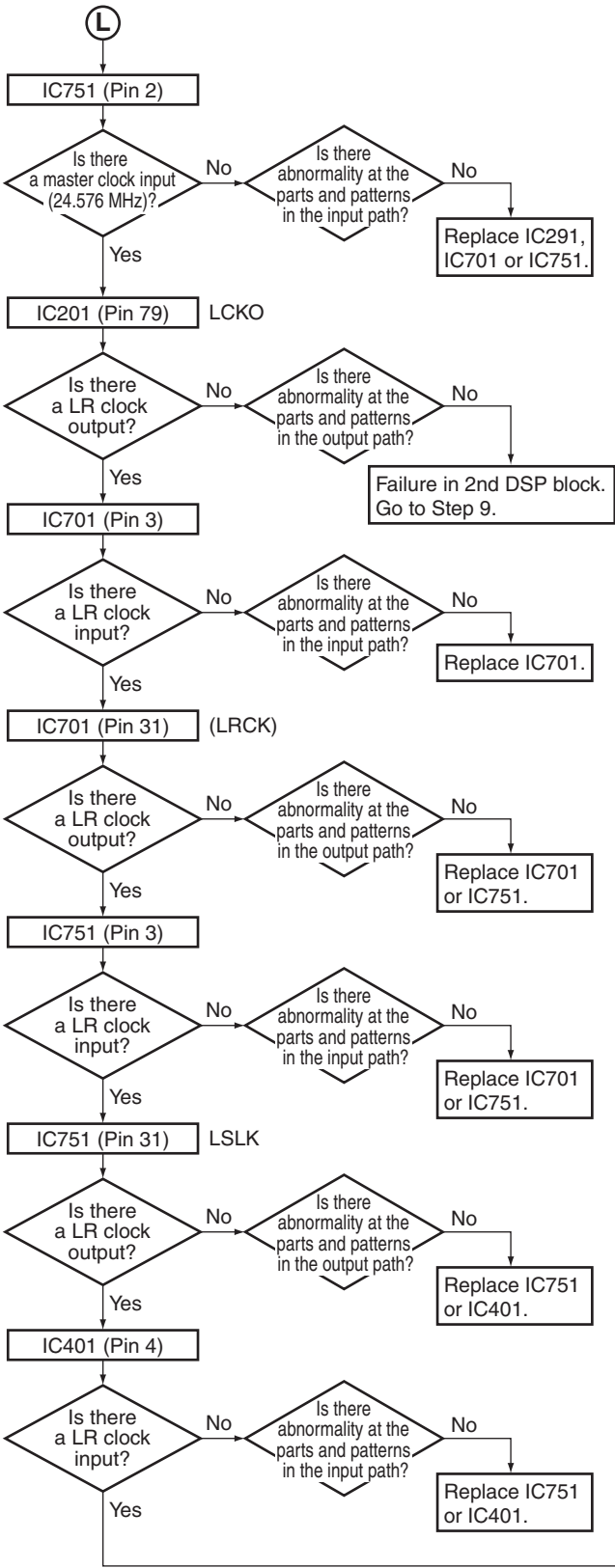

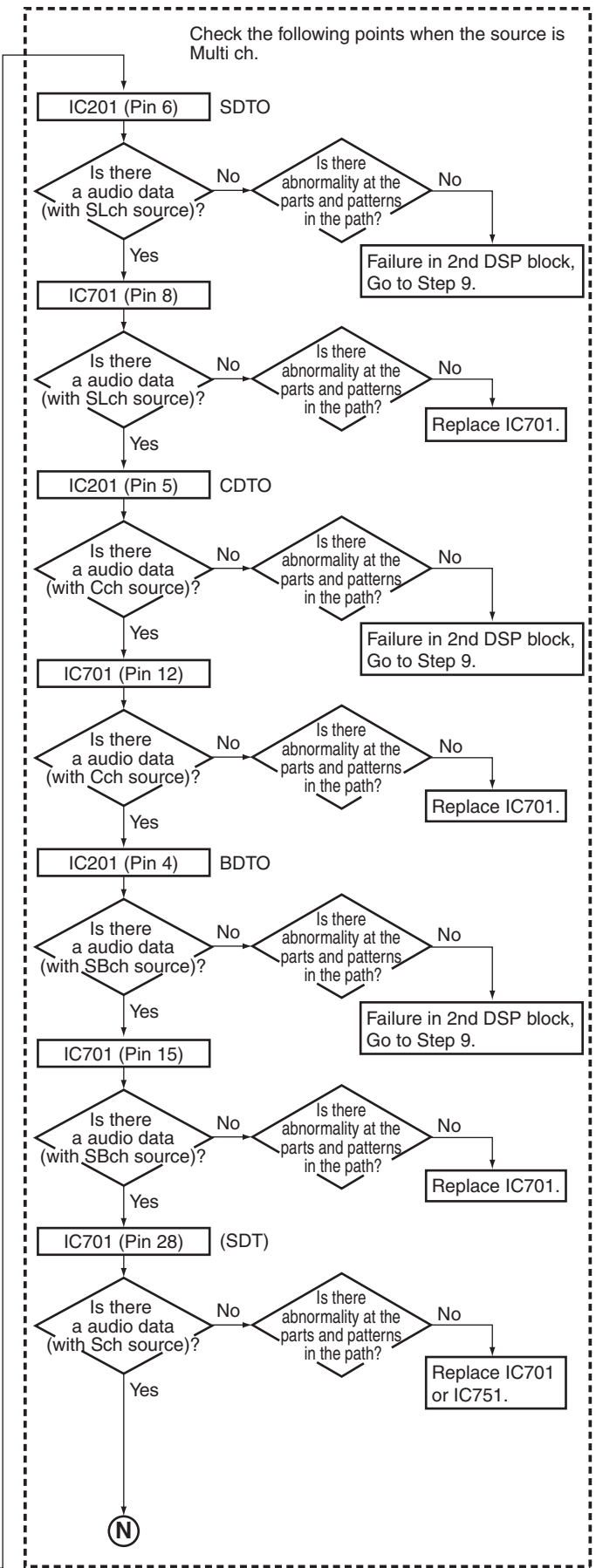
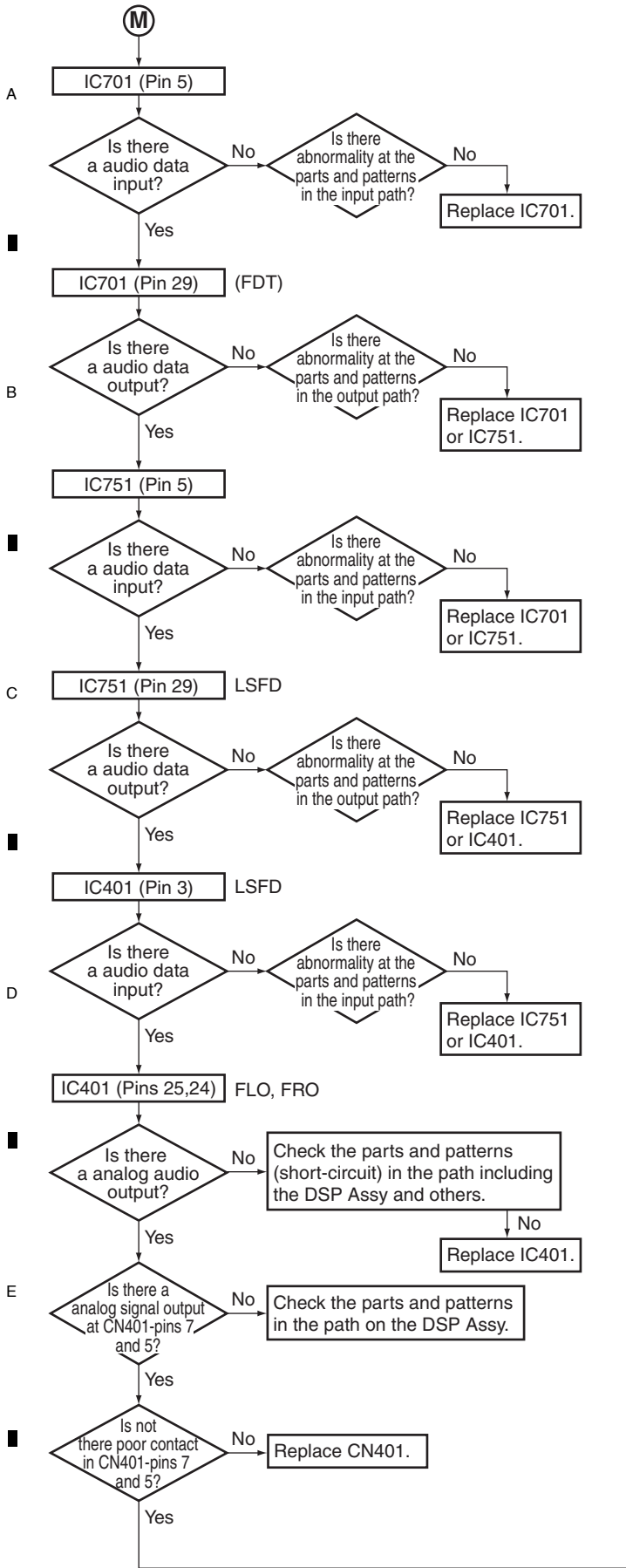

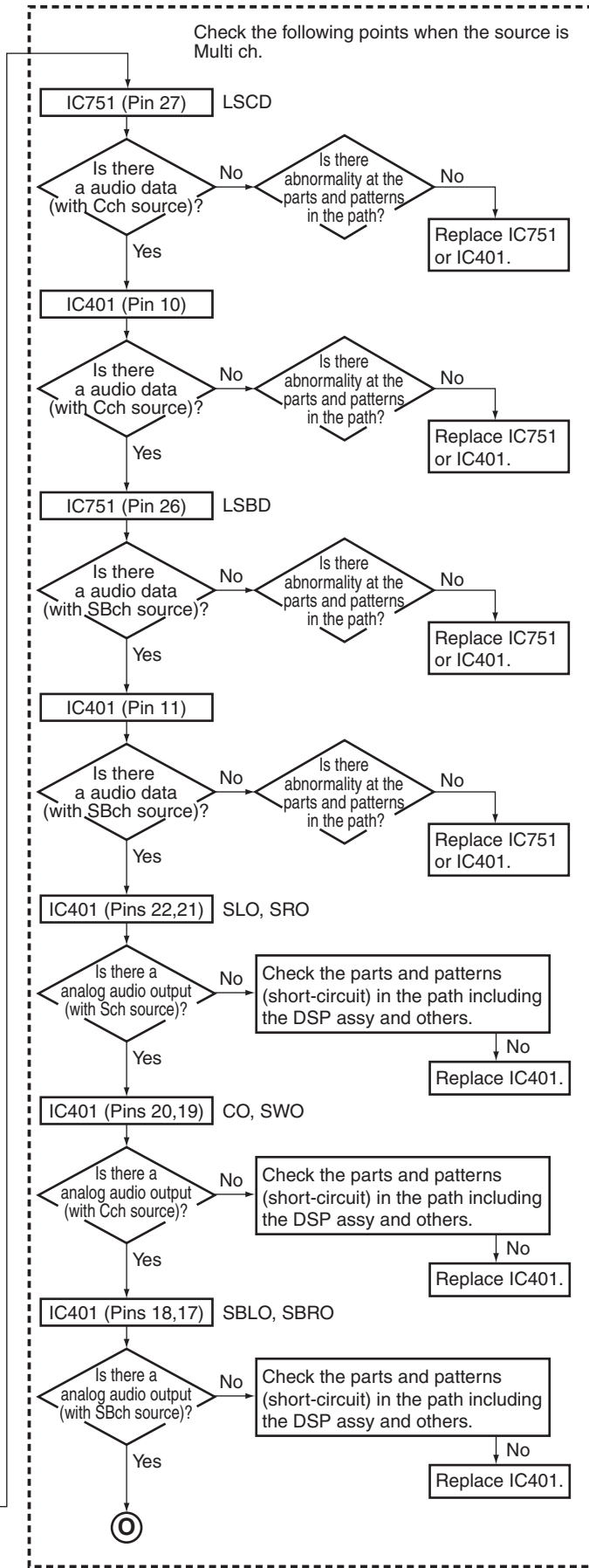
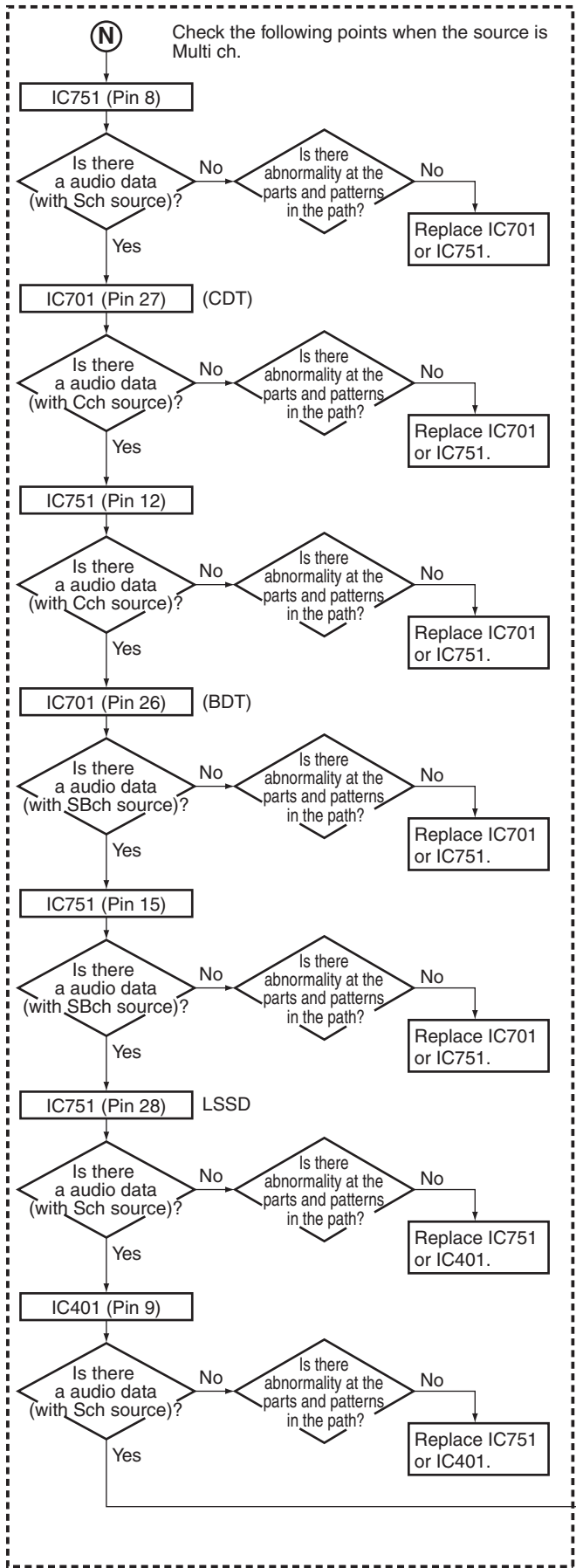

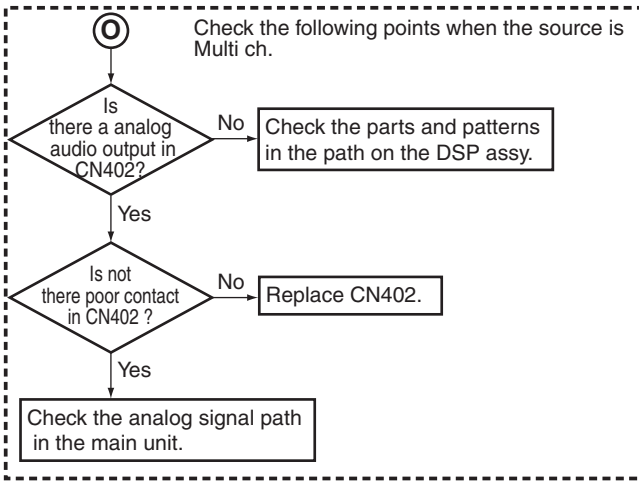

### Step 8: 1st DSP

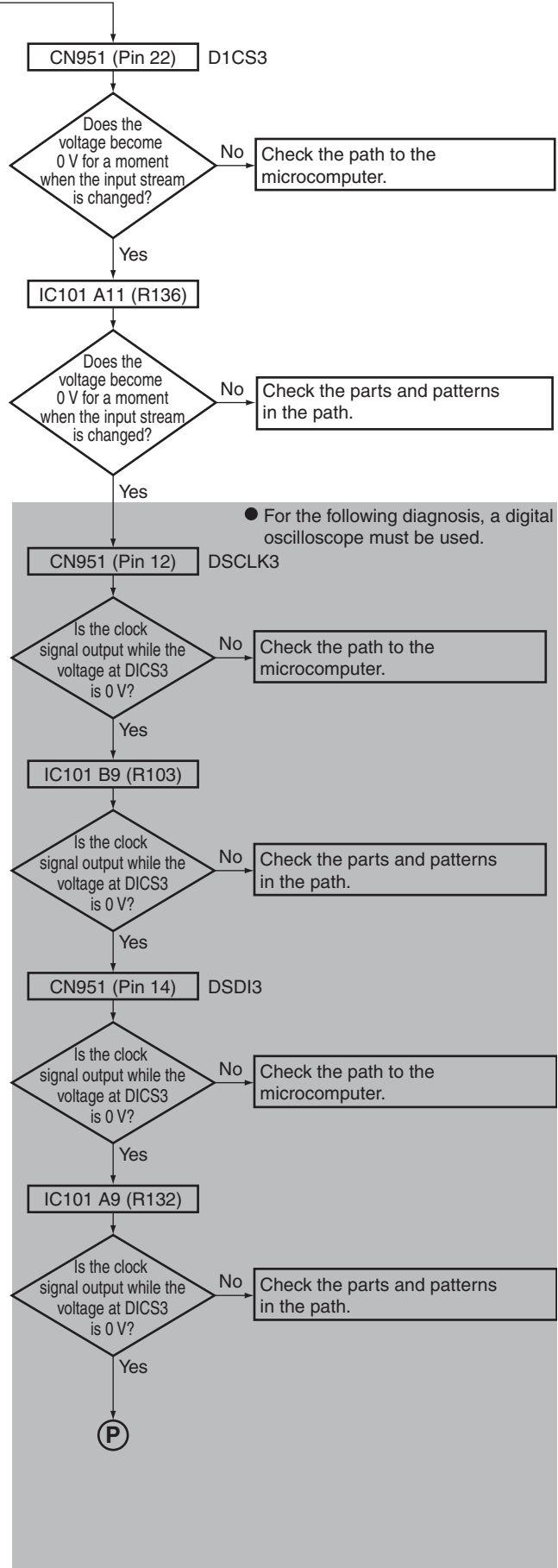
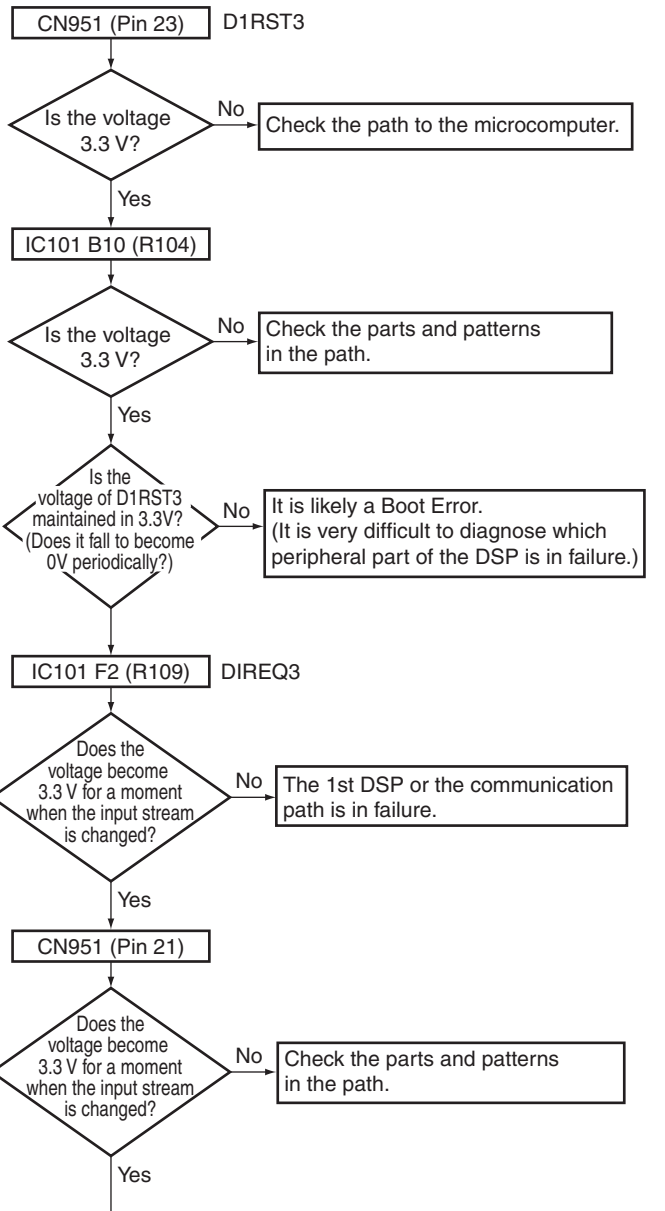

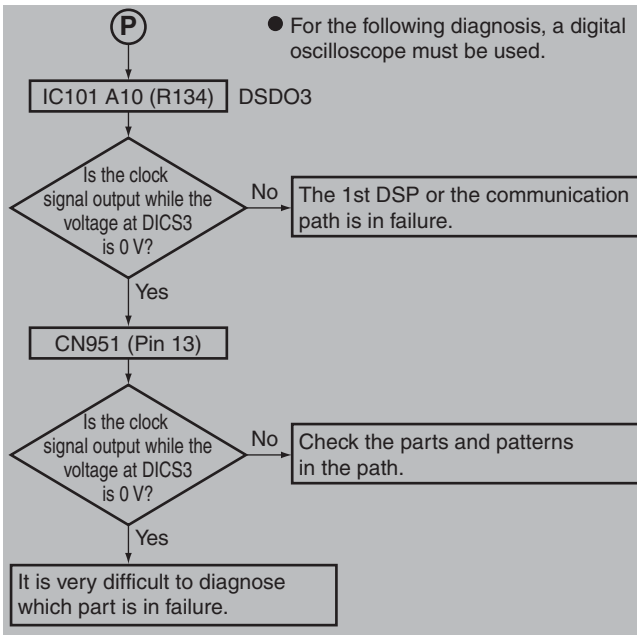

### Step 9: 2nd DSP

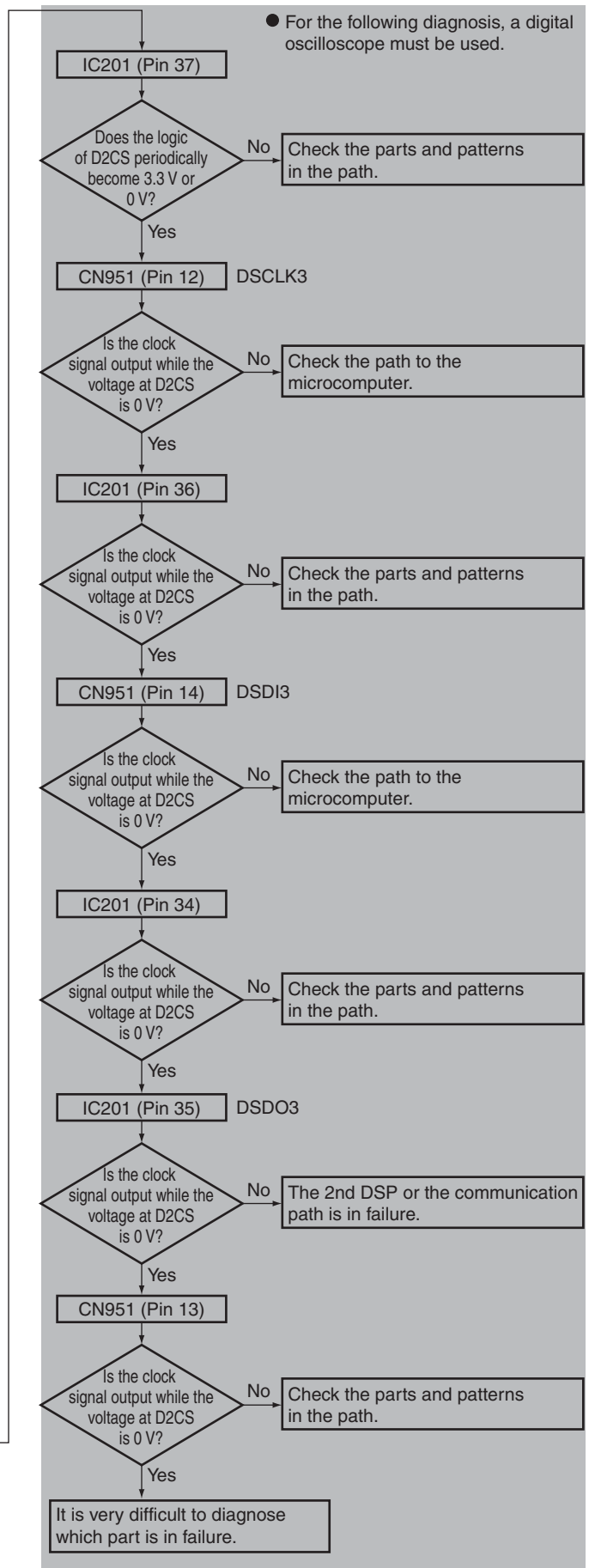
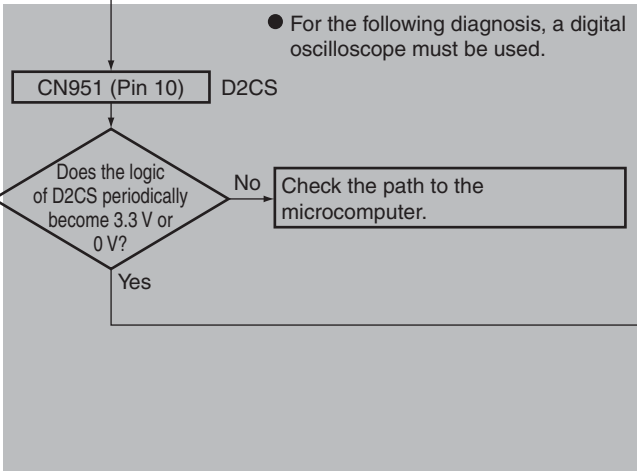
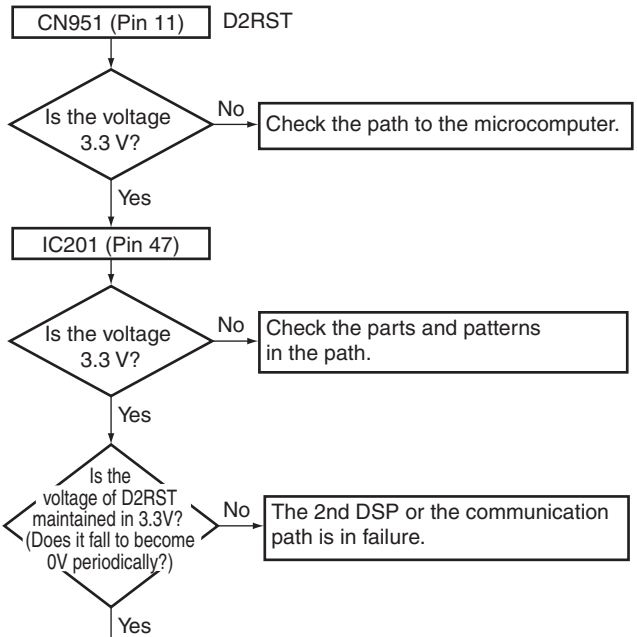

# DSP Block Diagram

## Signal Block

- : For AWX8813 only (for North American specifications)
- ⋯: Stand-by parts, stand-by path
- ( ) : Channel allocation for SACD

- : I2S MCLK
- : I2S DATA (2ch) \*F, S, C and B before pin numbers mean FL/FRch, SL/SRch, C/SWch and SBL/SBRch, respectively.
- : I2S DATA (Compressed (includes dts HD High Resolution Audio, dts HD LBR, and Dolby Digital Plus), (48K for HDMI))
- : I2S LRCK, MBCK

- ⋯→ : Control, memory bus line, etc
- ⇌ : Analog audio signal \*Alphabets before pin numbers mean the channel names.
- : SPDIF, Operation Clock, etc
- : I2S or DSD DATA (Signal from HDMI. When it is "dts HD Master Audio", "Dolby True HD", "SACD", "LPCM Multi" or "PCM or LPCM at or above 88.2kHz")

A

B

C

D

E

F

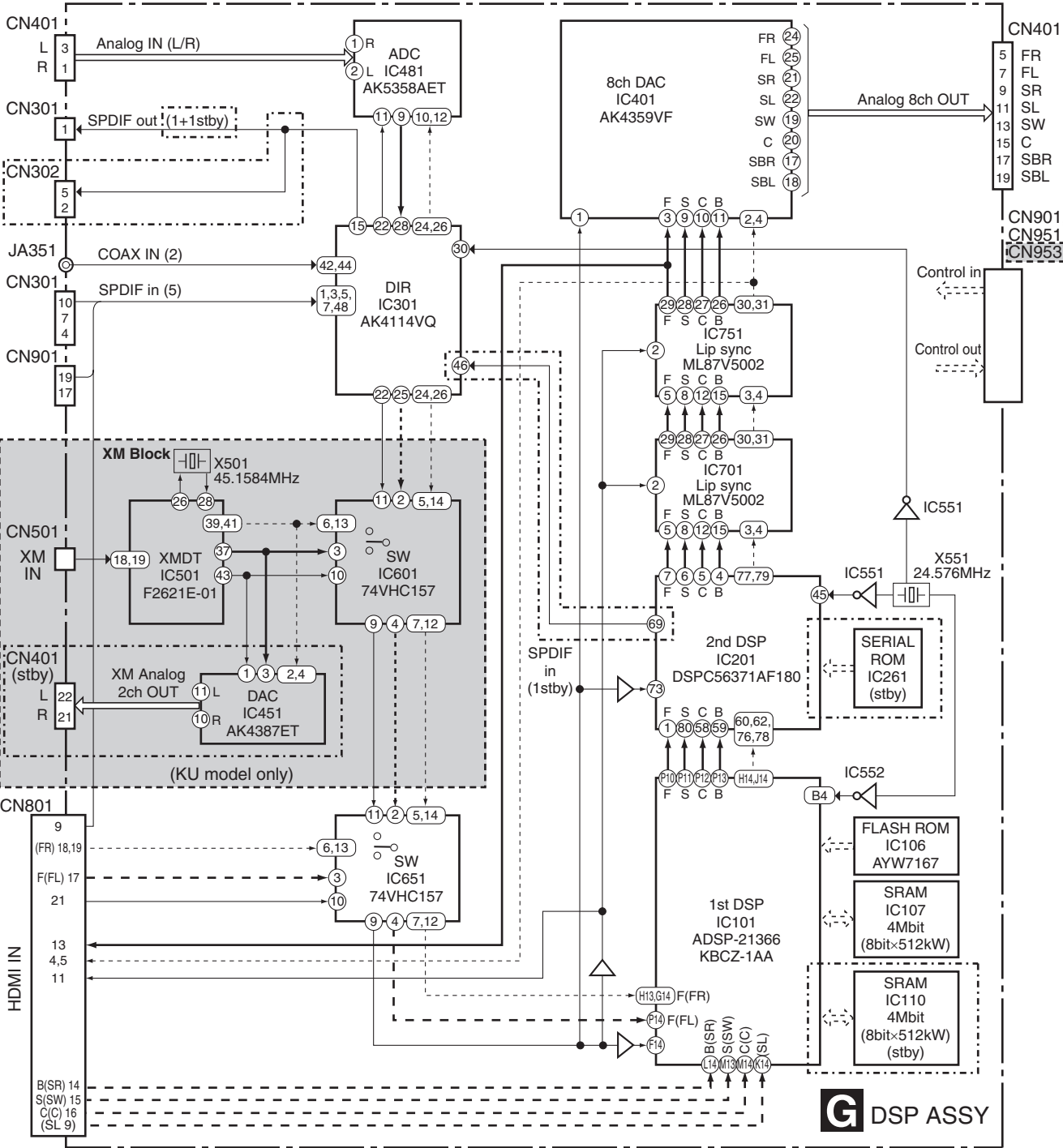

(Supplement) Differences in channel allocation for SACD signal and other signals

CN801		
Pin No.	SACD signal	Other signals
9	Data(SL)	-
14	Data(SR)	Data(SBL,SBR)
15	Data(SW)	Data(SL,SR)
16	Data(C)	Data(C,SW)
17	Data(FL)	Data(FL,FR)
18	Data(FR)	LR clock

IC101		
Pin No.	SACD signal	Other signals
H13	Data(FR)	LR clock
K14	Data(SL)	-
L14	Data(SR)	Data(SBL,SBR)
M13	Data(SW)	Data(SL,SR)
M14	Data(C)	Data(C,SW)
P14	Data(FL)	Data(FL,FR)

### • Power Block and GND Map

• [Dashed Box]: KUXJ and KUXJ/CA types only

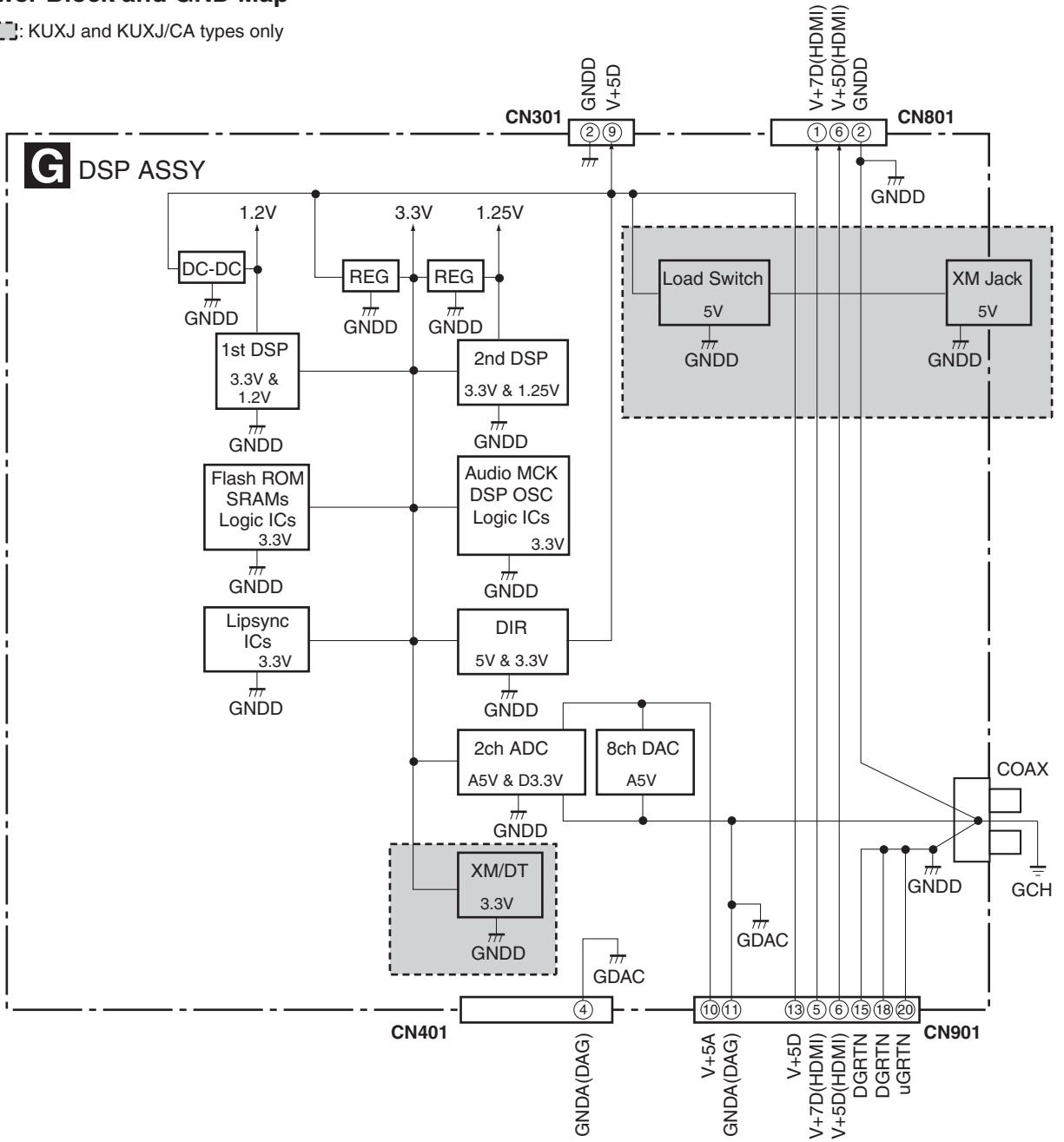

A  
B  
C  
D  
E  
F

• Conditions for selecting SPDIF or I2S output from HDMI Assy.

A

	pcm	fs(kHz)	Layout	SPDIF	I2S(3 lines)	
Indistinguishable	Compression DVD-V	48	2ch	⊙	x	
	Compression *.WAV	44	2ch	○	x	
		48	2ch	○	x	
	dts-CD	44	2ch	○	x	
	PCM	44	2ch	○	x	
		48	2ch	○	x	
	DVD-V	96	2ch		○	
		LPCM	44	2ch	○	
				Multi	x	○
	DVD-A	48	2ch	○		
				Multi	x	○
		88	2ch		○	
				Multi	x	○
		96	2ch		○	
				Multi	x	○
176		2ch	x	○		
			Multi	-	-	
192	2ch	x	○			
		Multi	-	-		

B

C

SACD	2ch	x	○	(DSD)
	Multi	x	○	(DSD)

dts HD Master Audio	x	○
dts HD High Resolution Audio	○	x
dts HD LBR	○	x
Dolby TrueHD	x	○
Dolby Digital Plus	○	x

D

E

F

## 5.1.2 HDMI TROUBLESHOOTING

### HDMI Simple Diagnosis

Please refer to the one point trouble shooting first before checking the flow chart on the next page.

#### HDMI

Symptom	Remedy
The HDMI indicator blinks continuously.	Check all the points below.
No picture or sound.	<ul style="list-style-type: none"> <li>This receiver is HDCP-compatible. Check that the components you are connecting are also HDCP-compatible. If they are not, please connect them using the component, S-video or composite video jacks.</li> <li>Depending on the connected source component, it's possible that it will not work with this receiver (even if it is HDCP-compatible). In this case, connect using the component, S-video or composite video jacks between source and receiver.</li> <li>If the problem still persists when connecting your HDMI component directly to your monitor, please consult the component or monitor manual or contact the manufacturer for support.</li> </ul>
No picture.	<ul style="list-style-type: none"> <li>To see the on-screen display, you must also connect the receiver and TV with a composite, component, or S-video cable.</li> <li>Depending in the output settings of the source component, it may be outputting a video format that can't be displayed. Change the output settings of the source, or connect using the component, S-video or composite jacks.</li> </ul>
No sound, or sound suddenly ceases.	<ul style="list-style-type: none"> <li>Check that the HDMI AV setting is set to <b>AMP/THROUGH</b>.</li> <li>If the component is a DVI device, use a separate connection for the audio.</li> <li>Check the audio output settings of the source component.</li> </ul>
Noisy or distorted picture.	<ul style="list-style-type: none"> <li>If the problem still persists when connecting your HDMI component directly to your monitor, please consult the component or monitor manual or contact the manufacturer for support.</li> </ul>

#### 1. Causes for noncompletion of HDMI authentication between the source equipment and this unit (the HDMI indicator is unlit or flashes)

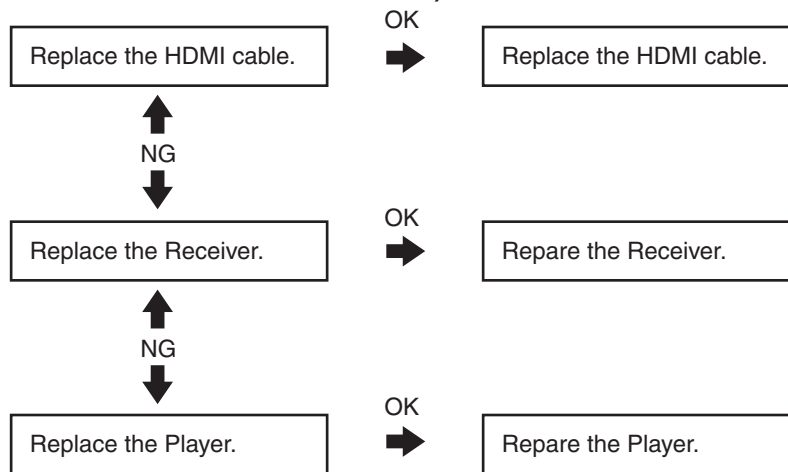

#### 2. Causes for noncompletion of HDMI authentication between the monitor and this unit (no display or sound from the monitor)

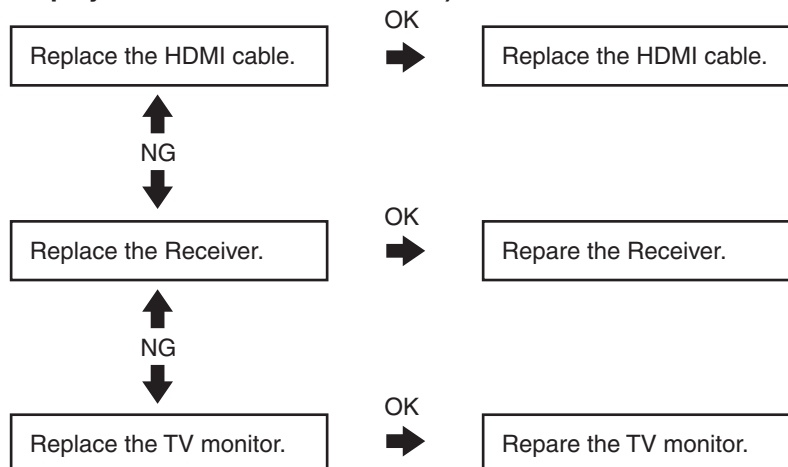

# HDMI Troubleshooting

The parts marked like **V+5** in the following chart are located in "HDMI & DVC Assy Check Points".

## Common section

### Step 1-1: Connections

CN1001, CN1002

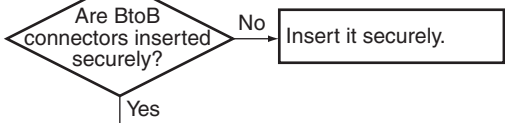

### Step 1-2: Power supply

V+5 5 V **V+5**

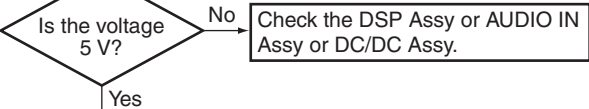

IC901 (Pin 3) 3.3 V **V+3R3VC**

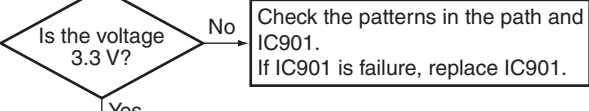

V+3R3UC 3.3 V (HDMI UCOM) **V+3R3UC**

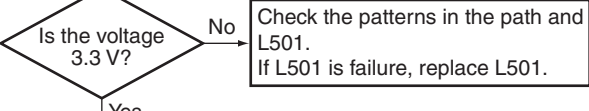

### Step 1-3: Reset

CN1001 (Pin 2) HDRST **O**

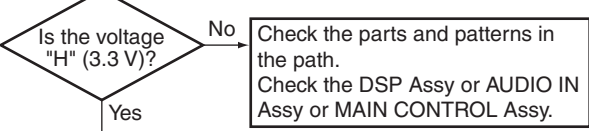

To Step 2-1: HDMI section  
To Step 3-1: Video converter section

## HDMI section

### Step 2-1: Power supply

CN1001 (Pin 26) 7 V **V+7D**

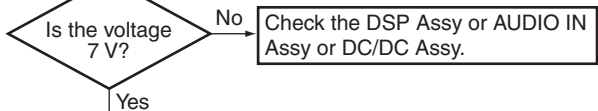

IC911 (Pin 5) 5 V (HDMI OUT) **V+5HD**

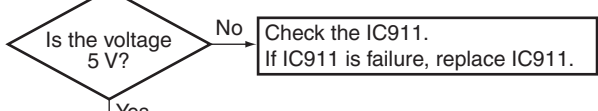

R1002 5 V **V+5D**

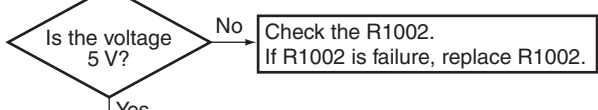

IC151 (Pin 8) 5 V (HDMI IN1) **V+5E0**

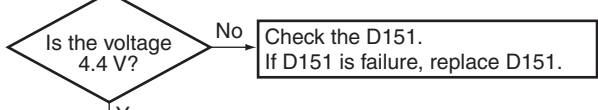

IC171 (Pin 8) 5 V (HDMI IN2) **V+5E1**

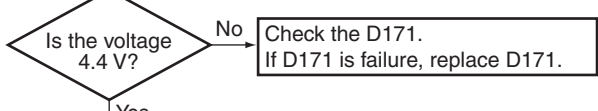

IC501 (Pin 6) PWRCTL1 **A-1**

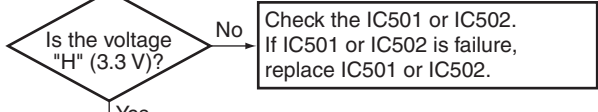

IC501 (Pin 97) PWRCTL2 **A-2**

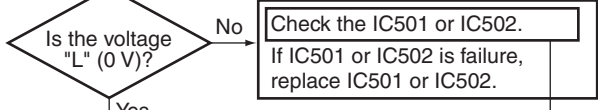

**A**

Check the Q902. If Q902 is failure, replace Q902.

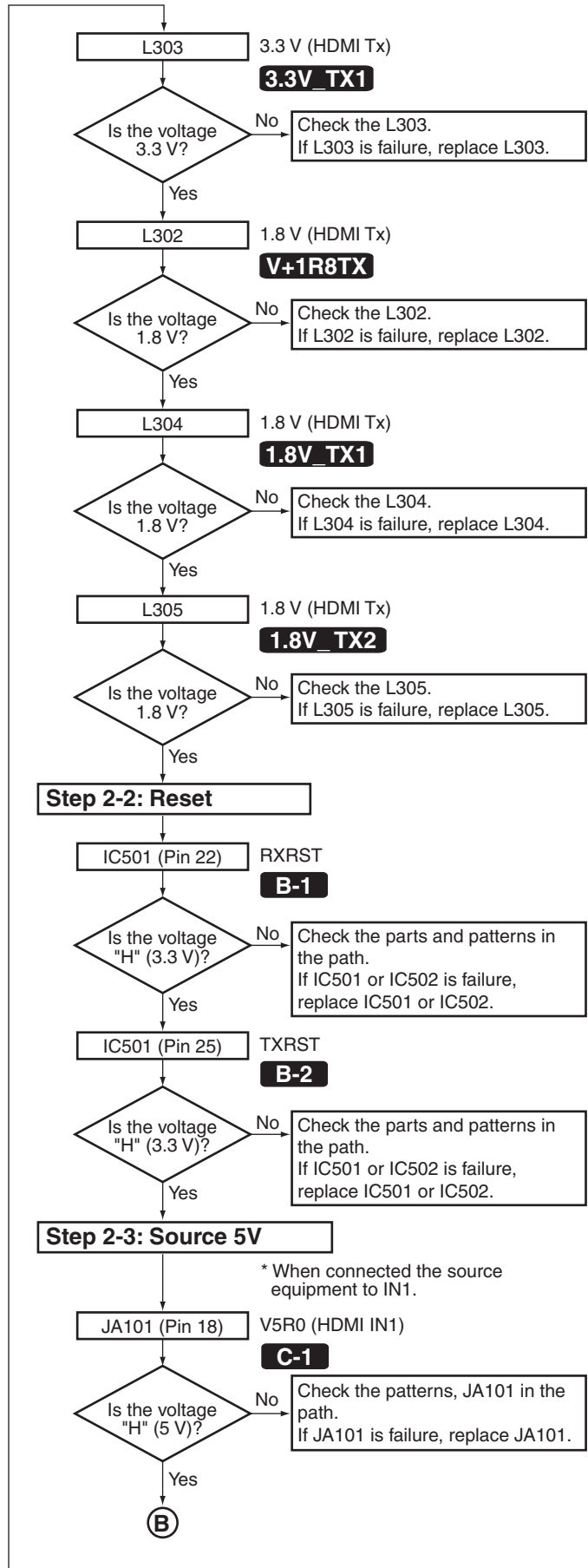
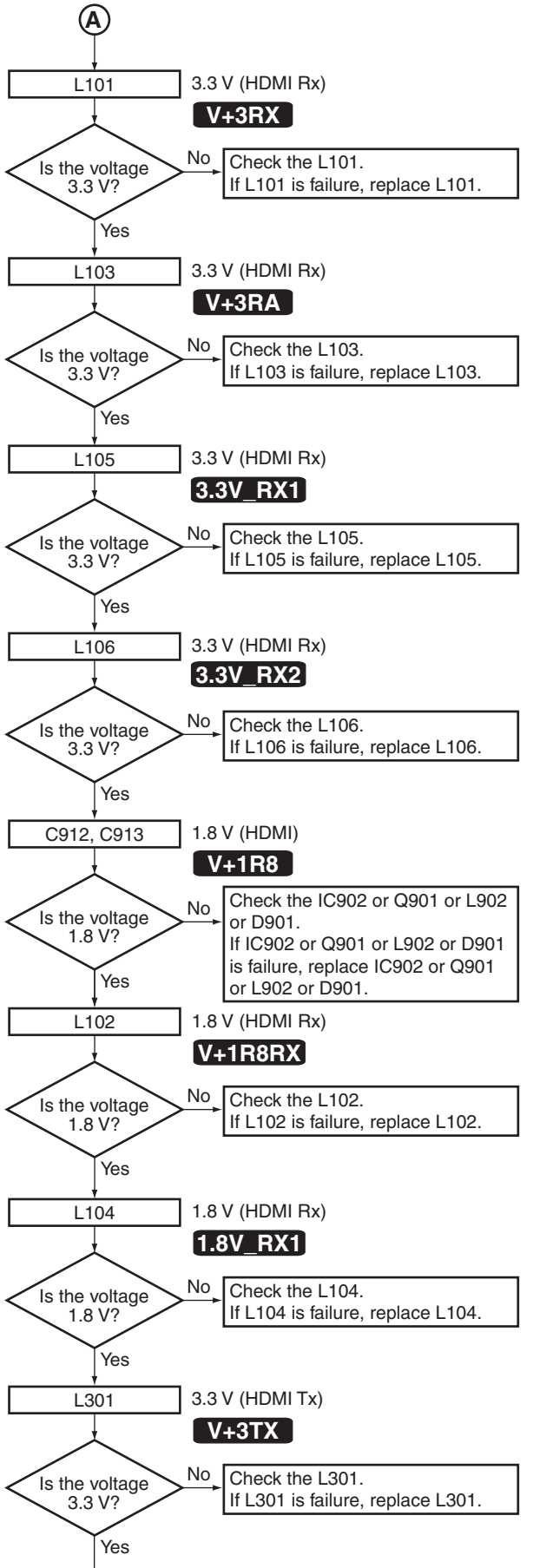

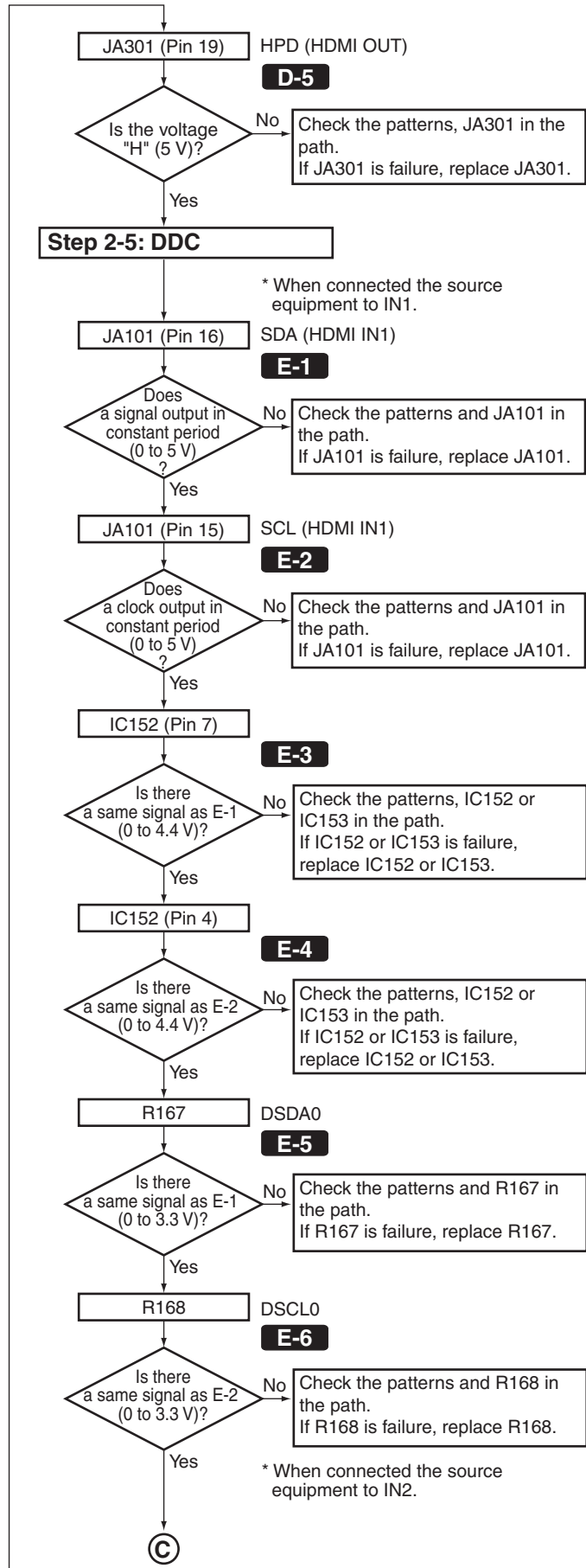
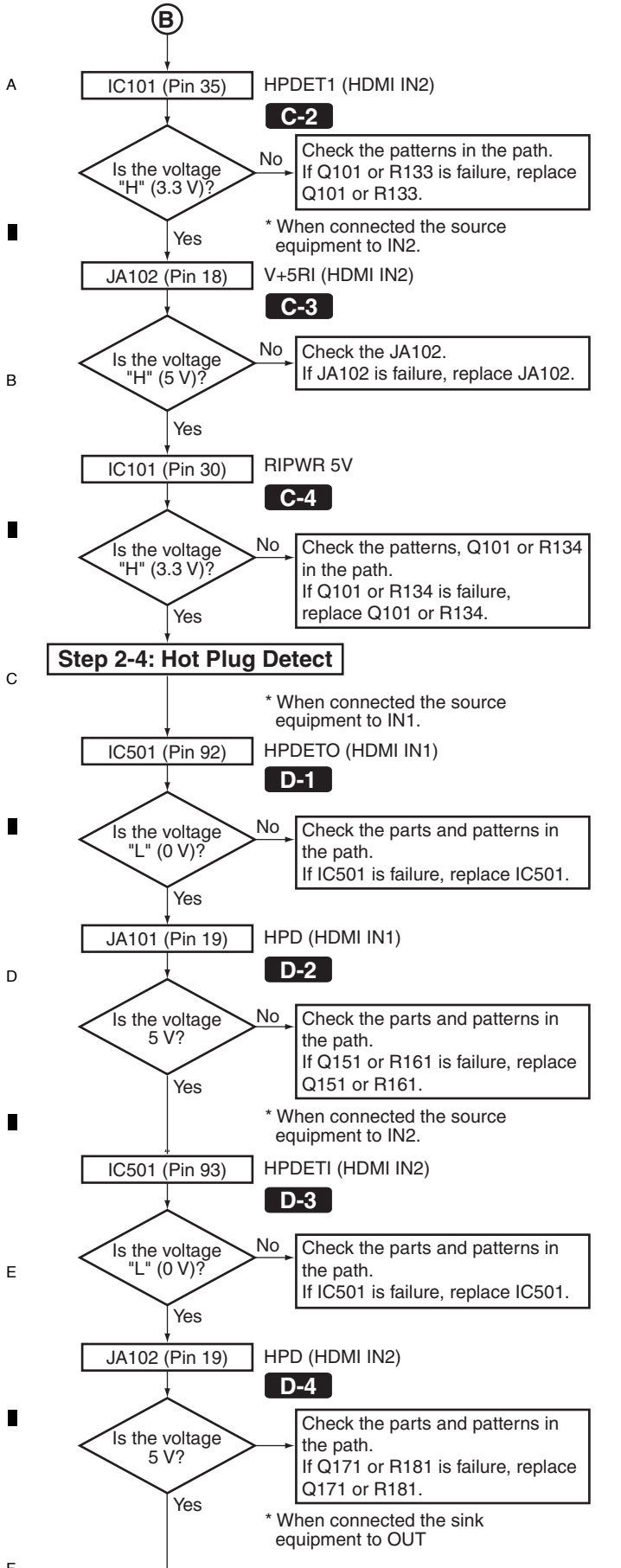

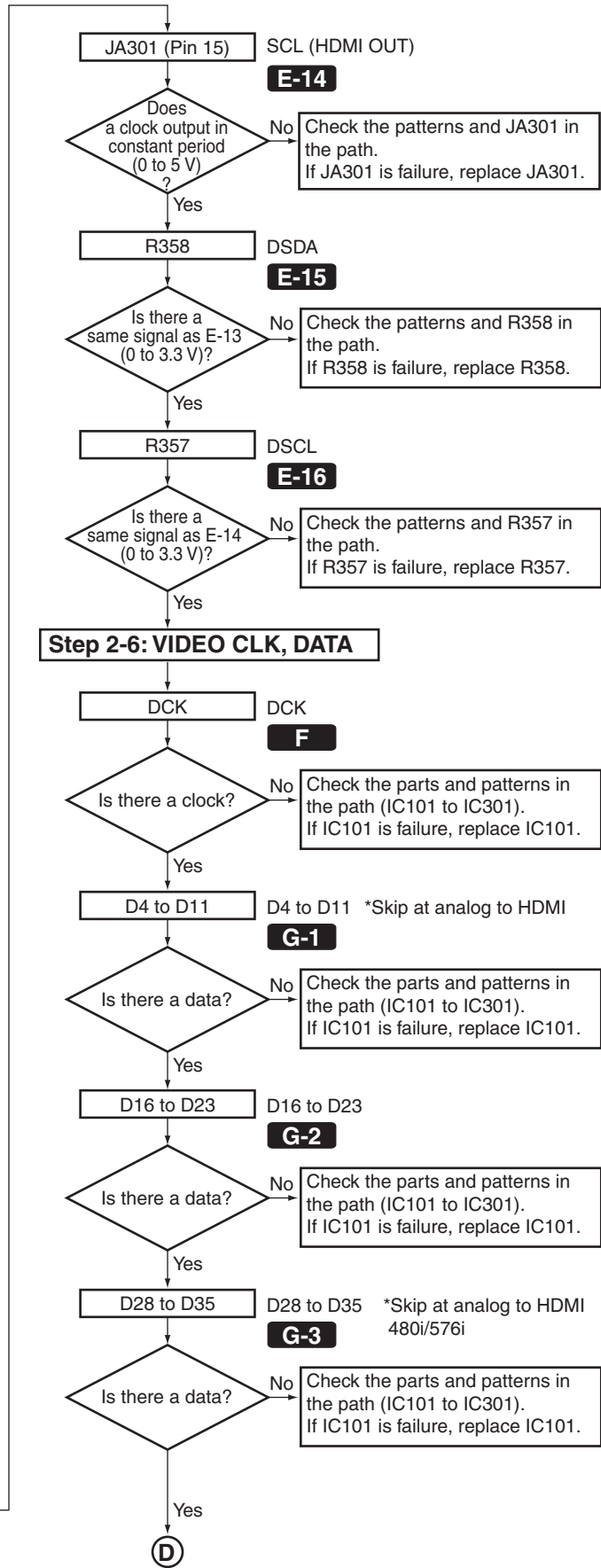
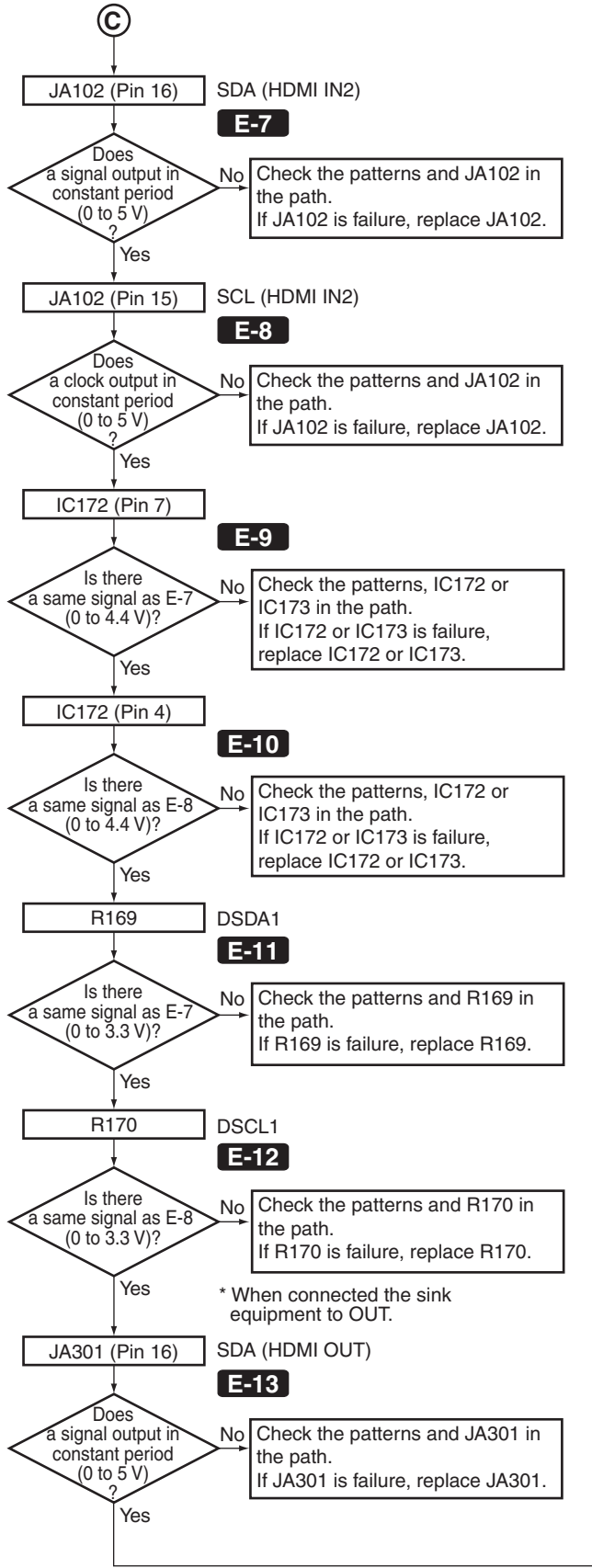

(D)

VSYNC VSYNC

**H-1**

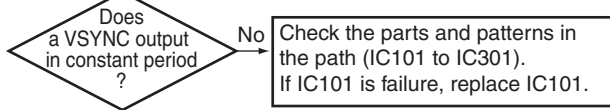

HSYNC HSYNC

**H-2**

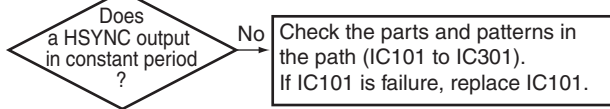

DE DE

**H-3**

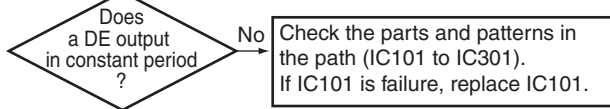

**Step 2-7: AUDIO CLOCK, DATA**

(a): HDMI → HDMI  
(b): ANALOG → HDMI (THROUGH MODE)

(b) CN1001 (Pin 20) MCKI

**O**

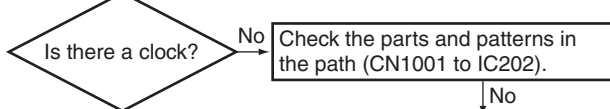

(b) CN1001 (Pin 26) BCKI

**O**

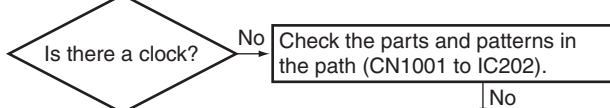

(b) CN1001 (Pin 27) LRCKI

**O**

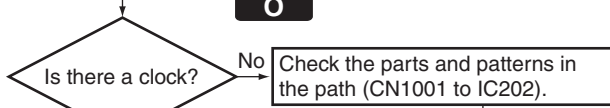

(b) CN1001 (Pin 18) DATAI

**O**

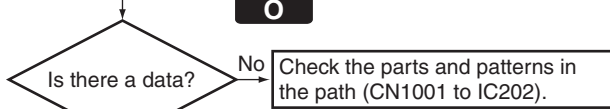

(b) IC202 (Pins 1,4,10,13) XBAOUT

**M-2**

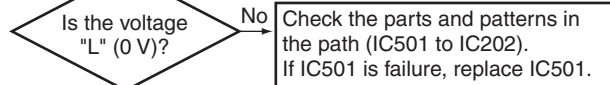

(a)(b) IC201 (Pin 2) MCLK

**I**

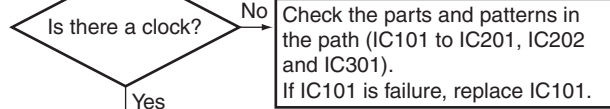

(a) IC201 (Pin 9) SPDIF

**J**

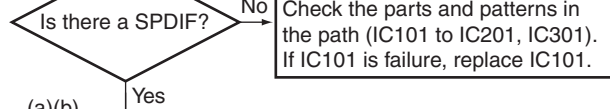

(a)(b) IC201 (Pin 3) SCK(BCK)

**K-1**

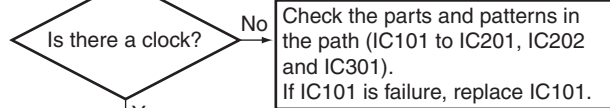

(a)(b) IC201 (Pin 4) WS(LRCK)

**K-2**

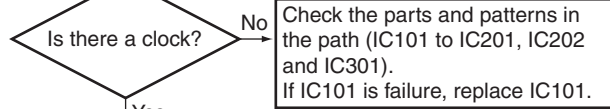

(a)(b) IC201 (Pin 5) SD0(DATA)

**L-1**

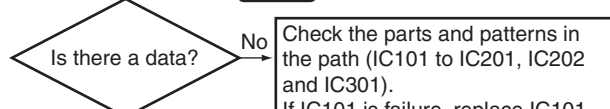

(a) IC201 (Pin 6) SD1(DATA)

**L-2**

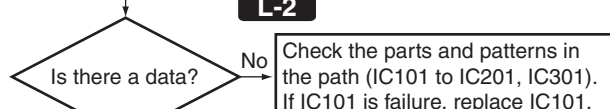

(E)

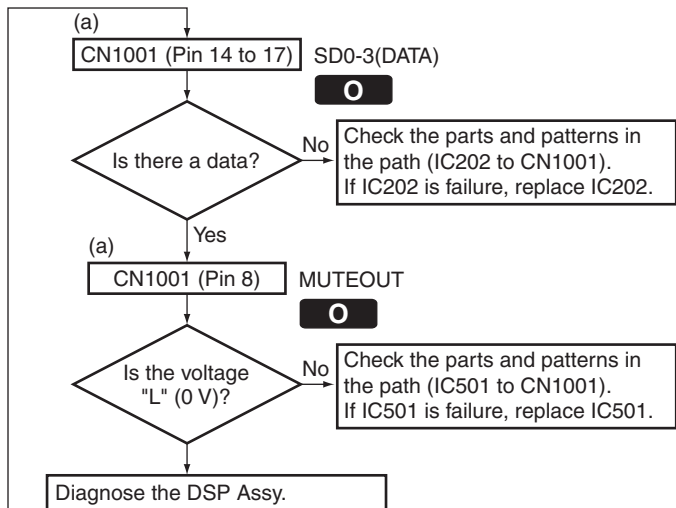
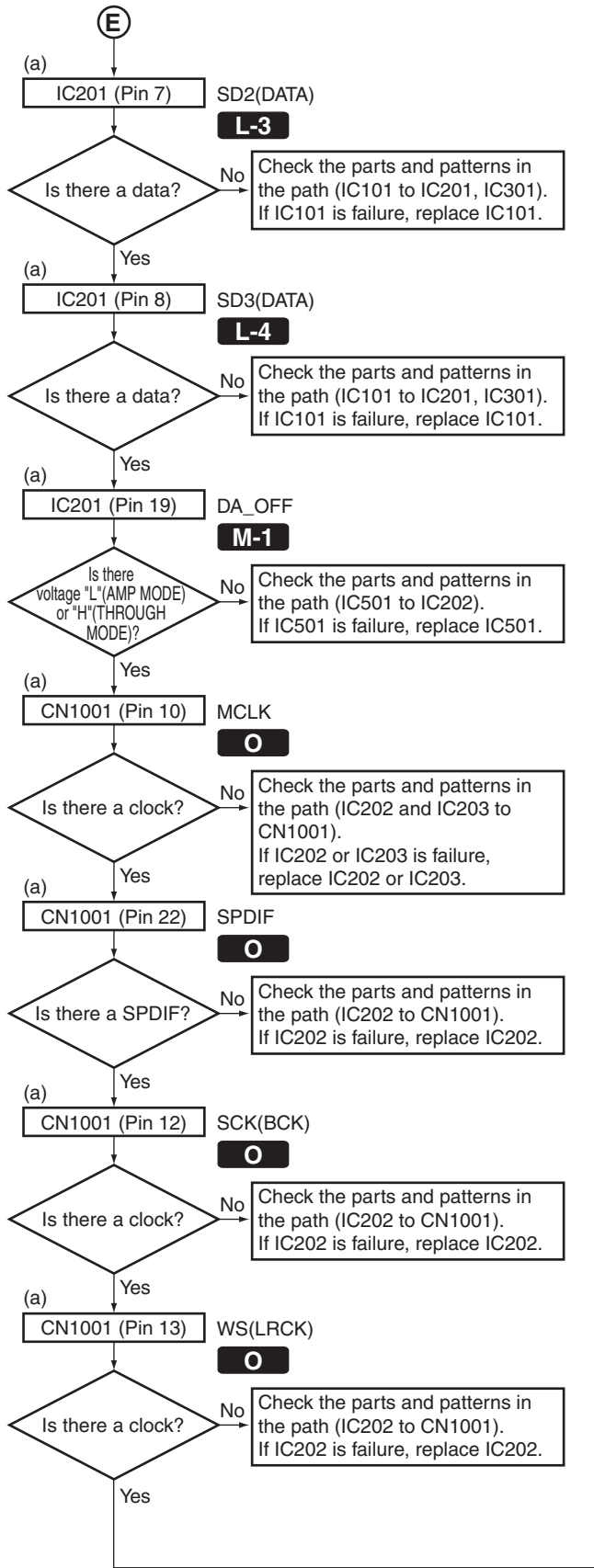

A  
B  
C  
D  
E  
F

### Video converter section

#### Step 3-1: Power Supply

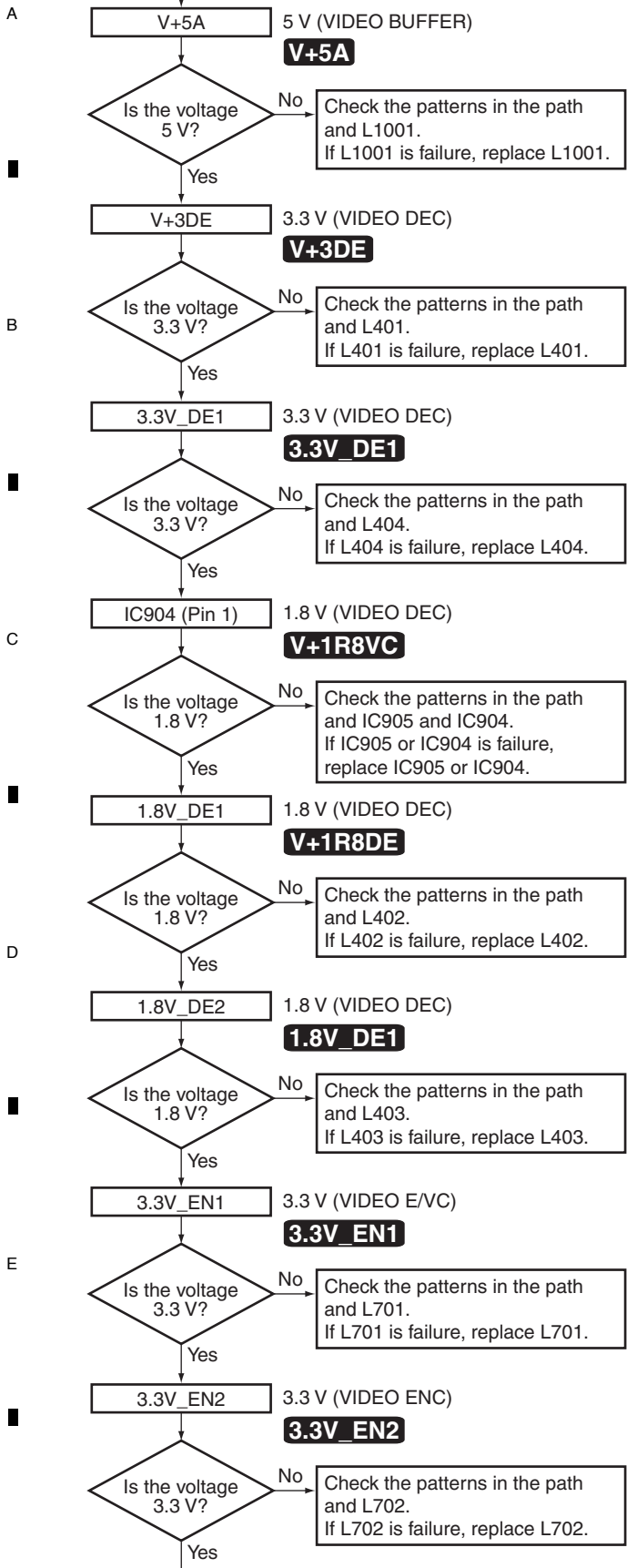

#### Step 3-2: Video Input

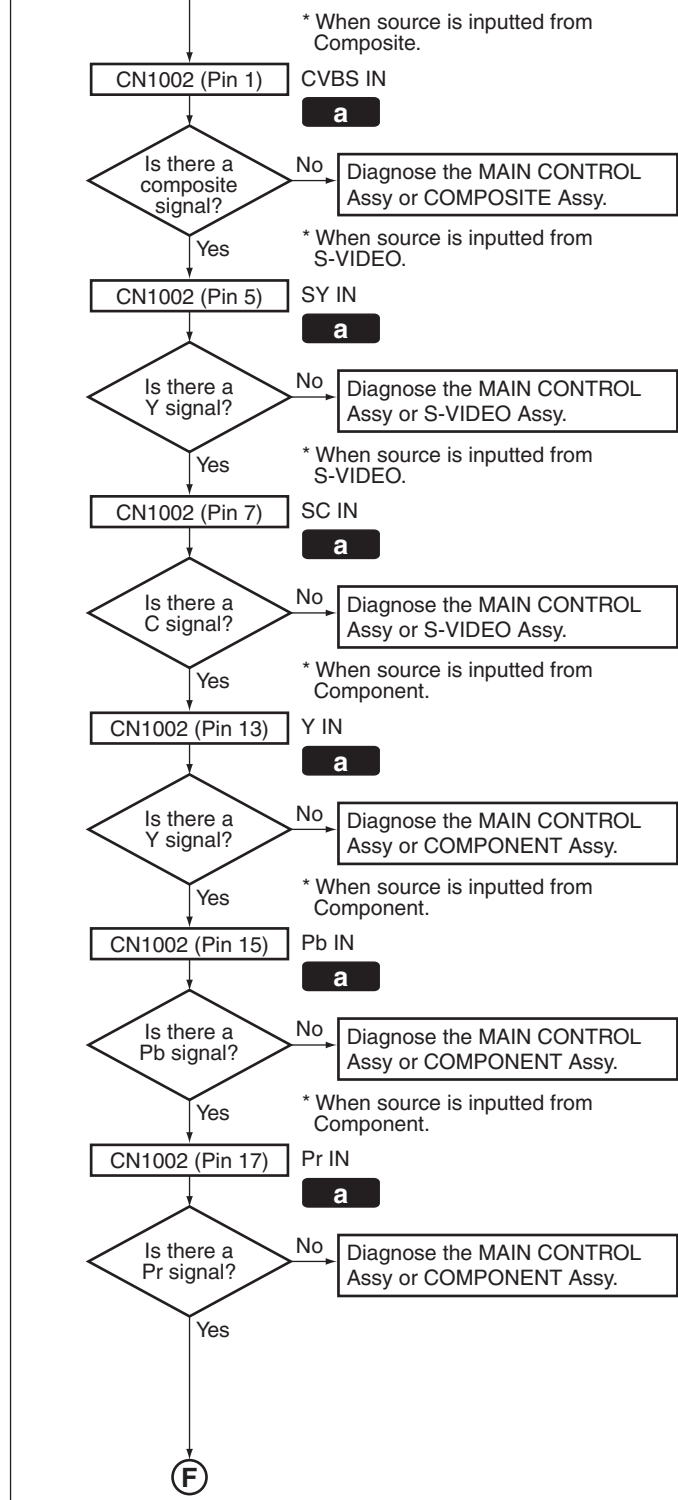

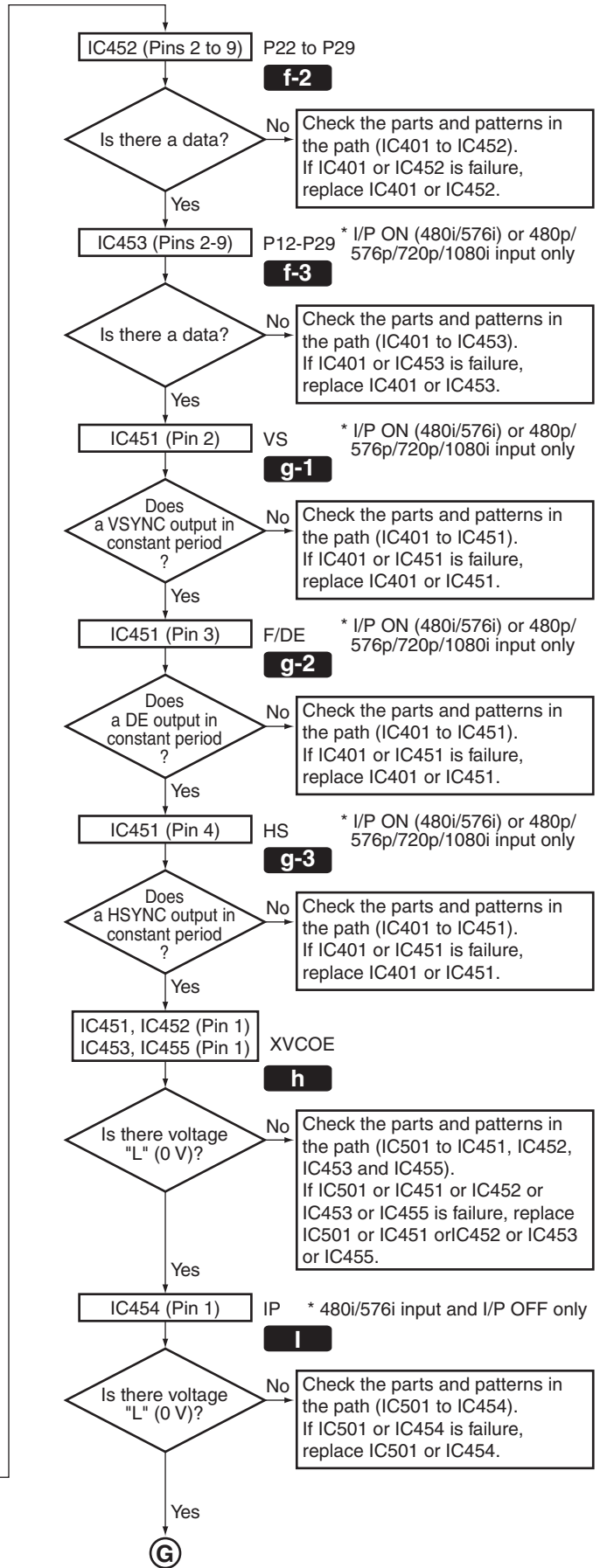
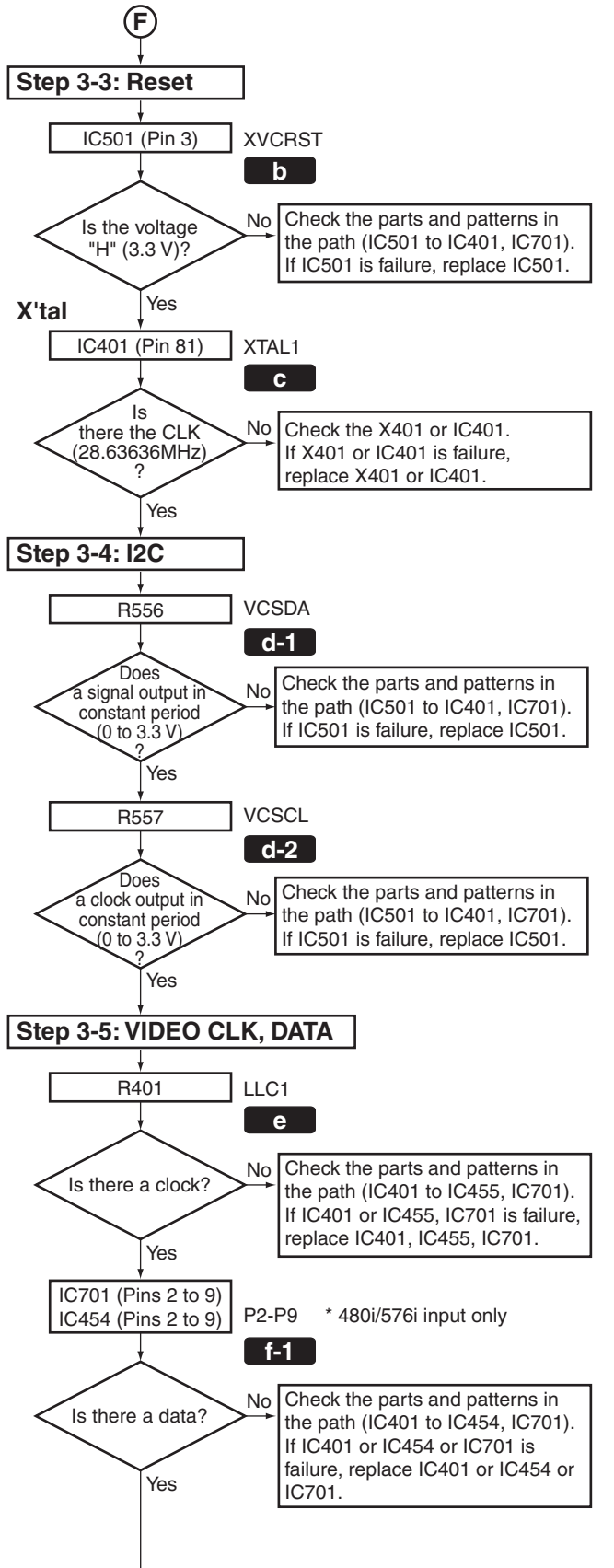



**Step 3-6: Video Output (480i/576i only)**

A

IC701 (Pin 35) DACA

**j-1**

Is there a composite signal?

No Check the parts and patterns in the path (IC701 to R731, Q731). If IC701 or R731 or R732 or Q731 is failure, replace it.

Yes

CN1002 (Pin 3) CVBS OUT

**a**

Is there a composite signal?

No Check the parts and patterns in the path (Q731 to CN1002). If Q731 or R733 is failure, replace Q731 or R733.

Yes

Diagnose the MAIN CONTROL Assy or COMPOSITE Assy.

B

IC701 (Pin 28) DACD

**j-4**

Is there a C signal?

No Check the parts and patterns in the path (IC701 to R761, Q761). If IC701 or R761 or R762 or Q761 is failure, replace it.

Yes

CN1002 (Pin 19) Y OUT

**a**

Is there a Y signal?

No Check the parts and patterns in the path (Q761 to CN1002). If Q761 or R763 is failure, replace Q761 or R763.

Yes

Diagnose the MAIN CONTROL Assy or COMPONENT Assy.

C

IC701 (Pin 33) DACB

**j-2**

Is there a Y signal?

No Check the parts and patterns in the path (IC701 to R741, Q741). If IC701 or R741 or R742 or Q741 is failure, replace it.

Yes

CN1002 (Pin 9) SY OUT

**a**

Is there a Y signal?

No Check the parts and patterns in the path (Q741 to CN1002). If Q741 or R743 is failure, replace Q741 or R743.

Yes

Diagnose the MAIN CONTROL Assy or S-VIDEO Assy.

D

IC701 (Pin 25) DACE

**j-5**

Is there a Pb signal?

No Check the parts and patterns in the path (IC701 to R771, Q771). If IC701 or R771 or R772 or Q771 is failure, replace it.

Yes

CN1002 (Pin 21) Pb OUT

**a**

Is there a Pb signal?

No Check the parts and patterns in the path (Q771 to CN1002). If Q771 or R773 is failure, replace Q771 or R773.

Yes

Diagnose the MAIN CONTROL Assy or COMPONENT Assy.

E

IC701 (Pin 29) DACC

**j-3**

Is there a C signal?

No Check the parts and patterns in the path (IC701 to R751, Q751). If IC701 or R751 or R752 or Q751 is failure, replace it.

Yes

CN1002 (Pin 11) SC OUT

**a**

Is there a C signal?

No Check the parts and patterns in the path (Q751 to CN1002). If Q751 or R753 is failure, replace Q751 or R753.

Yes

Diagnose the MAIN CONTROL Assy or S-VIDEO Assy.

F

IC701 (Pin 24) DACF

**j-6**

Is there a Pr signal?

No Check the parts and patterns in the path (IC701 to R781, Q781). If IC701 or R781 or R782 or Q781 is failure, replace it.

Yes

CN1002 (Pin 23) Pr OUT

**a**

Is there a Pr signal?

No Check the parts and patterns in the path (Q781 to CN1002). If Q781 or R783 is failure, replace Q781 or R783.

Yes

Diagnose the MAIN CONTROL Assy or COMPONENT Assy.

# HDMI & DVC Assy Check Points (Power supply section)

**AK** HDMI & DVC ASSY

SIDE B

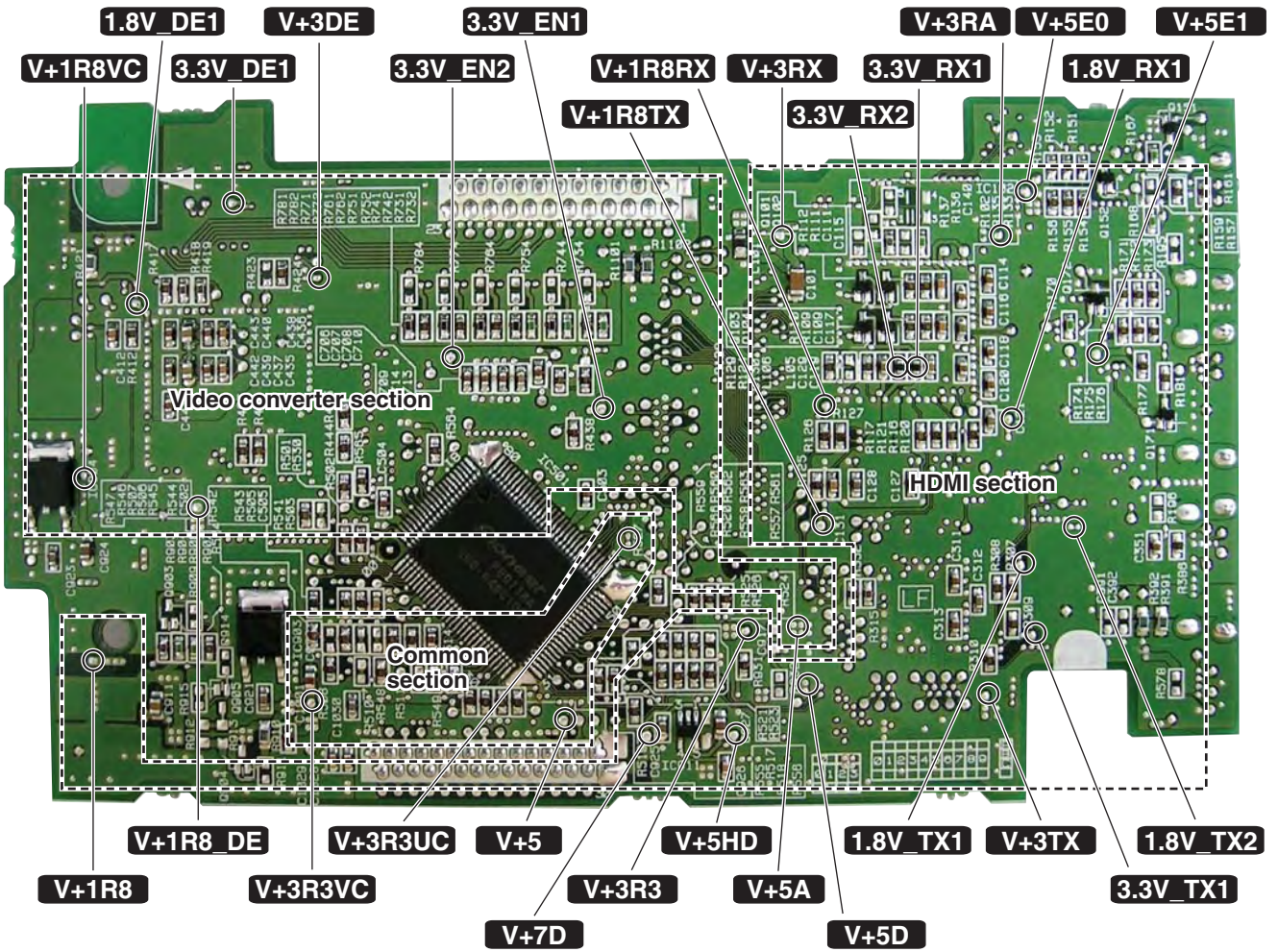

# HDMI & DVC Assy Check Points (Signal section)

A

SIDE B

**AK** HDMI & DVC ASSY

HDMI section

Video converter section

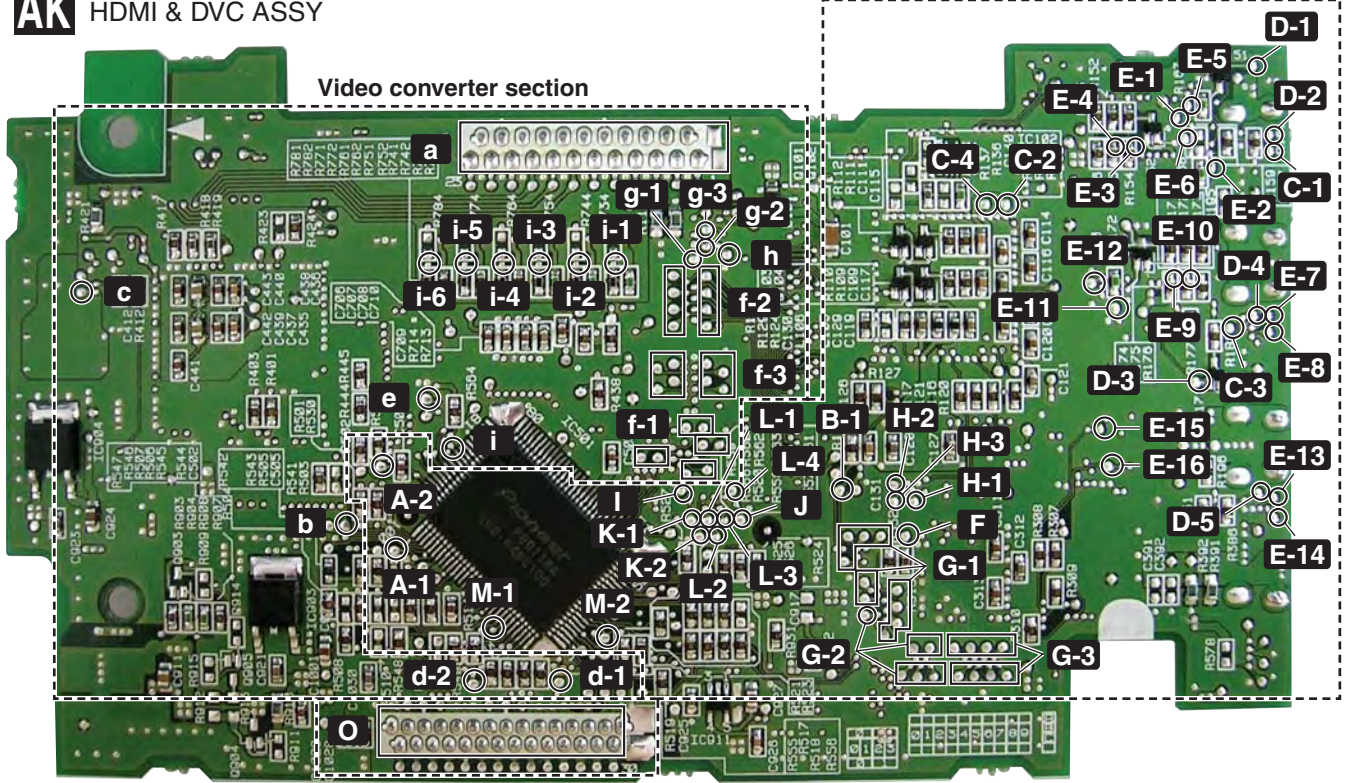

Common section

B

C

D

E

F

# HDMI&DVC ASSY Block Diagram

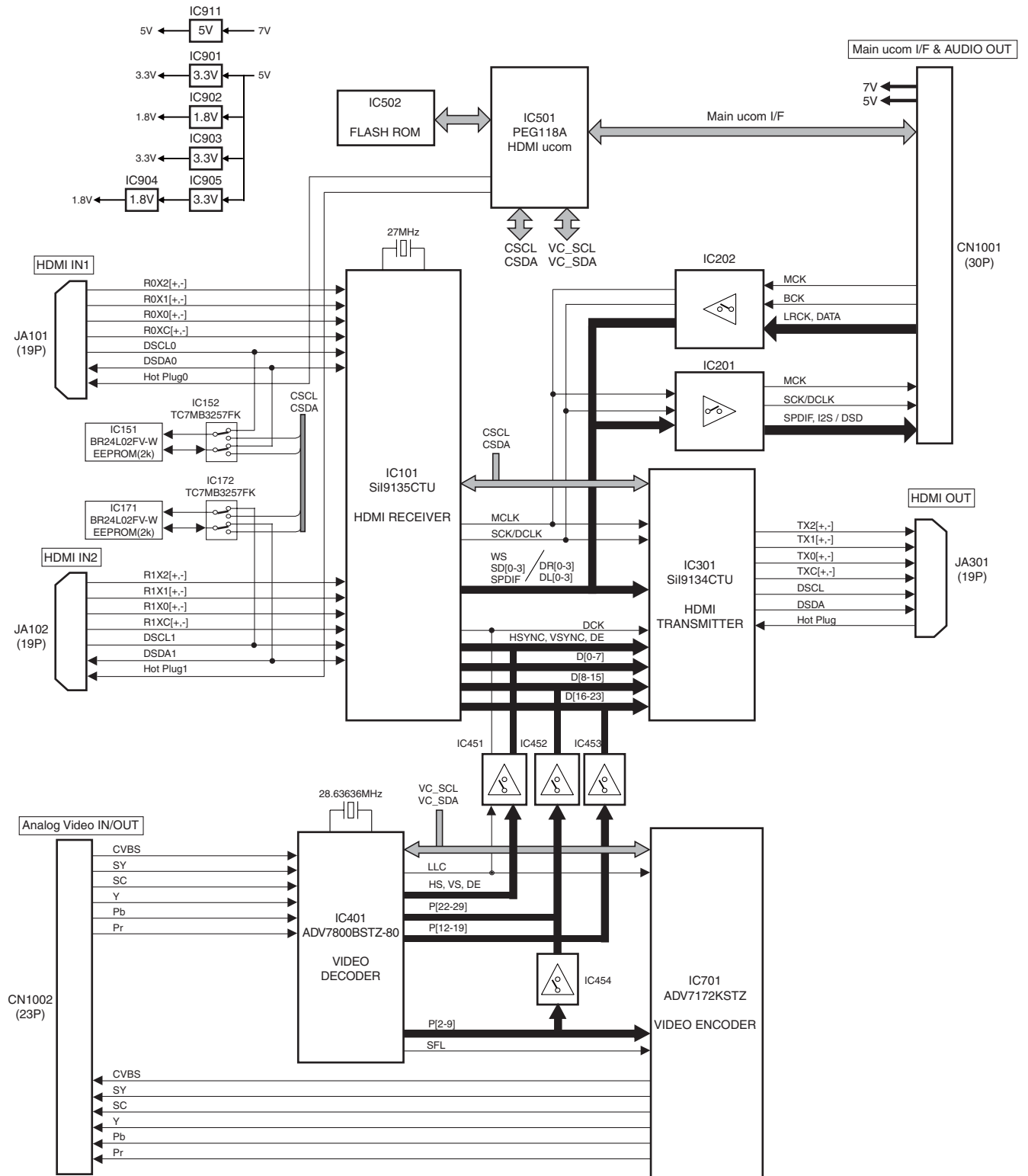

A  
B  
C  
D  
E  
F

## 5.1.3 USB MODULE (VSX-LX50 Only)

### Description of Error Indications

FL Display	Error Content	Possible causes and actions to be taken
USB ERROR1	Detection of overcurrent to a USB device	Overcurrent (500 mA or more) is consumed at the connected USB device. <ul style="list-style-type: none"> <li>Some USB devices, such as a portable HDD, need more current than that this unit supplies. (Use the AC adaptor for the connected USB device.)</li> <li>The USB power is short-circuited.</li> </ul>
USB ERROR2	Detection of a medium not supported	A USB device that this unit does not support (other than the Mass Storage Class) is connected (such as a mouse, printer, or digital camera). <ul style="list-style-type: none"> <li>Connect a mass storage class USB device.</li> </ul>
USB ERROR3	Communication error with the system microcomputer	Communication between TCC8600-00X-EA-UG (IC701) and PEG378A (IC101) failed. <ul style="list-style-type: none"> <li>Defective connection (connectors) inside this unit</li> <li>See STEP 3 of Troubleshooting.</li> </ul>

#### Operations when overcurrent to a USB device is detected

- Overcurrent to a USB device is detected at the port for the microcomputer.
- The power supply to the USB device is stopped.
- Control of 5 V power is disabled at the port for the microcomputer.
- Change of indications on the FL display

Flashes for 2 sec.

U:S:B: E:R:R:1



Lights up after flashing for 2 sec.

U:S:B: E:R:R:1

- To supply power to the USB module again:

- Turn the power to the unit off then back on.
- Set the function setting to anything other than USB then back to USB.
- Press the USB play key on the remote control unit.

- After overcurrent is detected, if the USB play key is pressed while the error indication is displayed, power supply to the USB module is restored. If overcurrent is no longer detected, the indications shown below are displayed (normal indication):

U:S:B:

In this state, flashing of "USB ERROR1" stops, but playback will not start. To start playback, press the USB play key again.

In the above case, if overcurrent is detected again, the above procedures 1 through 4 are repeated.

#### In a case where a medium not supported is connected

- Change of indications on the FL displays

Flashes for 2 sec.

U:S:B: E:R:R:2



Lights up after flashing for 2 sec.

U:S:B: E:R:R:2

If overcurrent is detected before detection of a non-supported medium, the error indication "USB ERROR1" remains, as the power supply to the USB module is stopped.

#### On supported media

The formats of supported media that can be played back on this unit are MP3, WMA, and AAC.

Some media in MPEG4 can also be played back. As AAC derives from MPEG4 codec, playback of media in AAC codec of MPEG4 is possible.

## ■ Block Diagram of the USB Assy

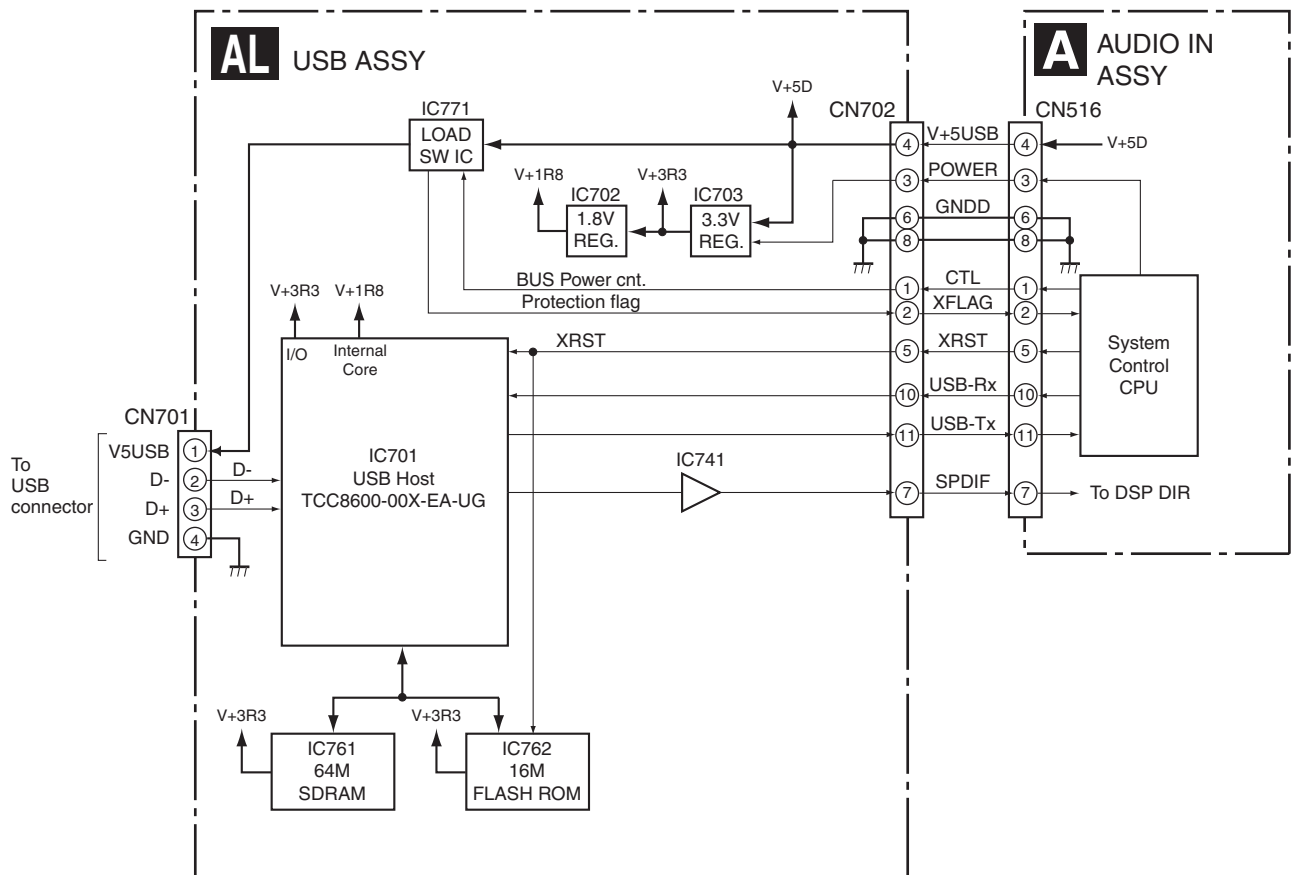

Main parts	Purpose
<b>TCC8600-00X-EA-UG</b>	: USB Host control decoder (MP3/WMA/MPEG-4AAC)
<b>16M FLASH ROM</b>	: Firmware is stored
<b>64M SDRAM</b>	: Temporary storage area of decoding music file
<b>LOAD SWITCH</b>	: Current limitation to USB device power

# USB Troubleshooting

## Step 1: Connectors

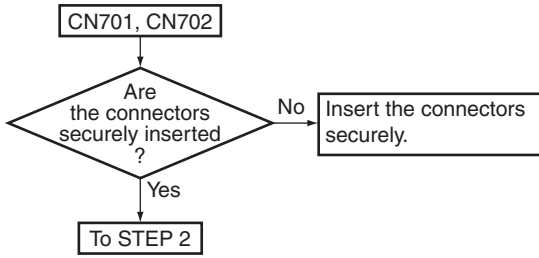

## Step 2: Power supply

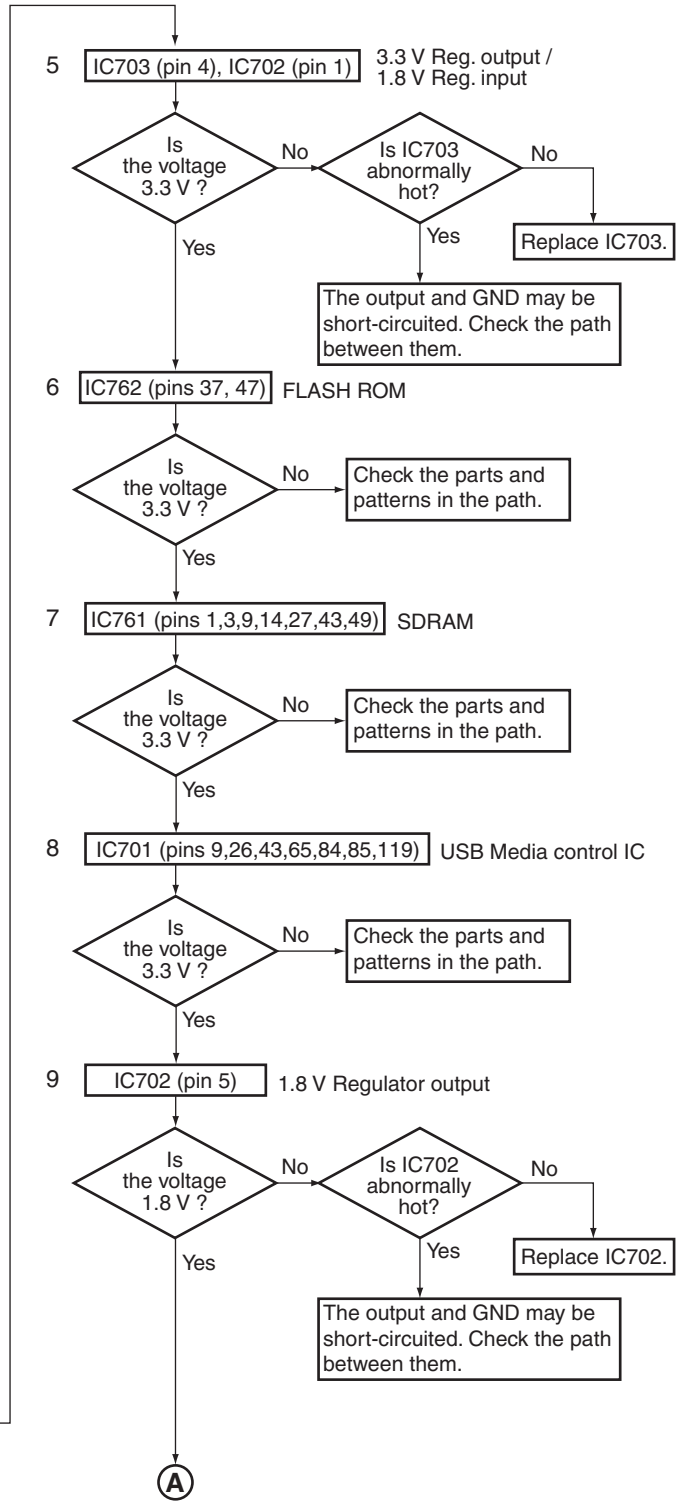
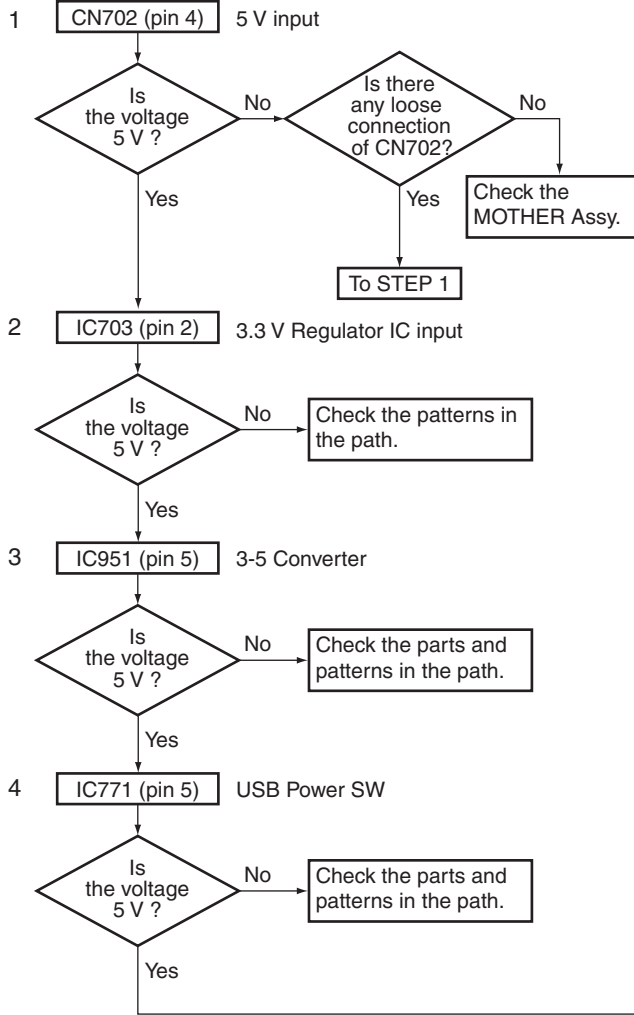

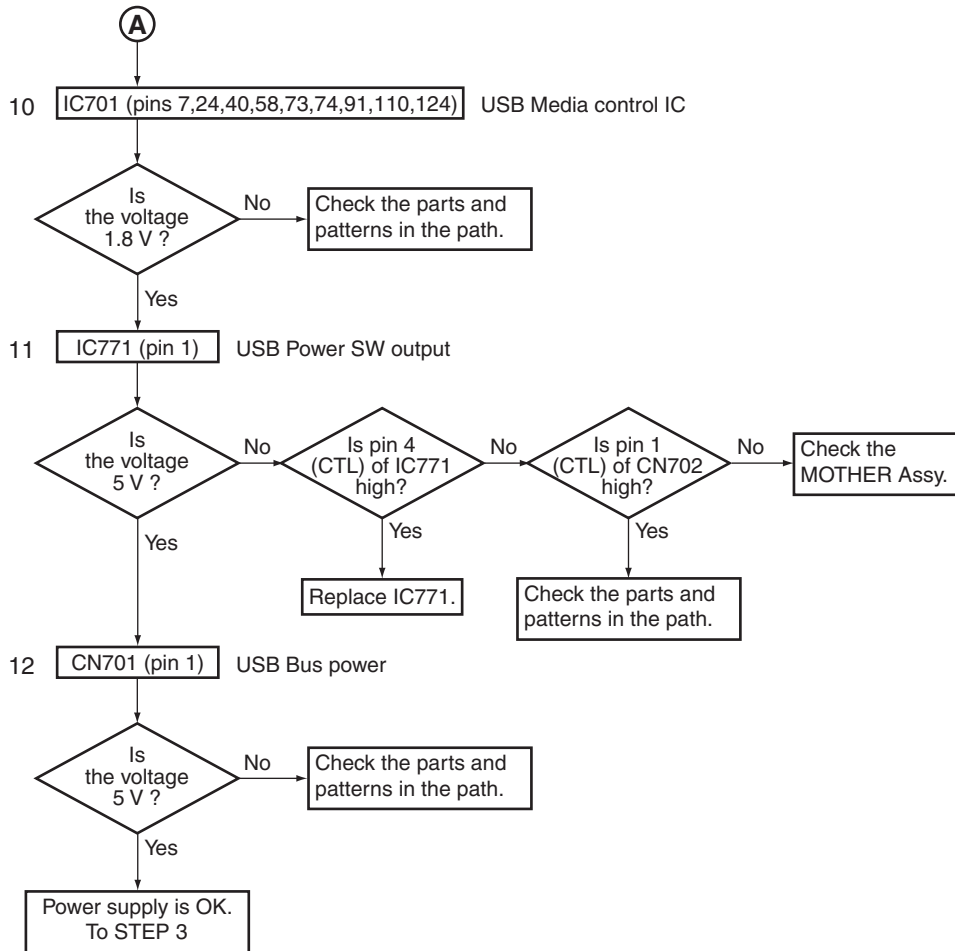

**Step 3: Operation of USB Media control IC**

**Note:** Please confirm it with the USB memory connected for the content.

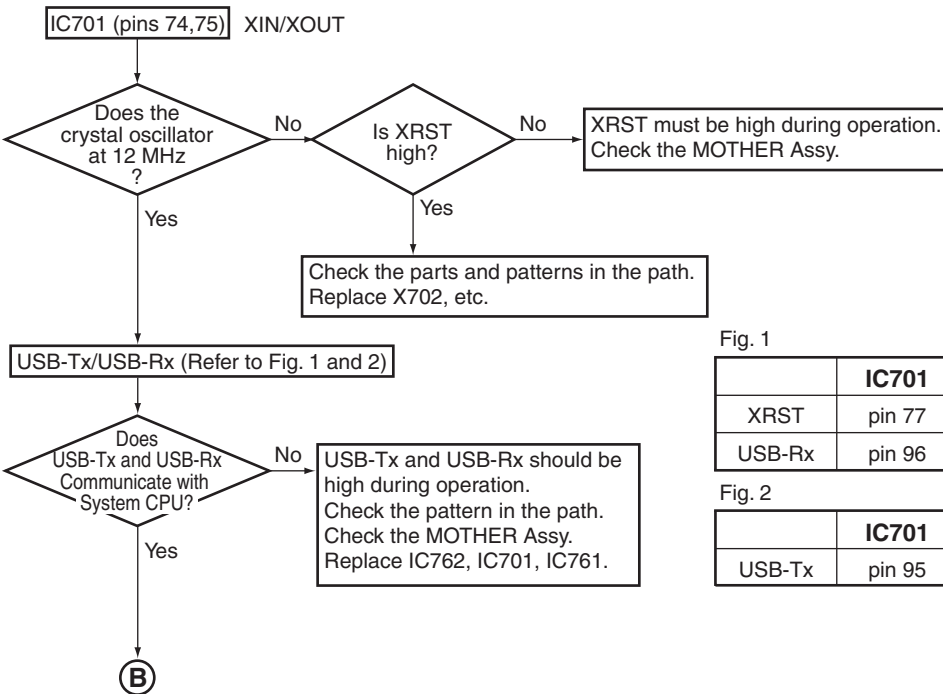

Fig. 1

	IC701		CN702
XRST	pin 77	R951	pin 5
USB-Rx	pin 96	R955	pin 10

Fig. 2

	IC701	IC951 (3 V → 5 V)	CN702
USB-Tx	pin 95	pin 2	pin 4
			pin 11

(B)

Yes

CN701 (pins 2,3) D+/D-

Are there the waveforms like figure?

No

D+ and D- should have waveform during normal condition. Check the pattern in the path. Check the MOTHER Assy.

Yes

Operation of IC701 is OK. To STEP 4

Fig. D+

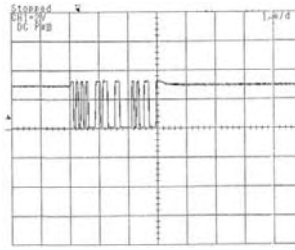

X: 1 μsec/div, Y: 2 V/div

Fig. D-

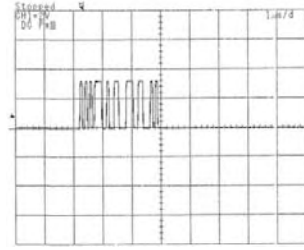

X: 1 μsec/div, Y: 2 V/div

Step 4: Audio Out check

IC701 (pin 105) SPDIF

Is there a SPDIF signal?

No

Check the output from IC701 (pin 105).

Yes

IC741 (pin 2) SPDIF

Is there a SPDIF signal?

No

Check the output from IC701 (pin 105).

Yes

IC741 (pin 4) SPDIF

Are there audio signal?

No

Replace IC741.

Yes

Check the parts and pattern between IC701 and CN702.

## 5.1.4 SIRIUS BLOCK TROUBLESHOOTING (VSX-91TXH/VSX-9120TXH Only)

### Step 1 : Connectors

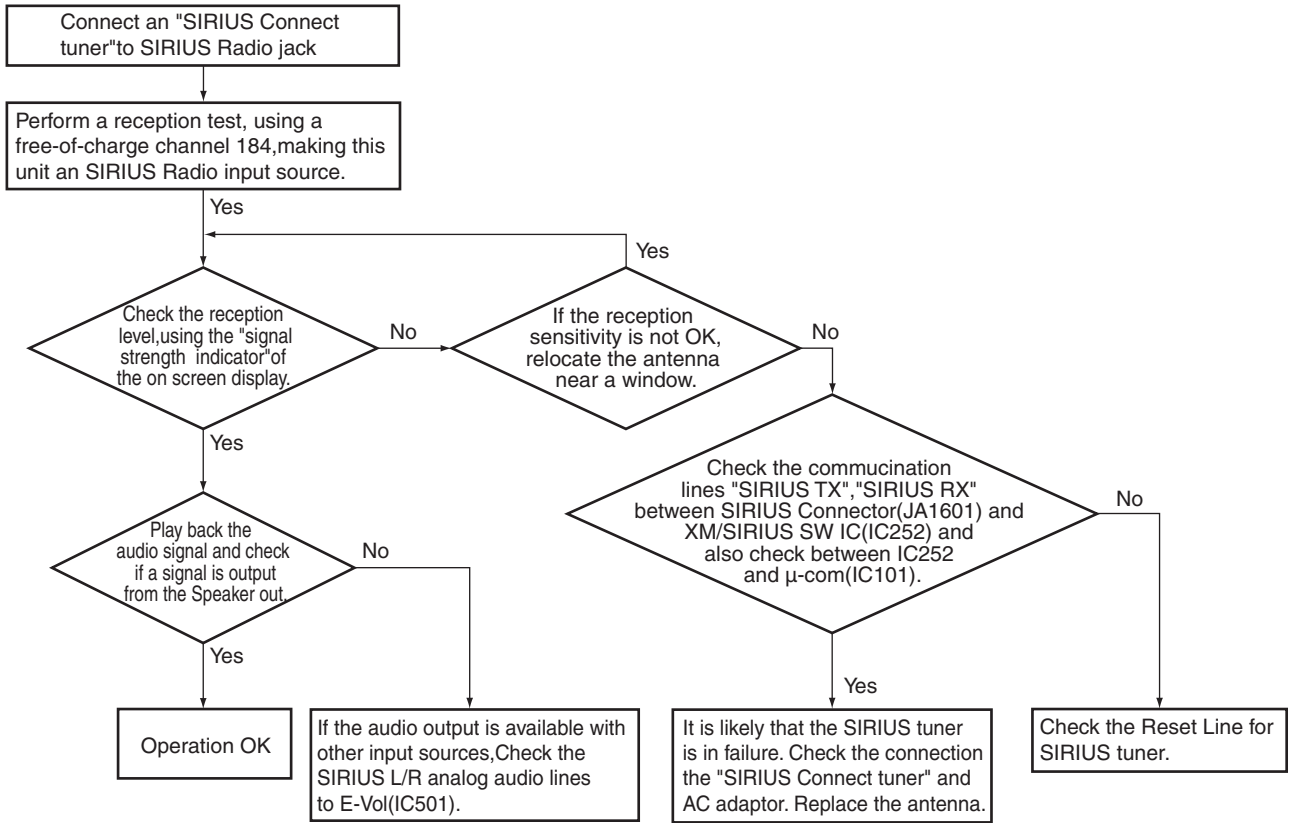

# 5.2 CIRCUIT DESCRIPTION

## 5.2.1 PROTECTION CIRCUIT SPECIFICATION

### ● Protection Circuit Process List

Item	Purpose	Detection Method	Process	Warning Indication	Remarks
DC detection	To detect amplifier damage (defect status) A process to protect speakers (for protection of connected external devices)	Detects when the DC_PROTECT port becomes "L". (Pin 87 of IC101)	Turns muting on and speaker relay off, then turns off the power after 3 seconds. Then flashes MCACC indicator.	Flashing "AMP ERR" for 3 seconds.	Once detected and turned the power off, input a key never again. If the DC_DET port becomes "H" within 3 seconds, the unit returns to normal condition automatically.
AMP overload	To detect overloading (abnormal status) With low-load driving or a short circuit of the speaker terminals (for protection of the amplifier)	Detects when the OL_DET port becomes "L" (checks by interrupt). (Pin 19 of IC101)	Turns muting on and speaker relay off, and immediately turns off the power. Then flashes PHASE CONTROL indicator.	None	
Overheat detection	Self reset type protection feature by temperature-rise of heat sink	Detects when the TEMP2 port becomes "H". (Pin 44 of IC2301)	Turns muting on and speaker relay off, then turns off the power after 3 seconds.	Flashing "OVERHEAT" for 3 seconds.	If the TEMP2 port becomes "L" within 3 seconds, the unit returns to normal condition automatically.
12V trigger failure detection	To detect the shortcircuit of 12V trigger output (load more than 50mA) (for protection of the amplifier)	Detects when the 12VDET port becomes "H". (Pin 44 of IC2301)	Turns 12V trigger output to off.	Flashing "12V TRG ERR"	Continue showing warning. Release the FL indication by switching the INPUT SEL or the turns the power off.

### ● DC Detection Circuit

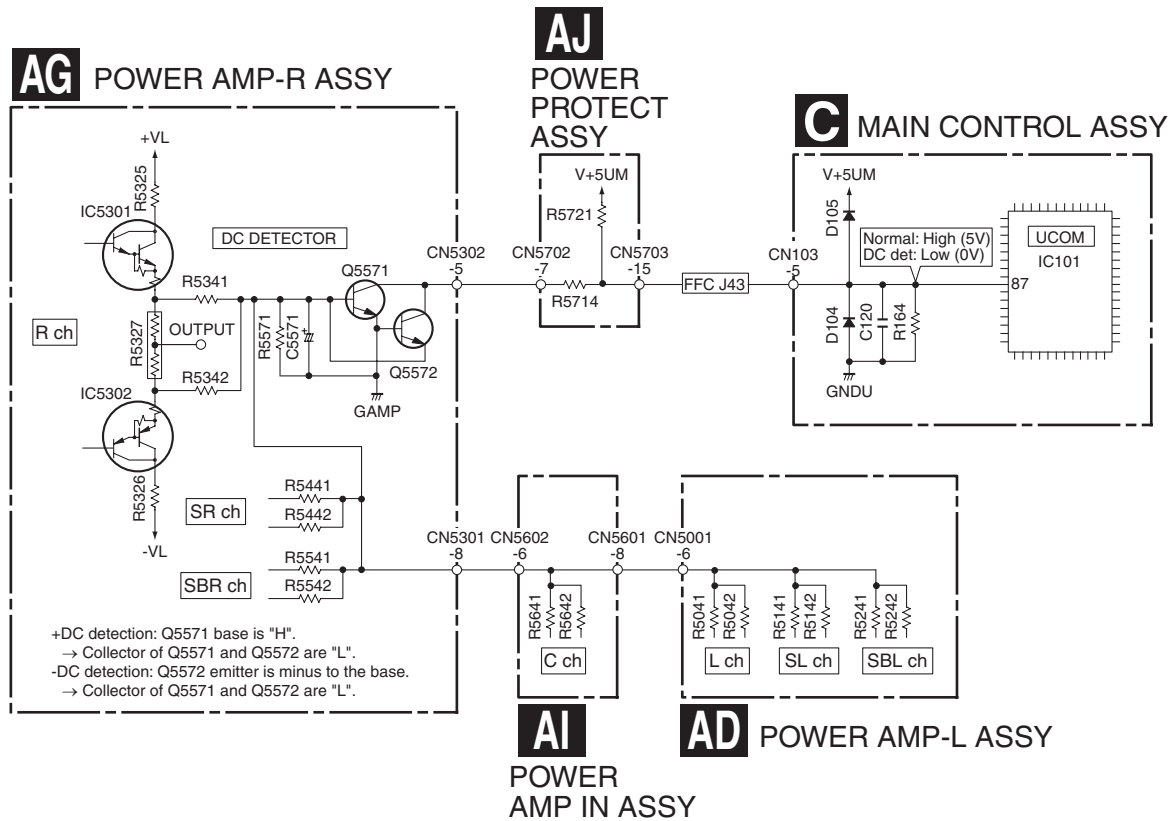

# ● OL (Over Load) Detection Circuit

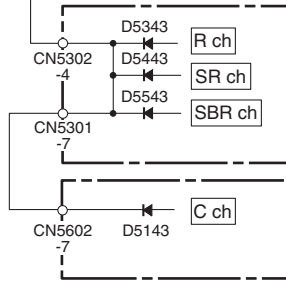
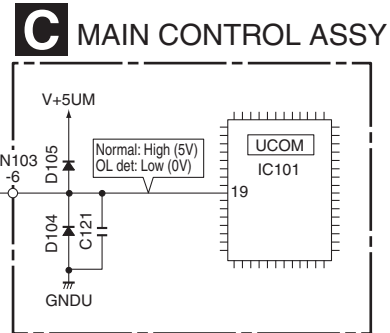
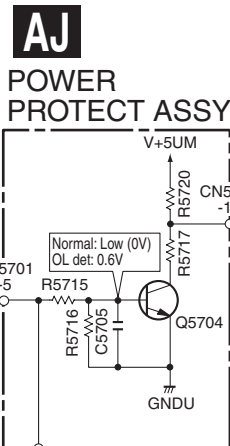
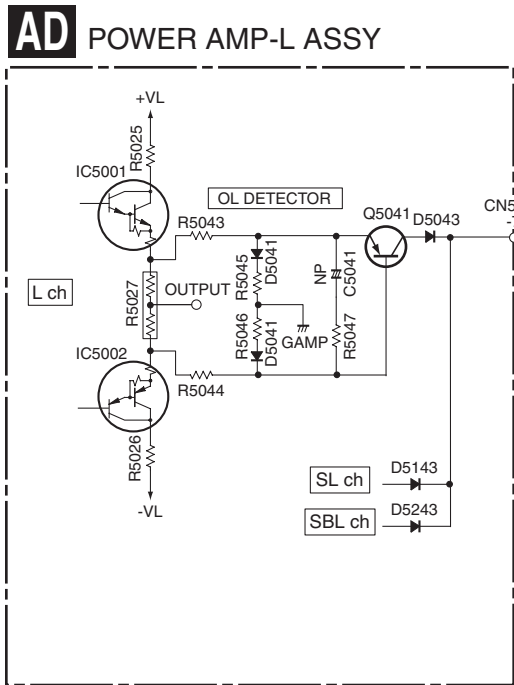

**AG** POWER AMP-R ASSY

**AI** POWER AMP IN ASSY

# 6. SERVICE MODE

## 6.1 TEST MODE

### Version indication

#### [Purpose]

The versions for various microcomputers and DSP firmware are displayed.

#### [How to enter/exit]

HY model:

During Standby mode, simultaneously press and hold the "STANDBY/ON" and "SOUND RETRIEVER" key for 5 seconds to enter this mode.

KU model:

During Standby mode, simultaneously press and hold the "STANDBY/ON" and "MULTI CH IN" keys for 5 seconds to enter this mode.

This mode is automatically exited when the indications of all versions have finished.

#### [Basic operations]

FL Display	Description of Version Indications	Duration (sec.)	Devices that can be considered generally normal, with the corresponding indications
POWER OFF ↓ M1.000 F1.000 ↓ D1.000 H1.000 ↓ f1.000 s1.000 ↓ Normal display	Mx.xxx : Main microcomputer Fx.xxx : Display microcomputer  Dx.xxx : DSP microcomputer Hx.xxx : HDMI microcomputer  fx.xxx : 1st DSP firmware sx.xxx : 2nd DSP firmware	5  5  5	Main microcomputer and display microcomputer  DSP microcomputer and HDMI microcomputer  1st DSP firmware : Flash ROM (IC106) near the DSP IC 2nd DSP firmware : Flash ROM within the DSP IC (IC201)

#### [Notes]

1. If the version indication becomes "\*\*\*," a failure in communications between the corresponding microcomputers or a failure in the corresponding microcomputers is likely.
2. In this submode, the user settings will not be cleared.

## ■ Detected protection history

### [Purpose]

The numbers of detections for various protection processes are displayed.

### [How to enter/exit]

HY model:

During Standby mode, simultaneously press and hold "DVR/VCR1" and "ENTER" keys for 5 seconds to enter this mode.

KU model:

During Standby mode, simultaneously press and hold "DVR1/DVR2" and "ENTER" keys for 5 seconds to enter this mode.

This mode is automatically exited when all the indications have finished.

### [Basic operations]

FL Display	Description of Indications	Duration (sec.)
POWER OFF ↓ DC : 000	Number of DC detections	3
↓ OVER: 010	Number of overload detections	3
↓ CON : 002	Number of detections of cord disconnection (DC and OL DET line) (simultaneous detections of DC and OVERLOAD)	3
↓ FAN : 002 (*)	Number of detections of fan abnormalities	3
↓ TEMP: 255	Number of detections of abnormal temperature	3
↓ Normal display		

(\*) for KU models, "FAN : 000" is always displayed.

### [Description]

When the keys are pressed, the numbers of DC detections, overload detections, detections of connectors disconnection inside unit (It is detected by both DC and OVERLOAD detections.), detections of fan abnormalities, and detections of abnormal temperature are displayed for 3 seconds each, in that order. The maximum value of each detections is 255.

## ■ Error indications when an abnormality in the amplifier system is detected

### [Purpose]

An error message is displayed when an abnormality in the amplifier system is detected.

### [Error Messages]

FL Display	Status	Duration (sec.)
AMP ERROR	When AMP DC is detected	Flashes 3 times.
FAN STOP (HY model Only)	When stopping of the fan is detected	Flashes 3 times.
OVERHEAT	When a thermal shutdown (abnormal temperature), etc. is detected	Flashes 3 times.
12V TRG ERR KUXJ and KUXJ/CA models only	When the 12-V trigger circuit is short-circuited	Flashes
XM Power Error KUXJ and KUXJ/CA models only	The power supply of the XM antenna is abnormally	Flashes

### [Description]

**AMP ERROR** : After a failure in the amplifier block or high DC output is detected, the shutdown process starts, then the power will be shut off. Then the MCACC LED will flash. The power cannot be turned on again. If you wish to turn on the unit after a shutdown activated by DC detection, enter Test mode, by proceeding with the steps described in "How to enter release mode" below.

**FAN STOP** : The fan does not function.  
(HY model Only)

**OVERHEAT** : The temperature of the amplifier is abnormally high.

**12V TRG ERR** : The 12-V trigger output is short-circuited.  
(KUXJ and KUXJ/CA models only)

**XM Power Error** : The power supply of the XM antenna is abnormally.  
(KUXJ and KUXJ/CA models only)

After a failure is detected, the shutdown process starts, then the power will be off. The power can be turned on again in Normal mode.

### [How to enter release mode]

Press and hold **HY model : DVR/VCR2, KU model : VIDEO/GAME** and **ENTER** keys on the front panel simultaneously for 5 seconds in standby mode.

# 7. DISASSEMBLY

**Note 1:** Even if the unit shown in the photos and illustrations in this manual may differ from your product, the procedures described here are common.

**Note 2:** For performing the diagnosis shown below, the following jigs for service is required:

- 11P board to board extension jig cable (GGD1482)
- 13P board to board extension jig cable (GGD1483)
- 15P board to board extension jig cable (GGD1484)
- 21P board to board extension jig cable (GGD1485)

## 1. Before the Power Amp Block is removed

Before the Power Amp Block is removed, discharge C3257 and C3258 on the TRANS 2-1 Assy, as indicated below. If you don't, the IC protectors (IC3351 and IC3352) on the VH TR Assy may be open, and DC voltage may be generated at the power amplifier output, which will result in "AMP ERR."

### [Procedure]

- ① Unplug the AC power cord.
- ② Discharge C3257 and C3258 on the TRANS 2-1 Assy.  
**Note:** For discharging, use a load of 100Ω, 3W or more, to protect the IC protectors. Do NOT discharge instantly by short-circuiting.
- ③ Check that the voltage between the electrodes of each C3257 and C3258 is 1V or less.
- ④ Reassembling the Power Amp Block.

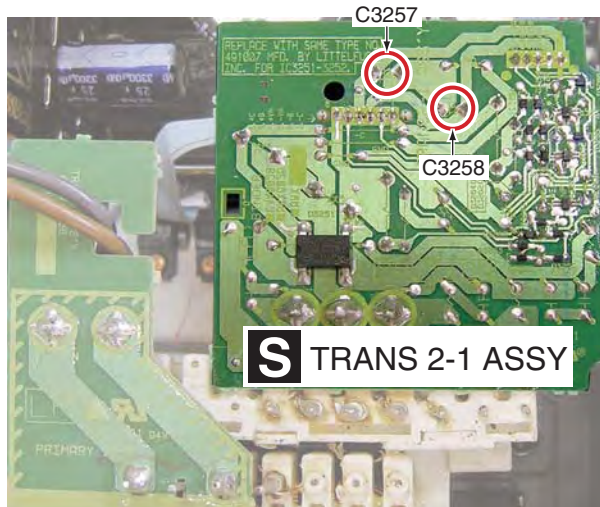
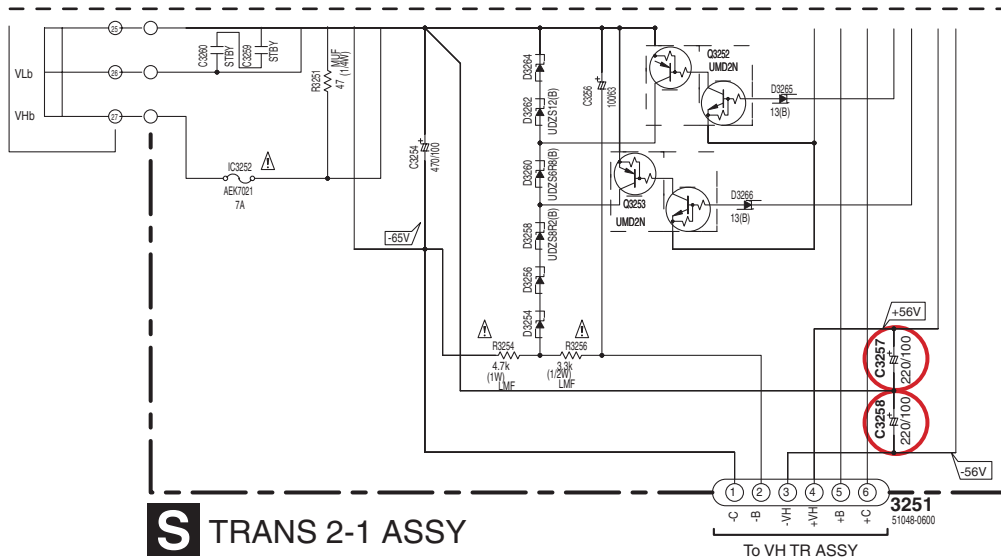

## 2. Disassembly

### 1 Bonnet

① Remove the eight screws.

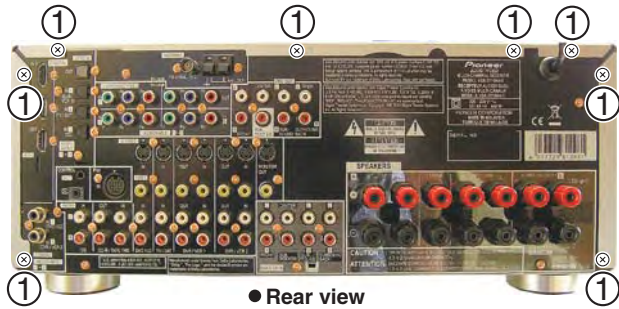

② Remove the eight screws.

③ Remove the bonnet.

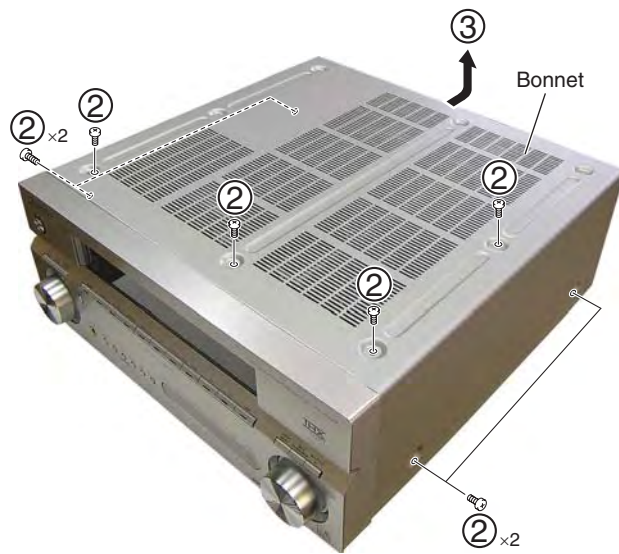

### 2 Power Amp Block

#### Caution:

Before removing the Power Amp Block, discharge C3257 and C3258 on the TRANS 2-1 Assy. Refer to "1. Before the Power Amp Block is removed".

① Remove the seven screws.

② Disconnect the three flexible cables and the one connector.

③ Disconnect the one jumper wire.

④ Disconnect the six connectors.

⑤ Remove the power amp block.

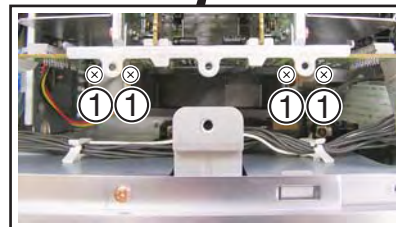
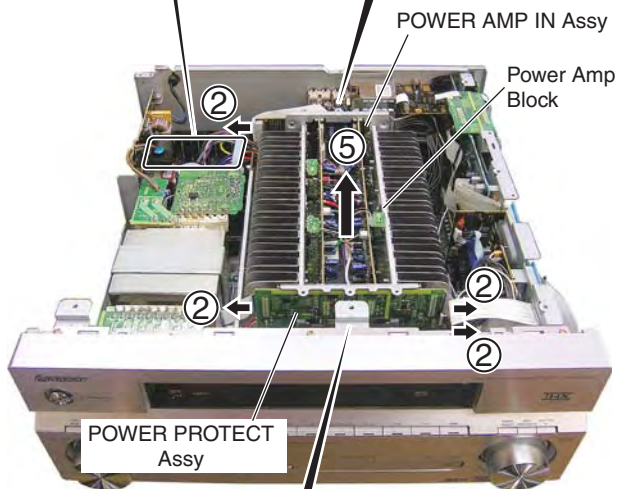
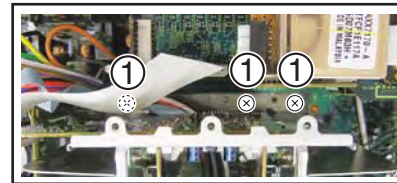
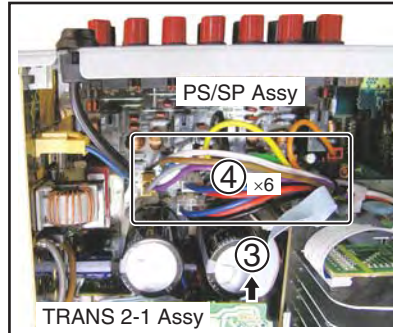

### 3 Replacing the Power Transistor

#### ● POWER PROTECT Assy

- ① Remove the one nylon rivet.
- ② Disconnect the one connector. (VSX-LX50 only)
- ③ Remove the POWER PROTECT Assy by removing the two connectors.

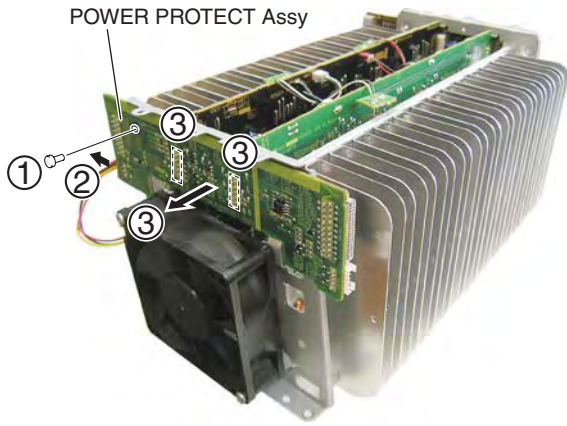

#### ● HS Angle 2016

- ① Remove the four screws.
- ② Remove the HS angle 2016.

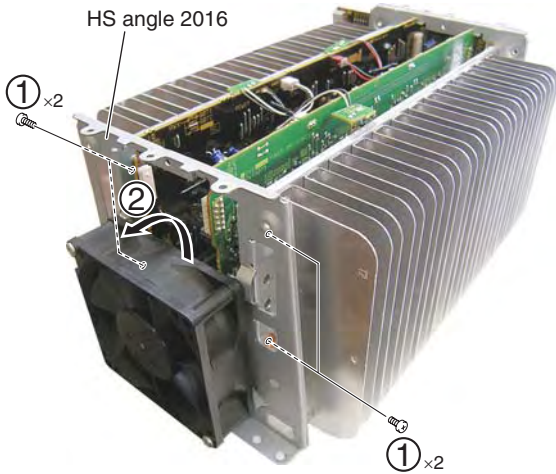

#### ● POWER AMP IN Assy

- ① Remove the one nylon rivet.
- ② Remove the POWER AMP IN Assy by removing the four connectors.

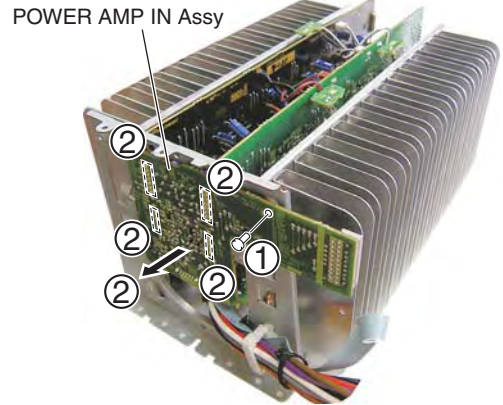

#### ● HS Angle 2016

- ① Remove the four screws.
- ② Release the clumper.
- ③ Remove the HS angle 2016.

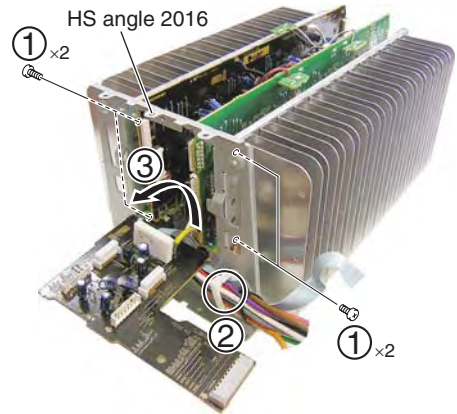

#### ● Replacing the Power Transistor

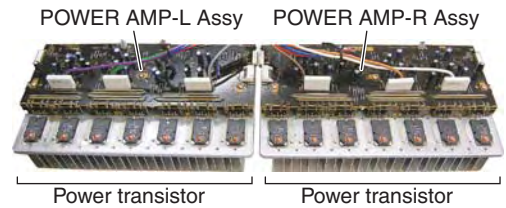

**Replace**



### 4 Replacing the AUDIO IN Assy

#### ● Rear Panel

- ① Disconnect the one connector.
- ② Remove the four cushion circle 14B.
- ③ Remove the four screws.
- ④ Remove the one screw.  
(KU model: Remove the three screws.)
- ⑤ Remove the three screws.

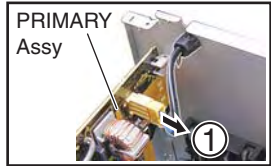

#### ● Rear view

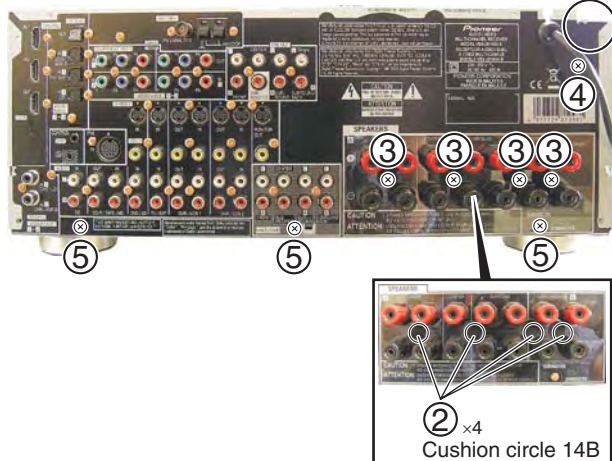

- ⑥ Remove the one screw.
- ⑦ Remove the three screws.  
(KU model: Remove the 4 screws.)
- ⑧ Remove the 32 screws.  
(KU model: Remove the 33 screws.)
- ⑨ Remove the rear panel.

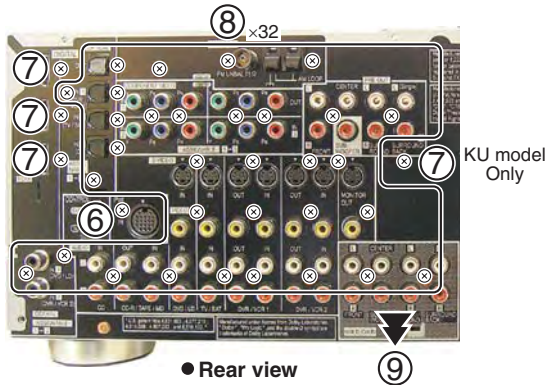

#### ● FM/AM TUNER Unit

- ① Remove the FM/AM TUNER Unit by removing the one flexible cable.

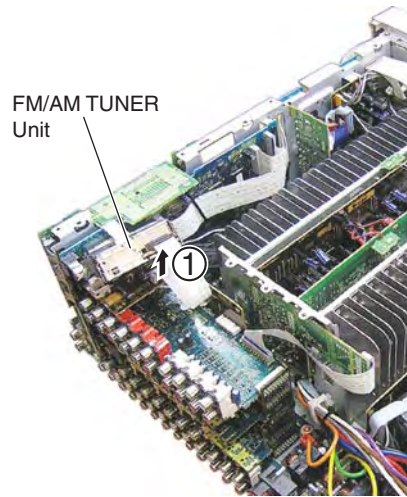

#### ● PCB Assys

- ① Disconnect cables, connectors, as required.
- ② First remove the BRIDGE 2 Assy, then remove the COMPOSITE, S-VIDEO, COMPONENT and VIDEO CONNECT Assys.

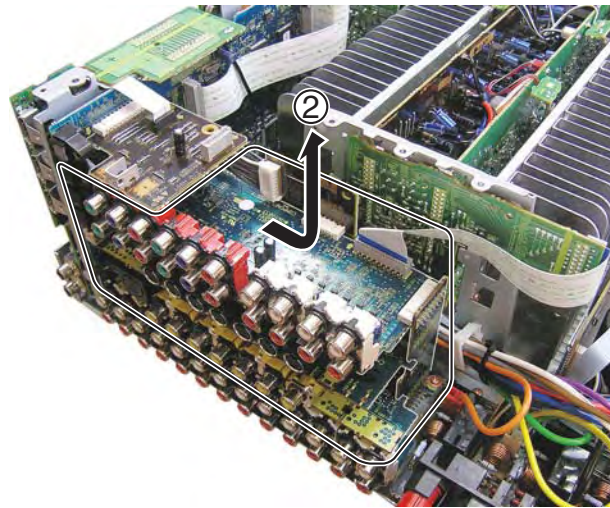

### ● DSP Shield Section

- ① Remove the one screw.
- ② Remove the two screws.
- ③ Disconnect cables, connectors, as required.
- ④ Remove the DSP shield 2016 with PCB Assemblies..

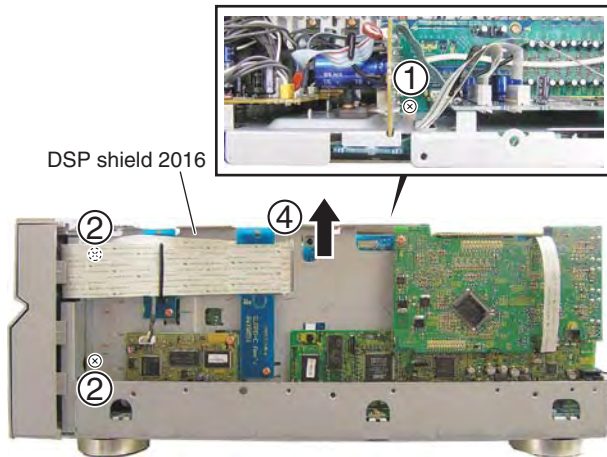

### ● AUDIO IN Assy

- ① Remove the two screws.
- ② Remove the five screws.
- ③ Release the locking card spacer.
- ④ Disconnect cables, connectors, as required.
- ⑤ Remove the AUDIO IN Assy.

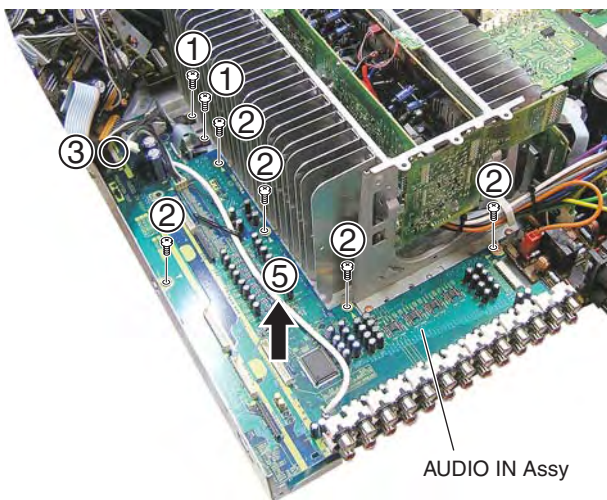

## 3. Diagnosis

### 1 Preparations

- ① Remove the bonnet.
  - ② Remove the rear panel.
- 
- ① Remove the BRIDGE 2 Assy.
  - ② Remove the VIDEO CONNECT Assy.
  - ③ Remove the COMPONENT, S-VIDEO, COMPOSITE Assys.

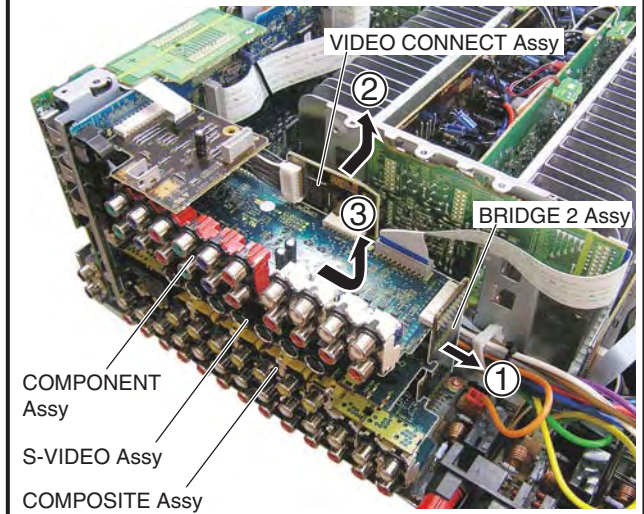

- ④ Connect the earth points to chassis as follows.
  - a Pin jack (GND) on the DSP Assy ↔ chassis
  - b Pin jack (L side GND) on the AUDIO IN Assy ↔ chassis
  - c Pin jack (Yellow GND) on the COMPOSITE Assy ↔ chassis
  - d Speaker terminal (L side black) ↔ chassis

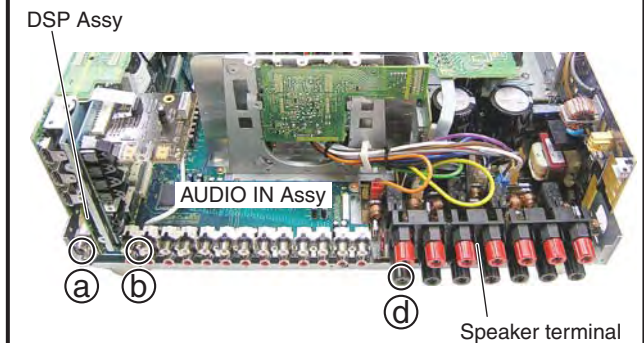

## 2 Diagnosis

### ● COMPONENT Assy

#### Jig cable

- 11P board to board extension jig cable (GGD1482)
- 13P board to board extension jig cable (GGD1483) ×2

- ① Connect the three extension jig cables.
- ② Reassembling the S-VIDEO and COMPOSITE Assys.
- ③ Reassembling the VIDEO CONNECT Assy.
- ④ Connect the one flexible cable.
- ⑤ Insert the insulation sheet.
- ⑥ Arrange the unit as shown in the photo below.

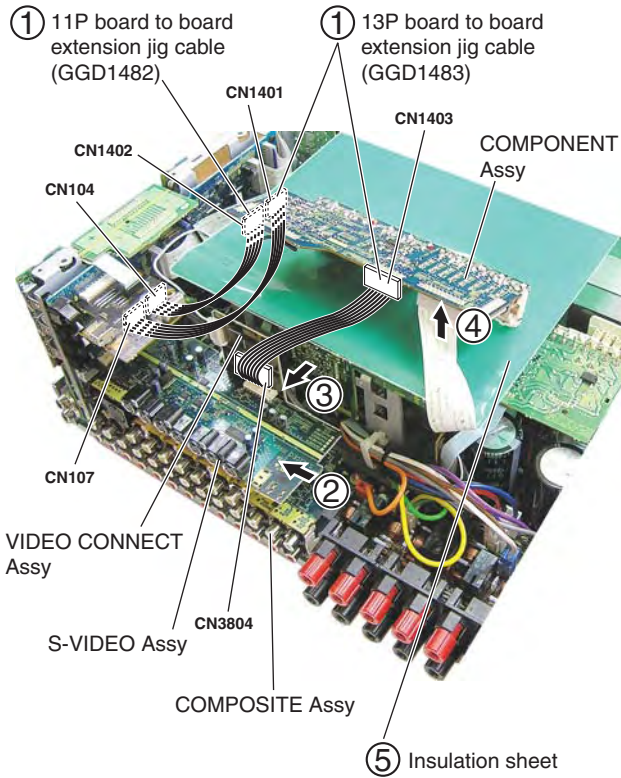

Diagnosis

### ● S-VIDEO Assy

#### Jig cable

- 13P board to board extension jig cable (GGD1483)
- 15P board to board extension jig cable (GGD1484) ×2

- ① Connect the three extension jig cables.
- ② Reassembling the COMPONENT and COMPOSITE Assys.
- ③ Reassembling the BRIDGE 2 and VIDEO CONNECT Assys.
- ④ Connect the one flexible cable.

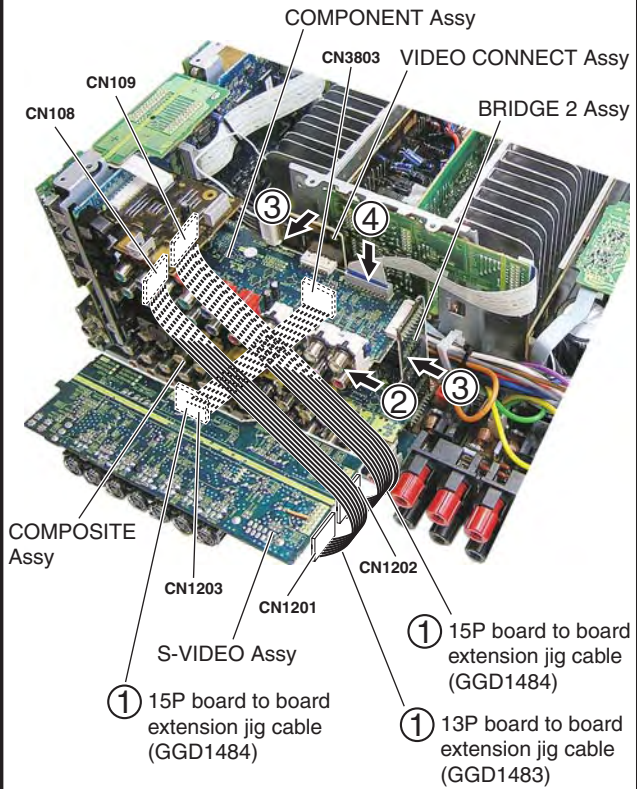

Diagnosis

## ● COMPOSITE Assy

### Jig cable

- 11P board to board extension jig cable (GGD1482)
- 13P board to board extension jig cable (GGD1483)
- 21P board to board extension jig cable (GGD1485)

- ① Connect the three extension jig cables.
- ② Reassembling the COMPONENT and S-VIDEO Assys.
- ③ Reassembling the BRIDGE 2 and VIDEO CONNECT Assys.
- ④ Connect the one flexible cable.

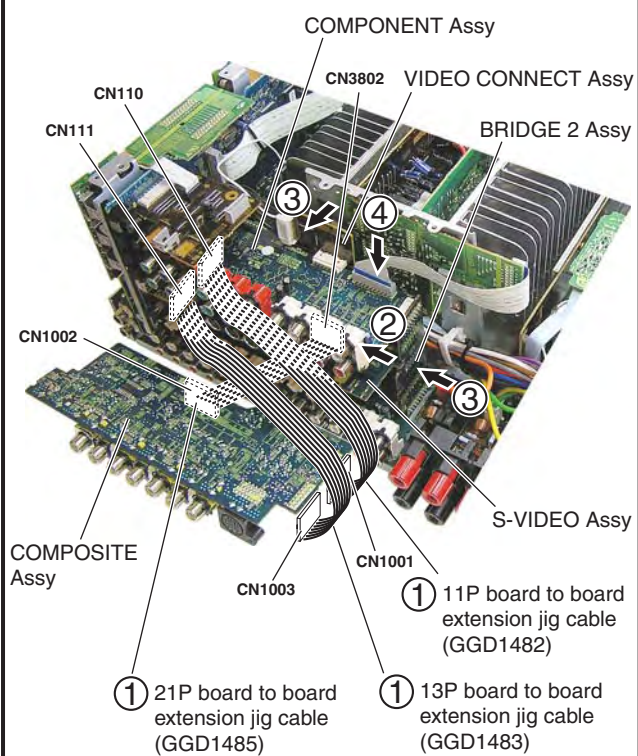

# 8. EACH SETTING AND ADJUSTMENT

## 8.1 ADJUSTMENT

- There is no information to be shown in this chapter.

## 8.2 HOW TO UPDATE FIRMWARE

### HDMI, MAIN and DSP microcomputer

#### [Purpose]

Refer to this section when updating the firmware of each microcomputer is required by the service information, etc.

#### [Necessary Tools]

- PC with RS232C port
- RS-232C straight cable (9pin female ↔ 25pin male)
- RS-232C cross cable (9pin female ↔ 9pin female)
- RS-232C Interface jig : GGF1348
- 7 pin FFC : VDA1681
- Updating program : UFU.exe
- Firmware file : ".mot" file

#### [Connections for updating HDMI ucom]

##### - All models -

Connect as shown in the figure below.

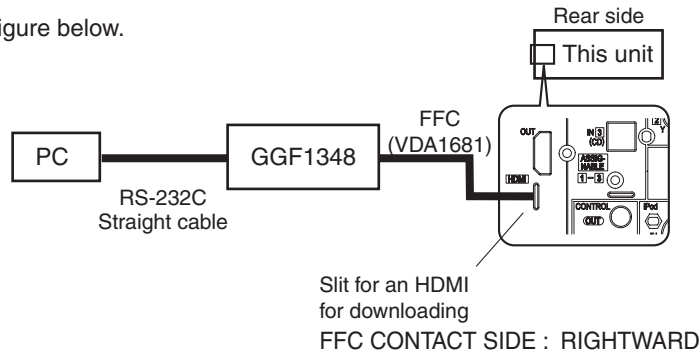

#### [Connections for updating MAIN and DSP ucom]

##### - HY model -

Connect as shown in the figure below.

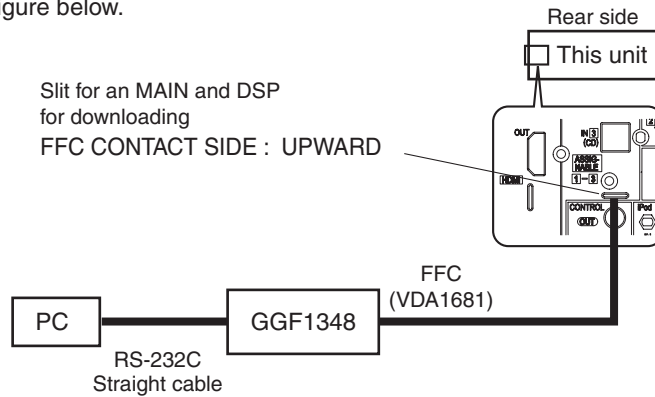

##### - KU models -

Connect as shown in the figure below.

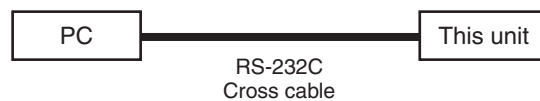

**[Note]**

Do NOT disconnect the AC power cords of this unit and the PC during a downloading.

**[Procedures]**

- Set the main volume level to "---dB" then turn off the unit (Standby mode).
- Connect the PC and the unit as shown in "Connections".
- HDMI ucom:**
  - HY model  
Simultaneously press and hold the ENTER and FM/AM keys for about 5seconds.
  - KU models  
Simultaneously press and hold the ENTER and XM keys for about 5seconds.

The unit is turned on and "HDMI DOWNLOAD" is displayed.

**MAIN ucom:**

Simultaneously press and hold the ENTER and HDMI keys for about 5seconds.

The unit is turned on and "MAIN DOWNLOAD" is displayed.

**DSP ucom:**

- HY model  
Simultaneously press and hold the ENTER and USB keys for about 5seconds.
- KU models  
Simultaneously press and hold the ENTER and SIRIUS keys for about 5seconds.

The unit is turned on and "DSPM DOWNLOAD" is displayed.

- Double-click the "UFU.exe".
- Check that "Full" is selected in Mode Select.

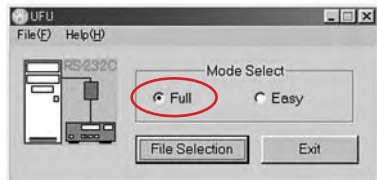

- Select the firmware file (.mot file) for updating each ucom.  
**Note:** Do NOT download the firmware file for other ucom.
- Select the communication speed.
  - Basic speed: 19200
  - Data transfer speed: 57600

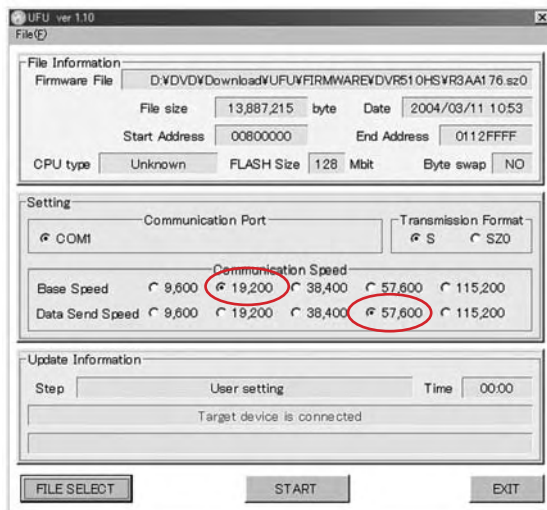

- Click the "START" button.
- HDMI ucom:** "Completed" is displayed on the "UFU.exe" window about 1 minute later.
- MAIN, DSP ucom:** "Completed" is displayed on the "UFU.exe" window about 3 minutes later.
- Disconnect then reconnect the AC power cord of the unit. If the unit is not reset, retry from step2.
- Reset the AV receiver.

**Note:** Note that all the data the receiver retains will be cleared.

**Resetting the receiver**

Use this procedure to reset all the receiver's settings to the factory default. Use the front panel controls to do this.

**1 Switch the receiver into standby.****2 While holding down the front panel TONE button, press and hold STANDBY/ON for about three seconds.**

The display shows **RESET?**.

**3 Press the front panel ENTER button.**

The display shows **RESET OK?**.

**4 Press SETUP to confirm.**

OK appears in the display to indicate that the receiver has been reset to the factory default settings.

- Check the version.  
Please refer to "Version indication" (p72) and check that the version has been changed to a new one.

## DSP FLASH ROM

### [Purpose]

Refer to this section when updating the DSP flash ROM firmware is required by the service information, etc.  
It is able to update the DSP flash ROM firmware by playing back a CD-R which is recorded a DSP firmware (.wav file) via digital connection.

### [Necessary Tools]

- DVD player
- Coaxial cable or Optical cable
- Update disc (CD-R disc)

#### Note:

Please use DVD player based on MTK system (DV-270, 370, 373, 575K, 280, 380, 383, etc.), Mitsubishi system (DV-59AVi, 868AVi, S969AVi, 668AVi, etc.) and Fujitsu system (DV-343, 444, 545, etc.).

DO NOT use DVD player based on ST system (DV-353, 454, 250, 400, 555K, 260, 363, 464, 466, 563, etc.).

The factory confirmed that DVD players based on ST system cannot send the correct data to the receiver.

You can check the base system of our DVD players on the firmware version list at PSN web (Niis).

### [Connections]

Connect as shown in the figure below.

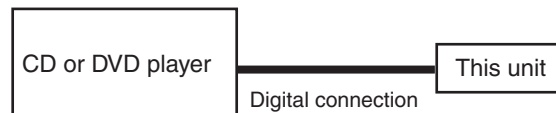

### [Preparations]

Burn the DSP flash ROM firmware (.wav file) to a CD-R disc using commercially available burning software.

It is necessary to select the writing format to "For music player", not "For PC data".

#### Note:

Depending on a burning software, data on a CD-R may not be worked for updating the DSP flash ROM.

If the HDMI indicator does not flash when playing back a update disc, the disc is not able to use for updating.

Burn the DSP flash ROM firmware to a CD-R disc, using other burning software.

### [Note]

- Do NOT disconnect the AC power cords of this unit and the CD/DVD player during a updating.
- "OK" is appeared on the FL display when updating is completed.

If the "OK" is not appeared, updating has not been completed correctly. Be sure to perform the updating procedures again.

### [Procedures]

1. Reset the receiver.

**Note:** Note that all the data the receiver retains will be cleared.

#### Resetting the receiver

Use this procedure to reset all the receiver's settings to the factory default. Use the front panel controls to do this.

#### 1 Switch the receiver into standby.

**2 While holding down the front panel TONE button, press and hold STANDBY/ON for about three seconds.**

The display shows **RESET?**.

#### 3 Press the front panel ENTER button.

The display shows **RESET OK?**.

#### 4 Press SYSTEM SETUP to confirm.

OK appears in the display to indicate that the receiver has been reset to the factory default settings.

2. Check the version of the DSP flash ROM (1st DSP) and the DSP ucom.

Please refer to "Version indication" (p72).

3. Connect a CD or DVD player

(1) Connect the CD or DVD player for updating to any digital input jack of this unit.

(2) Select the input source to the connected source by pressing input source key.

**[Procedures]**

4. Confirm that the digital input signal is locked on the AV receiver.
  - (1) Play back the update disc on the CD/DVD player.
  - (2) Set the signal select setting of the AV receiver to the "Auto" then confirm that the Signal Select indicator is Digital.
  
5. Enter the DSP flash ROM updating mode.
  - (1) Skip to the beginning (time:0:00) of the first track of the update disc and set to Pause.
  - (2) Set the main volume level of the AV receiver to "---dB" then turn off the unit (Standby mode).
  - (3) Simultaneously press and hold the ENTER and iPod keys for about 5seconds.  
The unit is turned on and "DSPF DOWNLOAD" is displayed.
  
6. Play back the first track of the update disc.
  - (1) Release Pause mode of the CD/DVD player and start to play back the DSP update program stream.
  - (2) After 5-10 seconds, the HDMI indicator starts flashing. Be sure to check it.  
Flashing of the HDMI indicator means that the unit is receiving a correct stream and the updating is in progress.

**Note:**  
Do NOT turn off the unit while the HDMI indicator is flashing. If the unit is turned off, be sure to go back to Step 5. (As the Flash ROM goes into unusual status if the power is off during updating, the unit may not start properly.) Even in such a case, you can restore the unit by performing Steps 5 to 8.
  
7. Wait until "OK" is appeared on the FL display.
  - (1) It takes about 2 minutes for updating.
  - (2) After confirming the "OK", stop or pause the CD/DVD player and wait for 5 seconds then turn off the power of the AV receiver (Standby mode).
  
8. Check the version of the DSP flash ROM (1st DSP).  
Please refer to "Version indication" (p72) and check that the version has been changed to a new one.

## ■ USB (HY model only)

### [Purpose]

Refer to this section when updating the USB firmware is required by the service information, etc.  
It is able to update the USB firmware by using USB flash memory.

### [Necessary Tools]

- USB Flash Memory which is saved the firmware file ("player.rom" file).

#### **Note:**

In rare cases, it is not able to update the firmware depending on the type of USB flash memory.  
In such a case, try to use other model of USB flash memory.

### [Procedures]

1. Turn on the unit then press and hold "SOUND RETRIEVER" and "ENTER" key for about 5sec.
2. "USB" is appeared on the FL display.
3. "TESTMODE" is appeared on the FL display.
4. "CORE\*.\*\*" is appeared on the FL display. (\*.\*\* : F/W version No.)
5. Connect the USB flash memory which is saved the firmware file ("player.rom" file).
6. "UPDT" is displayed on the FL display.
7. Wait until "FINISHED" is appeared on the FL display.
8. Disconnect the USB flash memory then set the function setting to anything other than USB.
9. Turn off the unit (Standby mode).

#### **Note:**

- Do NOT reconnect the USB flash memory which is saved the "player.rom" file.
- Do NOT change the function setting or turn off the power during step 5 through 7.  
If you do, the updating is failed and it is required to replace the USB flash ROM on the USB module.

■

5

■

6

■

7

■

8

■

A

■

B

■

C

■

D

■

E

■

F

■

5

■

6

VSX-LX50

■



7

■

8

■

# 9. EXPLODED VIEWS AND PARTS LIST

- NOTES:**
- Parts marked by "NSP" are generally unavailable because they are not in our Master Spare Parts List.
  - The  mark found on some component parts indicates the importance of the safety factor of the part. Therefore, when replacing, be sure to use parts of identical designation.
  - Screws adjacent to  mark on product are used for disassembly.
  - For the applying amount of lubricants or glue, follow the instructions in this manual. (In the case of no amount instructions, apply as you think it appropriate.)

## 9.1 PACKING

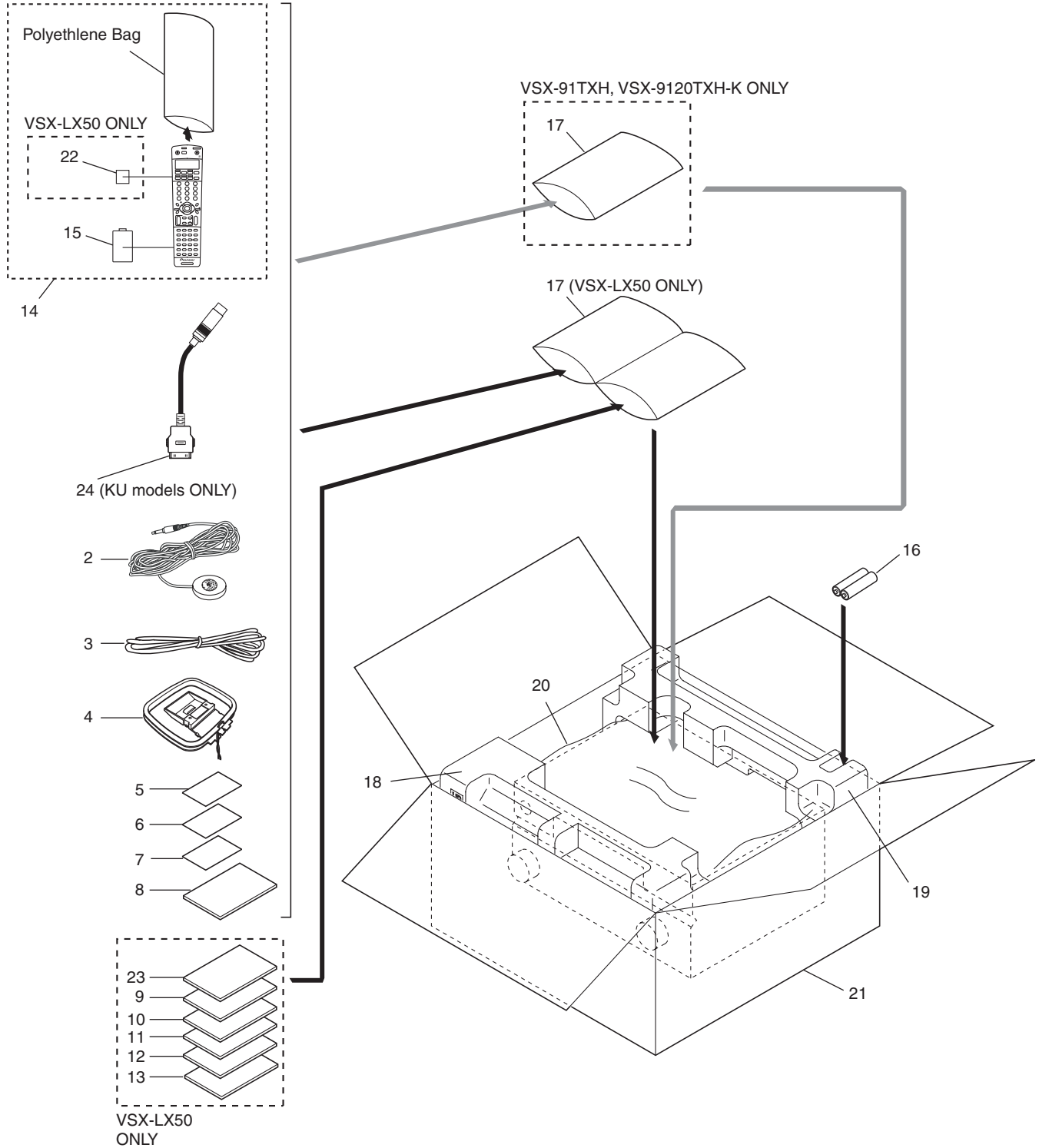

**(1) PACKING SECTION PARTS LIST**

<u>Mark No.</u>	<u>Description</u>	<u>Part No.</u>	<u>Mark No.</u>	<u>Description</u>	<u>Part No.</u>
1	•••••		15	Battery Cover	XZN3140
2	Setup Microphone (for Auto MCACC setup)	APM7008	NSP 16	Dry Cell Battery AA/LR6	VEM1031
3	FM Wire Antenna	ADH7030	NSP 17	Polyethylene Bag	See Contrast table (2)
4	AM Loop Antenna	ATB7013	18	Front Pad	AHA7456
			19	Rear Pad	AHA7457
NSP 5	Warranty Card	See Contrast table (2)	20	Packing Sheet	RHC1023
6	Caution Sheet(Spanish/English)	ARM7083	21	Packing Case	See Contrast table (2)
7	Disclaimer	See Contrast table (2)	22	LABEL (WEEE)	See Contrast table (2)
8	Operating Instructions (English)	See Contrast table (2)	23	Operating Instructions (Russian)	See Contrast table (2)
9	Operating Instructions (French)	See Contrast table (2)	24	Audio Control Cable for iPod	See Contrast table (2)
10	Operating Instructions (German)	See Contrast table (2)			
11	Operating Instructions (Italian)	See Contrast table (2)			
12	Operating Instructions (Spanish)	See Contrast table (2)			
13	Operating Instructions (Dutch)	See Contrast table (2)			
14	Remote Control Unit	See Contrast table (2)			

**(2) CONTRAST TABLE**

VSX-LX50/HYXJ5, VSX-91TXH/KUXJ/CA and VSX-9120TXH-K/KUXJ are constructed the same except for the following:

<u>Mark</u>	<u>No.</u>	<u>Symbol and Description</u>	<u>VSX-LX50/ HYXJ5</u>	<u>VSX-91TXH/ KUXJ/CA</u>	<u>VSX-9120TXH-K/ KUXJ</u>	
NSP	5	Warranty Card	ARY7065	ARY7007	ARY7045	
	7	Disclaimer (English/French/German/Italian/ Spanish/Dutch)	XRM3010	Not used	Not used	
	7	Disclaimer (English/French)	Not used	XRM3008	XRM3008	
	8	Operating Instructions (English)	ARB7371	ARB7369	ARB7370	
	9	Operating Instructions (French)	ARC7728	Not used	Not used	
	10	Operating Instructions (German)	ARC7729	Not used	Not used	
	11	Operating Instructions (Italian)	ARC7730	Not used	Not used	
	12	Operating Instructions (Spanish)	ARC7731	Not used	Not used	
	13	Operating Instructions (Dutch)	ARC7732	Not used	Not used	
	14	Remote Control Unit	AXD7491	AXD7490	AXD7497	
	NSP	17	Polyethylene Bag	AHG7132	AHG7117	AHG7117
		21	Packing Case LX50HY	AHD8525	Not used	Not used
		21	Packing Case 91KU	Not used	AHD8523	Not used
		21	Packing Case 9120KKU	Not used	Not used	AHD8524
22		LABEL (WEEE)	ARW7322	Not used	Not used	
23		Operating Instructions (Russian)	ARC7767	Not used	Not used	
24		Audio Control Cable for iPod	Not used	XDE7025	XDE7025	

# 9.2 EXTERIOR SECTION

A  
B  
C  
D  
E  
F

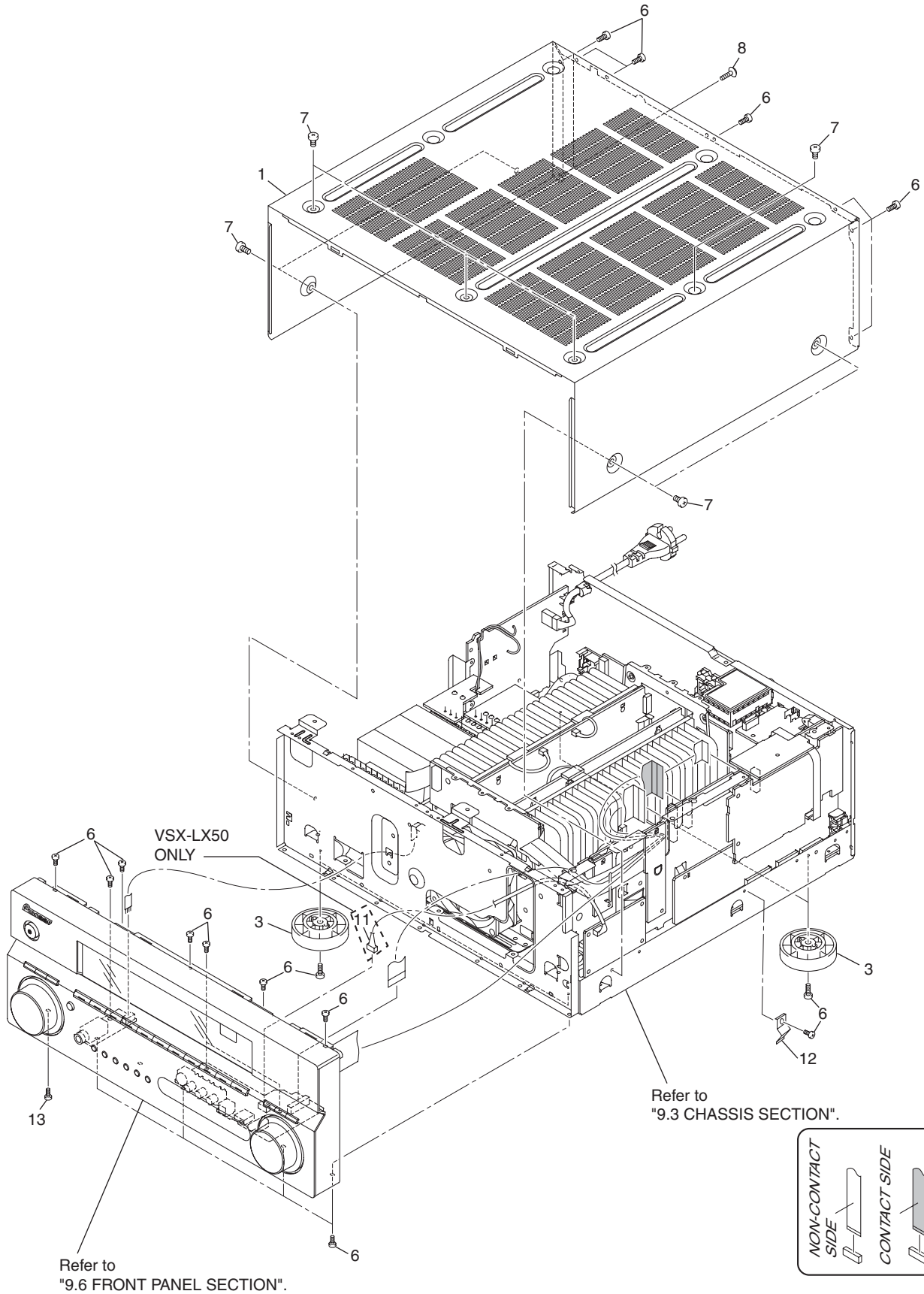

**(1) EXTERIOR SECTION PARTS LIST**

<u>Mark No.</u>	<u>Description</u>	<u>Part No.</u>	<u>Mark No.</u>	<u>Description</u>	<u>Part No.</u>
1	Bonnet 81B	AZN8021	11	4P Shielded Cable	See Contrast table (2)
2	.....		12	Earth Spring	ABH7245
3	Insulator	See Contrast table (2)	13	Screw	BBT30P080FNI
4	.....				
5	.....				
6	Screw	BBZ30P080FCC			
7	Screw	BCZ40P060FTB			
8	Screw	IBP30P090FCC			
9	.....				
10	.....				

**(2) CONTRAST TABLE**

VSX-LX50/HYXJ5, VSX-91TXH/KUXJ/CA and VSX-9120TXH-K/KUXJ are constructed the same except for the following:

Mark	No.	Symbol and Description	VSX-LX50/ HYXJ5	VSX-91TXH/ KUXJ/CA	VSX-9120TXH-K/ KUXJ
	3	Insulator	DXA1904	AMR7198	PNW2766
	11	4P Shielded Cable	XDX3028	Not used	Not used

# 9.3 CHASSIS SECTION

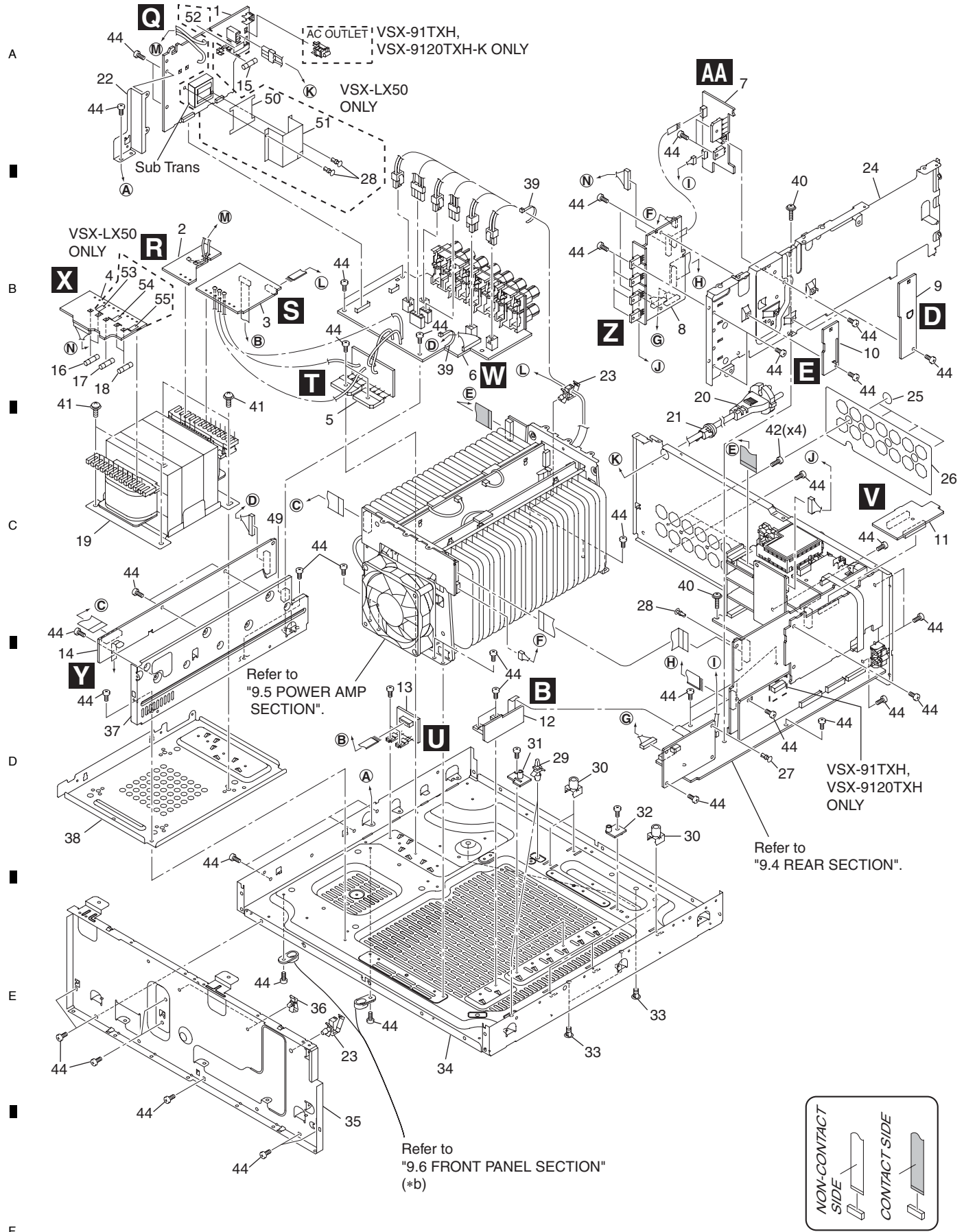

**(1) CHASSIS SECTION PARTS LIST**

<u>Mark No.</u>	<u>Description</u>	<u>Part No.</u>	<u>Mark No.</u>	<u>Description</u>	<u>Part No.</u>
1	PRIMARY Assy	See Contrast table (2)	26	SP Sheet 2016	AEC7560
2	TRANS 1 Assy	AWX9038	27	Nyron Rivet	AEC7408
3	TRANS 2-1 Assy	See Contrast table (2)	28	Nyron Rivet	AEC7406
4	TRANS 2-2 Assy	AWX9062	29	Locking Card Spacer	PNW2917
5	DIODE 1 Assy	AWX9060	30	PCB Mold	AMR2534
6	PS/SP Assy	See Contrast table (2)	31	Inter Holder A	AMR7500
7	DC/DC Assy	AWX9015	32	Inter Holder B	AMR7501
8	LOCAL P-SUPPLY Assy	See Contrast table (2)	33	Card Spacer	DNK2769
9	GUARD-C Assy	AWX8826	NSP 34	Under Base 2016	ANA7189
10	GUARD-F Assy	AWX8825	NSP 35	Panel Stay 2016	AND7082
11	BRIDGE 1 Assy	AWX9078	36	Side Clamp	DEC2007
12	12V-REG Assy	AWX8824	37	Under Beam V1	ANG7478
13	VH TR Assy	AWX9061	NSP 38	Trans Frame 74	ANG7539
14	TRANS SIDE Assy	AWX9056	NSP 39	Binder	ZCA-BK1
⚠ 15	Fuse (FU1)	See Contrast table (2)	40	Screw 3x15	ABA7100
⚠ 16	Fuse (FU7,FU8)	See Contrast table (2)	41	Screw	ABA7109
⚠ 17	Fuse (FU4)	See Contrast table (2)	42	Screw	BBT30P100FCC
⚠ 18	Fuse (FU5,FU6)	See Contrast table (2)	44	Screw	BBZ30P080FCC
⚠ 19	Power Transformer (T1501)	See Contrast table (2)	49	Bridge Spacer	AEB7201
⚠ 20	AC Power Cord	See Contrast table (2)	50	Primary Barrier	See Contrast table (2)
21	Cord Stopper	See Contrast table (2)	51	Shield Case	See Contrast table (2)
22	Primary Angle 56	ANG7526	NSP 52	Fuse Card	See Contrast table (2)
NSP 23	Wire Saddle	DEC1450	NSP 53	Fuse Card	See Contrast table (2)
24	DSP Shield 2016	ANG7546	NSP 54	Fuse Card	See Contrast table (2)
25	Cushion Circle 14B	AED7081	NSP 55	Fuse Card	See Contrast table (2)

**(2) CONTRAST TABLE**

VSX-LX50/HYXJ5, VSX-91TXH/KUXJ/CA and VSX-9120TXH-K/KUXJ are constructed the same except for the following:

<u>Mark</u>	<u>No.</u>	<u>Symbol and Description</u>	<u>VSX-LX50/ HYXJ5</u>	<u>VSX-91TXH/ KUXJ/CA</u>	<u>VSX-9120TXH-K/ KUXJ</u>
	1	PRIMARY Assy	AWX9035	AWX9034	AWX9034
	3	TRANS 2-1 Assy	AWX9059	AWX9058	AWX9058
	6	PS/SP Assy	AWX9107	AWX9052	AWX9052
	8	LOCAL P-SUPPLY Assy	AWX9064	AWX9063	AWX9063
⚠	15	Fuse (FU1: T5 A L 250 V)	REK1029	Not used	Not used
⚠	15	Fuse (FU1: 10 A/125 V)	Not used	REK1154	REK1154
⚠	16	Fuse (FU7,FU8: T2.5 A L 250 V)	REK1026	Not used	Not used
⚠	16	Fuse (FU7,FU8: 2.5 A/125 V)	Not used	REK1146	REK1146
⚠	17	Fuse (FU4: T4 A L 250 V)	REK1028	Not used	Not used
⚠	17	Fuse (FU4: 5 A/125 V)	Not used	REK1067	REK1067
⚠	18	Fuse (FU5,FU6: T800 mA L 250 V)	REK1021	Not used	Not used
⚠	18	Fuse (FU5,FU6: 1.25 A/125 V)	Not used	REK1143	REK1143
⚠	19	Power Transformer (T1501)	ATS7408	ATS7407	ATS7407
⚠	20	AC Power Cord	VDG1080	VDG1075	VDG1075
	21	Cord Stopper	CM-22B	CM-22C	CM-22C
	50	Primary Barrier	AEC7569	Not used	Not used
	51	Shield Case	AMR7526	Not used	Not used
NSP	52	Fuse Card	AAX7098	Not used	Not used
NSP	53	Fuse Card	AAX7277	Not used	Not used
NSP	54	Fuse Card	AAX7099	Not used	Not used
NSP	55	Fuse Card	AAX2367	Not used	Not used

# 9.4 REAR SECTION

## ● VSX-LX50

A

B

C

D

E

F

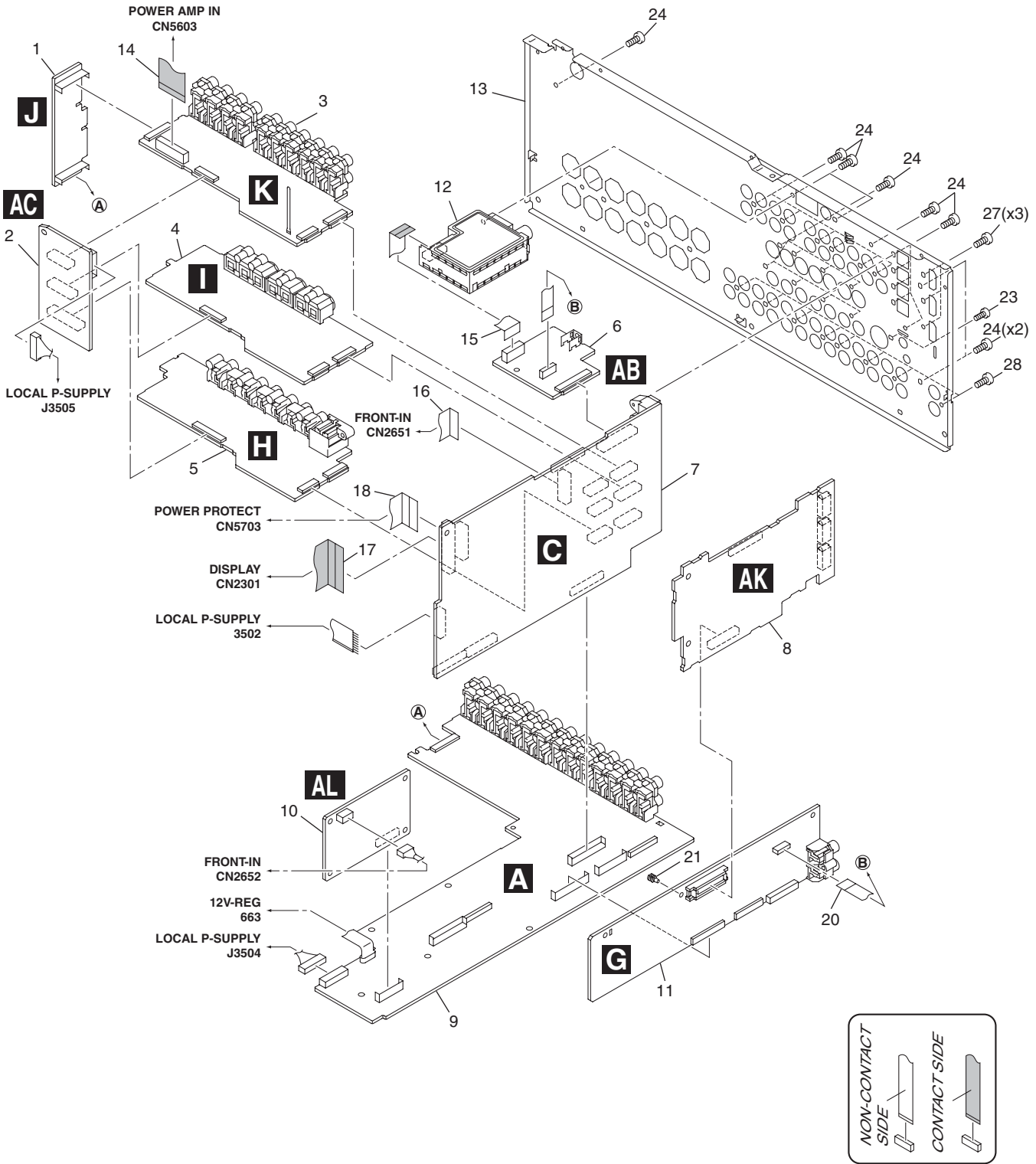

**(1) REAR SECTION PARTS LIST**

<u>Mark No.</u>	<u>Description</u>	<u>Part No.</u>	
1	BRIDGE 2 Assy	AWX8850	
2	VIDEO CONNECT Assy	AWX9069	A
3	COMPONENT Assy	AWX8848	
4	S-VIDEO Assy	AWX8845	
5	COMPOSITE Assy	AWX8842	
6	IR I/O Assy	AWX9067	
7	MAIN CONTROL Assy	AWX8817	
8	HDMI & DVC Assy	AWQ7040	
9	AUDIO IN Assy	AWX8821	
10	USB Assy	AWX8866	
11	DSP Assy	AWX8814	B
12	FM/AM Tuner Unit	AXX7248	
13	Rear Panel LX50HY	ANC8469	
14	19P FFC/60V (J58)	ADD7535	
15	11P FFC/60V (J59)	ADD7536	
16	17P FFC/60V (J54)	ADD7540	
17	29P FFC/60V (J55)	ADD7532	
18	19P FFC/60V (J56)	ADD7533	
20	10P FFC/60V (J51)	ADD7528	
21	Card Spacer	AEC7214	
23	Screw	BBZ26P080FCC	C
24	Screw	BBZ30P080FCC	
27	Screw	PMZ30P060FCC	
28	Screw	BBT30P080FNI	

● VSX-91TXH, VSX-9120TXH-K

A

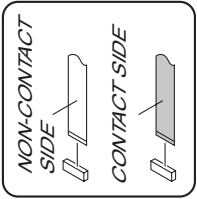
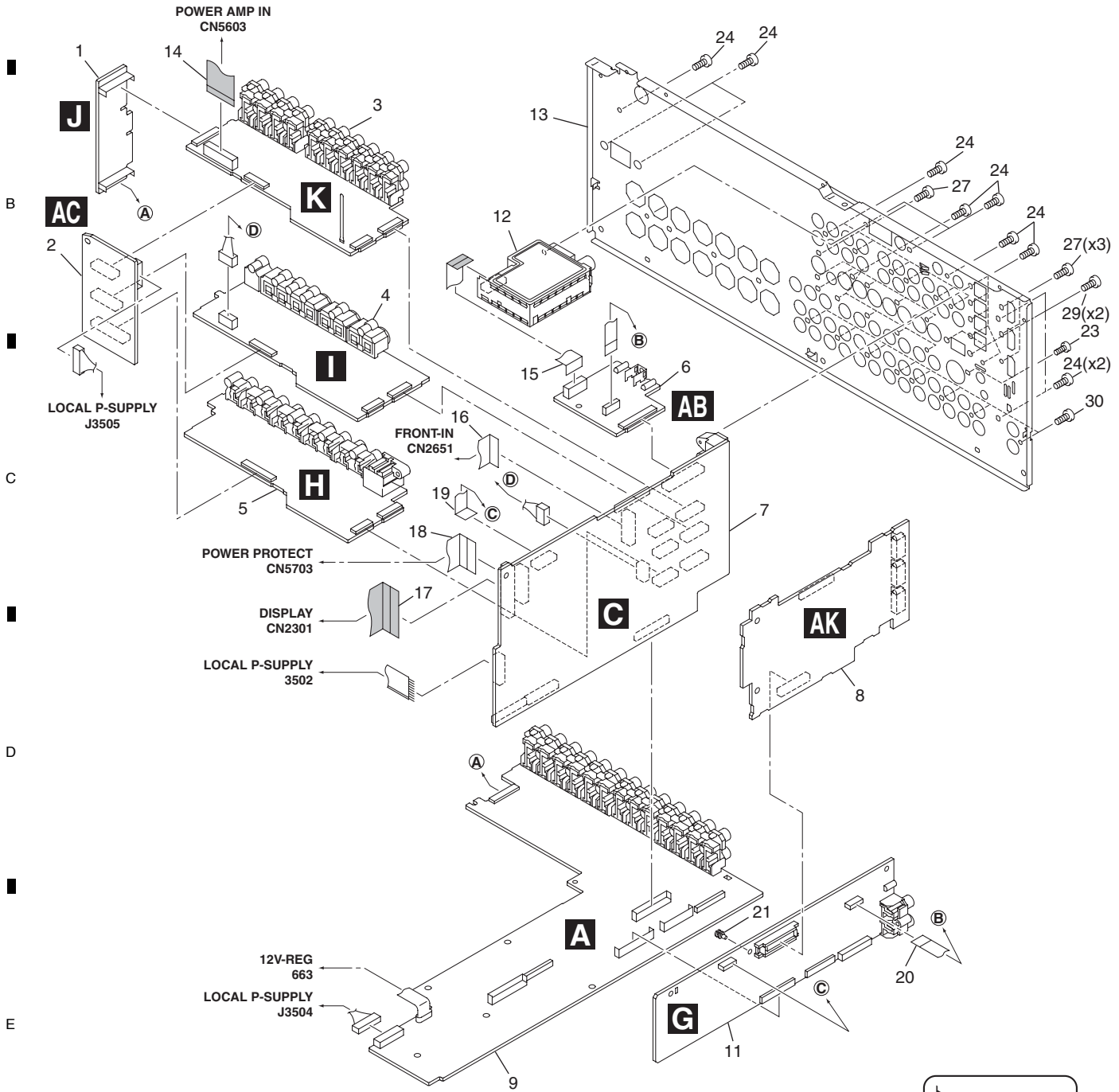

F

**(1) REAR SECTION PARTS LIST**

<u>Mark No.</u>	<u>Description</u>	<u>Part No.</u>	
1	BRIDGE 2 Assy	AWX8850	
2	VIDEO CONNECT Assy	AWX9069	A
3	COMPONENT Assy	AWX8847	
4	S-VIDEO Assy	AWX8844	
5	COMPOSITE Assy	AWX8841	
6	IR I/O Assy	AWX9066	
7	MAIN CONTROL Assy	AWX8816	
8	HDMI & DVC Assy	AWQ7040	
9	AUDIO IN Assy	AWX8820	
11	DSP Assy	AWX8813	
12	FM/AM Tuner Unit	AXX7250	B
13	Rear Panel 91KU	ANC8467	
13	Rear Panel 9120KKU	ANC8468	
14	19P FFC/60V (J58)	ADD7535	
15	11P FFC/60V (J59)	ADD7536	
16	17P FFC/60V (J54)	ADD7540	
17	29P FFC/60V (J55)	ADD7532	
18	19P FFC/60V (J56)	ADD7533	
19	12P FFC/60V (J52)	ADD7529	
20	10P FFC/60V (J51)	ADD7528	
21	Card Spacer	AEC7214	C
23	Screw	BBZ26P080FCC	
24	Screw	BBZ30P080FCC	
27	Screw	PMZ30P060FCC	
29	Screw 2.85 x 7	ABA7078	
30	Screw	BBT30P080FNI	

# 9.5 POWER AMP SECTION

1

2

3

4

A

B

C

D

E

F

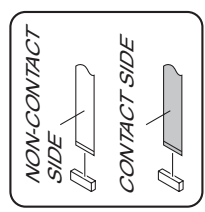
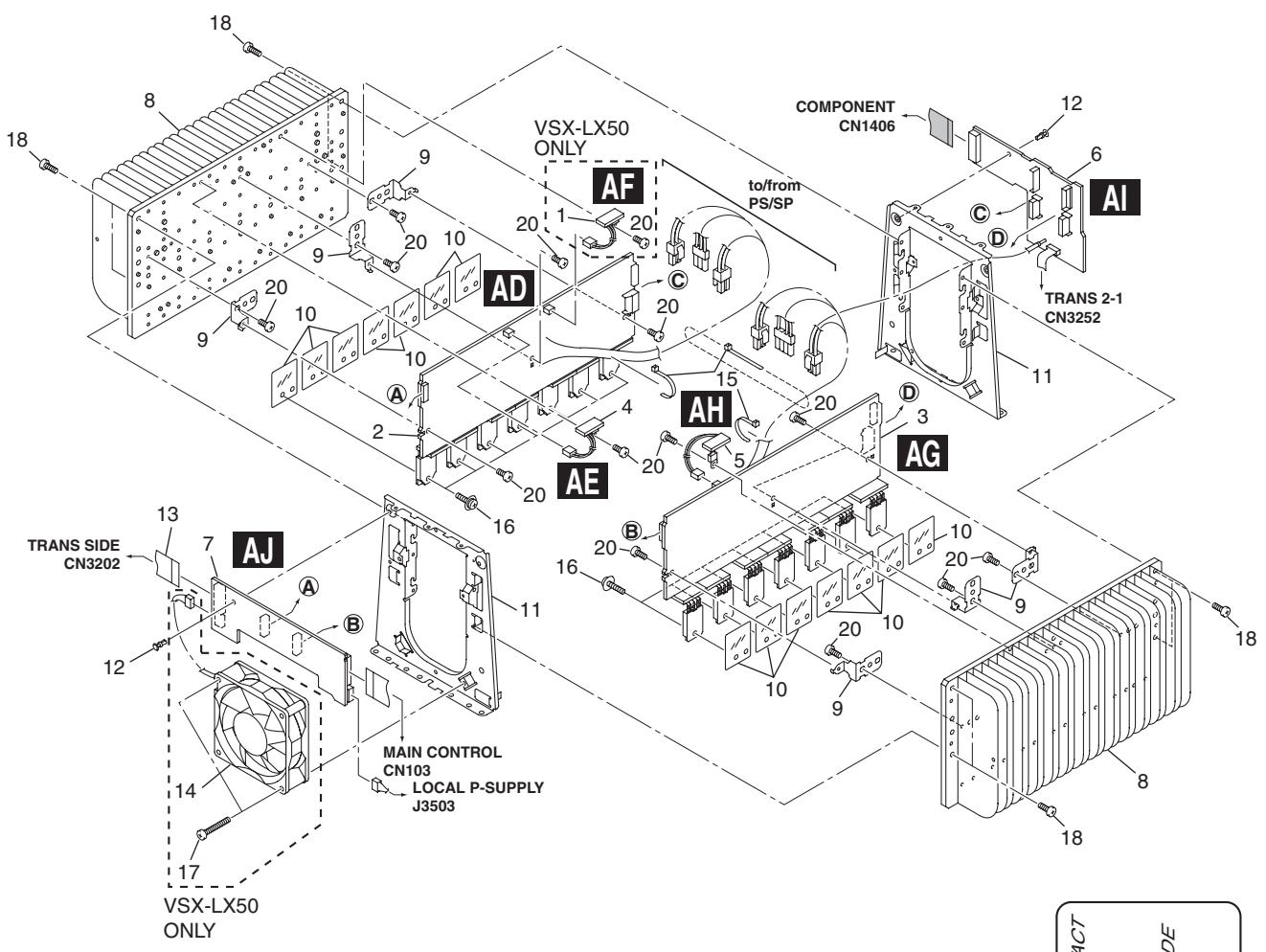

1

2

3

4

**(1) POWER AMP SECTION PARTS LIST**

<u>Mark No.</u>	<u>Description</u>	<u>Part No.</u>	<u>Mark No.</u>	<u>Description</u>	<u>Part No.</u>
1	POSI 2-L Assy	See Contrast table (2)	11	H.S. Angle 2016	ANG7547
2	POWER AMP-L Assy	See Contrast table (2)	12	Nyron Rivet	AEC7408
3	POWER AMP-R Assy	See Contrast table (2)	13	17P FFC/60V (J57)	ADD7534
4	POSI 1-L Assy	See Contrast table (2)	⚠ 14	DC Fan Motor	See Contrast table (2)
5	POSI 1-R Assy	See Contrast table (2)	NSP 15	Binder	ZCA-BK1
6	POWER AMP IN Assy	AWX9075	16	Screw 3X19	ABA7085
7	POWER PROTECT Assy	See Contrast table (2)	17	Screw	See Contrast table (2)
NSP 8	Heat Sink 45	ANH7152	18	Screw	BBT30P100FCC
9	PCB Angle 45	ANG7406	20	Screw	BBZ30P080FCC
10	Mica Sheet 45	AEE7047			

**(2) CONTRAST TABLE**

VSX-LX50/HYXJ5, VSX-91TXH/KUXJ/CA and VSX-9120TXH-K/KUXJ are constructed the same except for the following:

Mark	No.	Symbol and Description	VSX-LX50/ HYXJ5	VSX-91TXH/ KUXJ/CA	VSX-9120TXH-K/ KUXJ
	1	POSI 2-L Assy	AWX9082	Not used	Not used
	2	POWER AMP-L Assy	AWX9072	AWX9071	AWX9071
	3	POWER AMP-R Assy	AWX9073	AWX9106	AWX9106
	4	POSI 1-L Assy	AWX9081	AWX9080	AWX9080
	5	POSI 1-R Assy	AWX9084	AWX9083	AWX9083
	7	POWER PROTECT Assy	AWX9077	AWX9076	AWX9076
⚠	14	DC Fan Motor	AXM7029	Not used	Not used
	17	Screw	BBZ30P300FTC	Not used	Not used

# 9.6 FRONT PANEL SECTION

A  
B  
C  
D  
E  
F

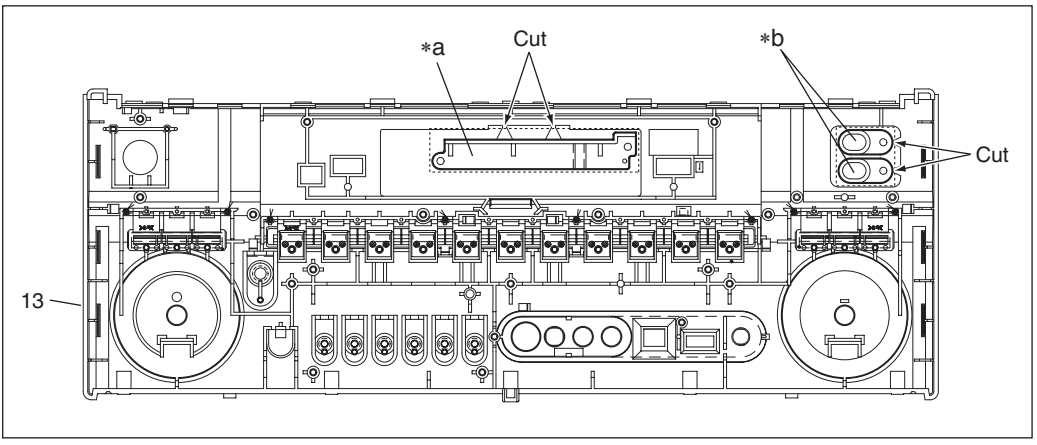
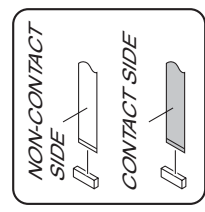
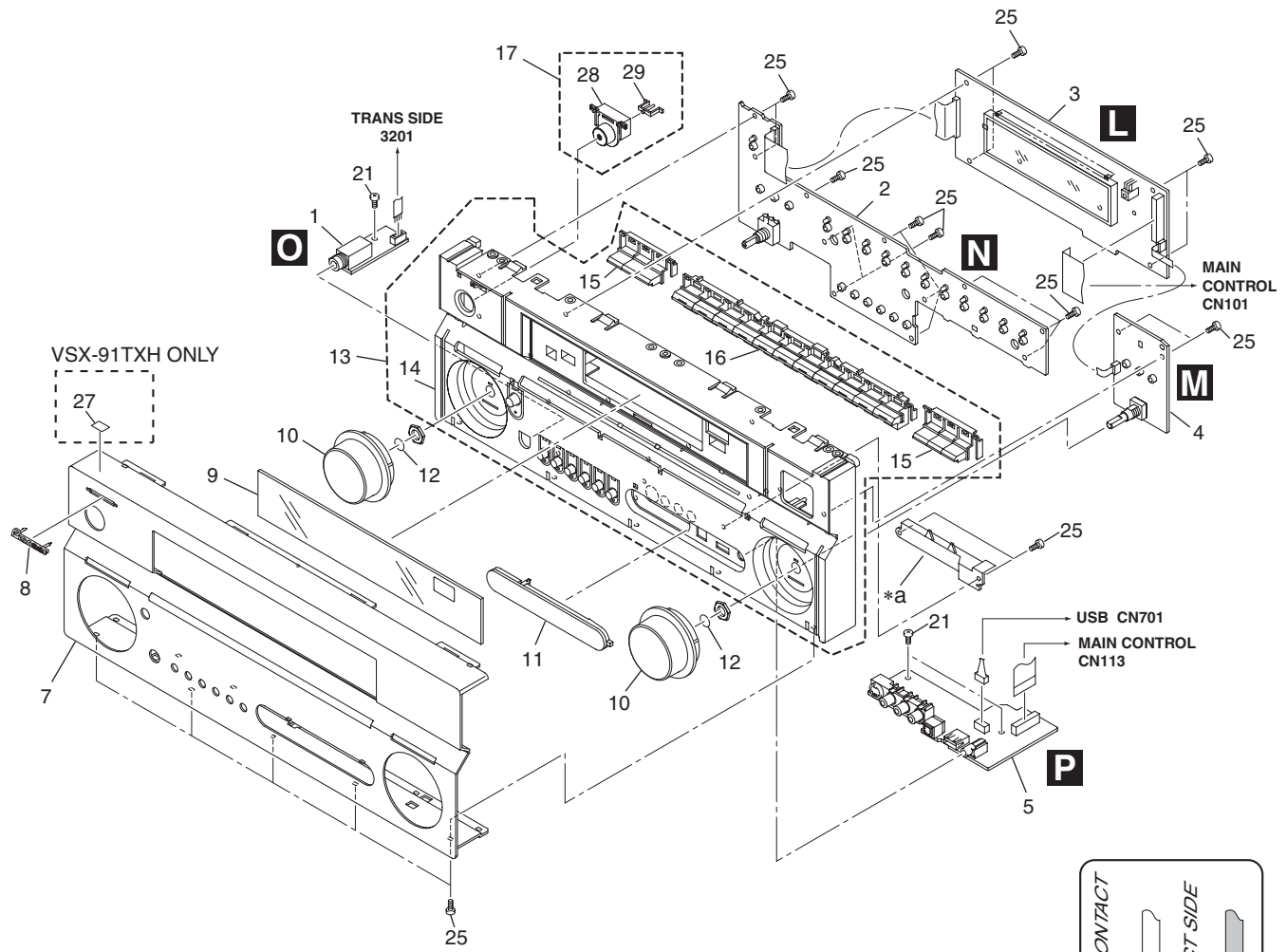

**(1) FRONT PANEL SECTION PARTS LIST**

<u>Mark No.</u>	<u>Description</u>	<u>Part No.</u>	<u>Mark No.</u>	<u>Description</u>	<u>Part No.</u>
1	HEADPHONE Assy	AWX9049	17	Standby BTN Assy	See Contrast table (2)
2	MULTI JOG Assy	See Contrast table (2)	21	Screw	BBZ30P080FCC
3	DISPLAY Assy	See Contrast table (2)	25	Screw	PPZ30P080FNI
4	VOLUME Assy	See Contrast table (2)	NSP 27	Energy Star Label	See Contrast table (2)
5	FRONT-IN Assy	See Contrast table (2)	28	Standby BTN	See Contrast table (2)
7	F Panel	See Contrast table (2)	NSP 29	Standby Lens V2	XAK3477
8	Pioneer Name Plate	See Contrast table (2)			
9	Window	See Contrast table (2)			
10	Vol. Knob	AAA7049			
11	Input Cover	See Contrast table (2)			
NSP 12	C Ring DIM 8.1	XBH3016			
13	P Base Assy	See Contrast table (2)			
NSP 14	P Base	See Contrast table (2)			
NSP 15	Side Button	AAD7761			
NSP 16	Func BTN Assy	AAD7758			

**(2) CONTRAST TABLE**

VSX-LX50/HYXJ5, VSX-91TXH/KUXJ/CA and VSX-9120TXH-K/KUXJ are constructed the same except for the following:

<u>Mark</u>	<u>No.</u>	<u>Symbol and Description</u>	<u>VSX-LX50/ HYXJ5</u>	<u>VSX-91TXH/ KUXJ/CA</u>	<u>VSX-9120TXH-K/ KUXJ</u>
	2	MULTI JOG Assy	AWX8880	AWX8879	AWX8879
	3	DISPLAY Assy	AWX8874	AWX8873	AWX8873
	4	VOLUME Assy	AWX9111	AWX9044	AWX9044
	5	FRONT-IN Assy	AWX8955	AWX8954	AWX8954
	7	F Panel LX50HY	ANB7415	Not used	Not used
	7	F Panel 91KU	Not used	ANB7413	Not used
	7	F Panel 9120KKU	Not used	Not used	ANB7414
	8	Pioneer Name Plate	AAM1107	VAM1109	XAM3006
	9	Window LX50HY	AAK8389	Not used	Not used
	9	Window 91KU	Not used	AAK8388	Not used
	9	Window 9120KU	Not used	Not used	AAK8387
	11	Input Cover LXHY	AAK8386	Not used	Not used
	11	Input Cover 81K	Not used	AAK8355	Not used
	13	P Base LX50HY Assy	AXG7336	Not used	Not used
	13	P Base 81KKU Assy	Not used	AXG7290	Not used
	13	P Base 9110KKU Assy	Not used	Not used	AXG7309
NSP	14	P Base 1016KPW	AMB7926	Not used	Not used
NSP	14	P Base 81KKU	Not used	AMB7919	Not used
NSP	14	P Base 9110KKU	Not used	Not used	AMB7921
	17	Standby BTN LXHY Assy	AAD7773	Not used	Not used
	17	Standby BTN 915K Assy	Not used	XAD3216	XAD3216
NSP	27	Energy Star Label	Not used	AAX8022	Not used
	28	Standby BTN LXHY	AAD7772	Not used	Not used
NSP	28	Standby BTN 915K	Not used	XAD3200	XAD3200

# 10. SCHEMATIC DIAGRAM

## 10.1 AUDIO IN ASSY (1/2)

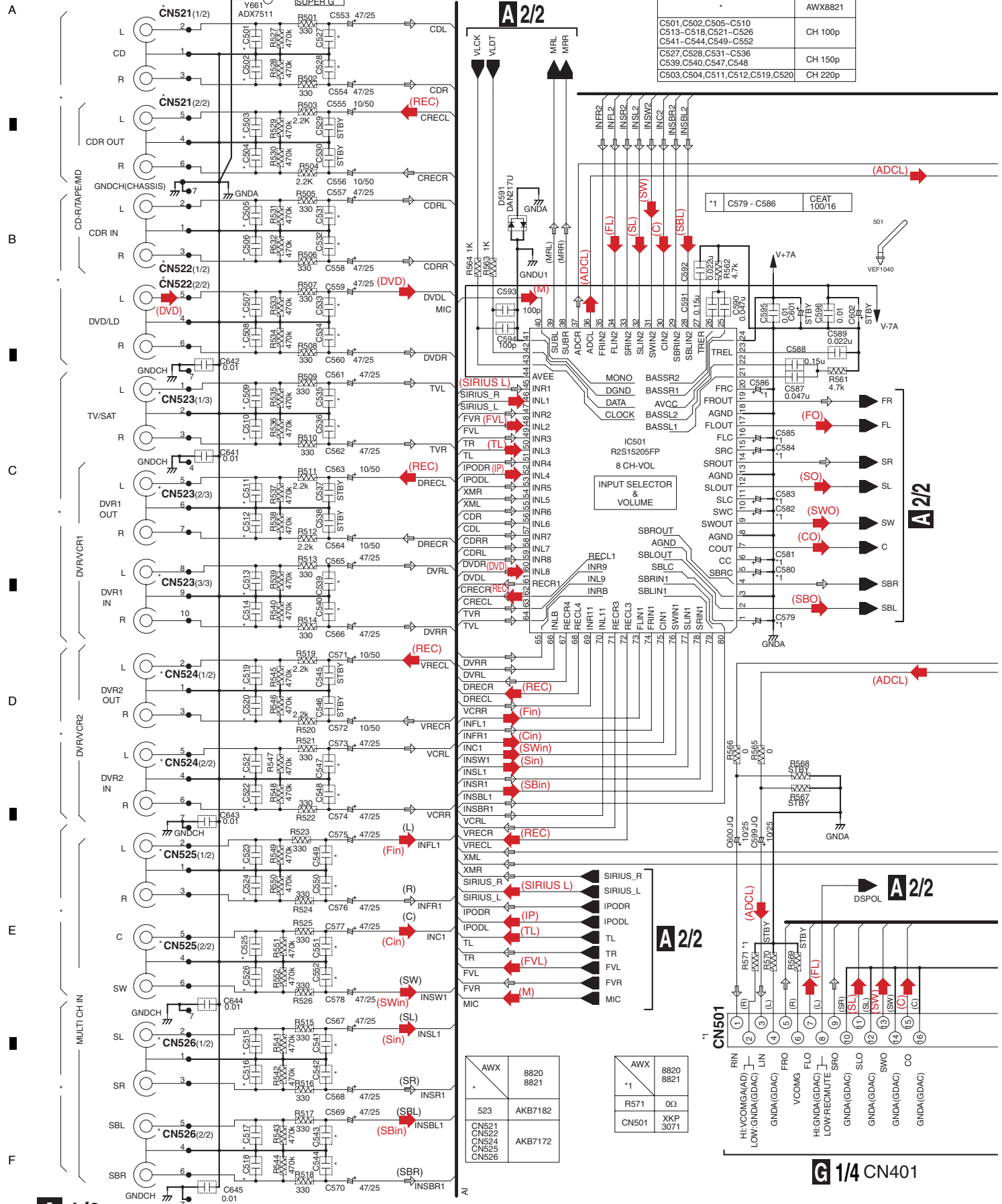

C501, C502, C505 - C510	AWX8821
C513 - C518, C521 - C526	CH 100p
C541 - C544, C549 - C552	
C527, C528, C531 - C536	CH 150p
C539, C540, C547, C548	
C503, C504, C511, C512, C519, C520	CH 220p

*1 C579 - C586	CEAT 100/16
----------------	-------------

AWX	8820
	8821
523	AKB7182
CN521	
CN522	
CN524	
CN525	
CN526	AKB7172

AWX	8820
	8821
*1	0Ω
R571	
CN501	XKP 3071

G 1/4 CN401

A 1/2

# A 1/2 AUDIO IN ASSY

(VSX-LX50 : AWX8821)  
 (VSX-91TXH, VSX-9120TXH : AWX8820)

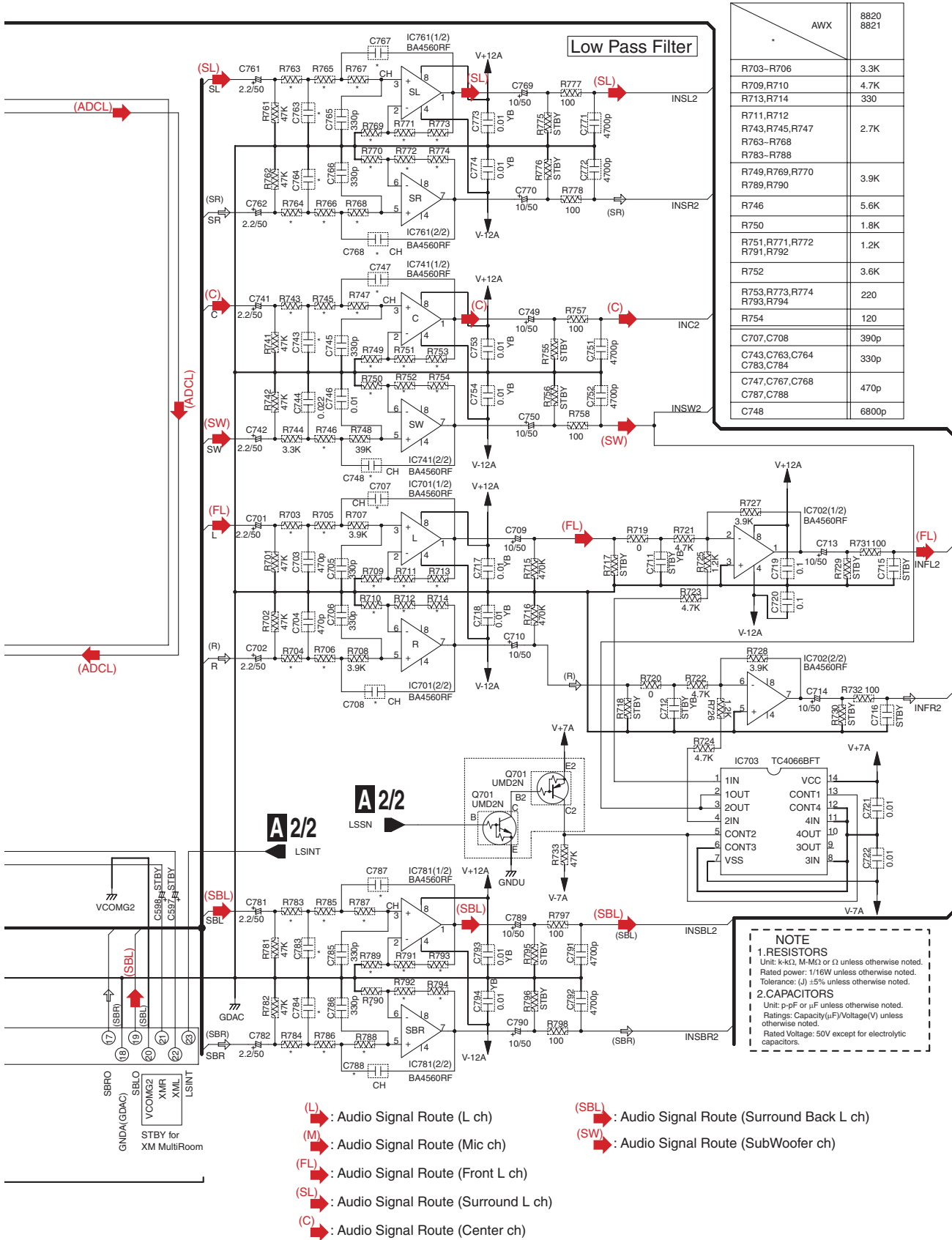

# 10.2 AUDIO IN (2/2) and 12V-REG ASSYS

A  
B  
C  
D  
E  
F

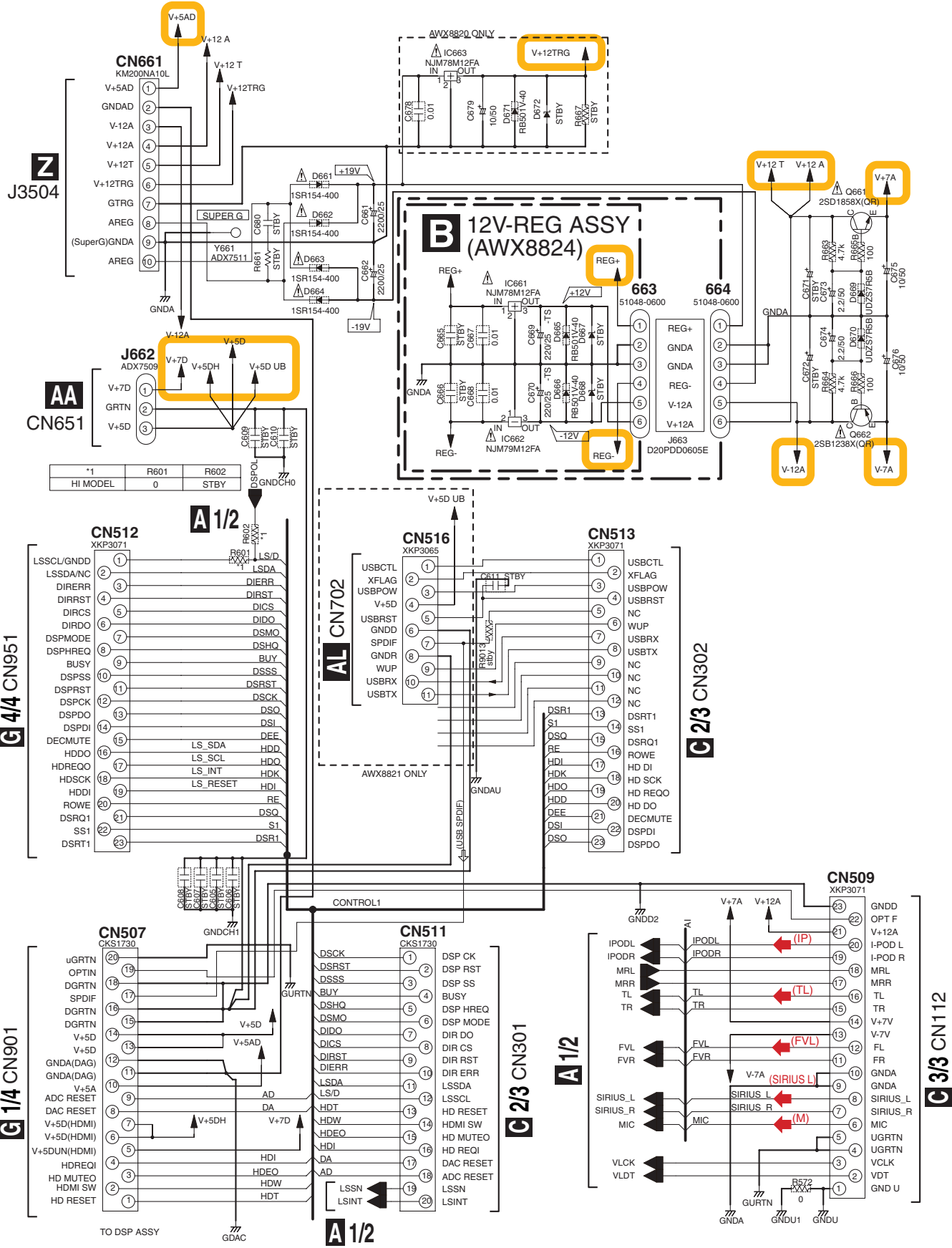

# A 2/2 AUDIO IN ASSY

(VSX-LX50 : AWX8820)  
(VSX-91TXH, VSX-9120TXH : AWX8820)

HIGH	
91TXH/KUCA	AWX8820
9120TXH/KUCA	AWX8820
LX50/HY	AWX8821

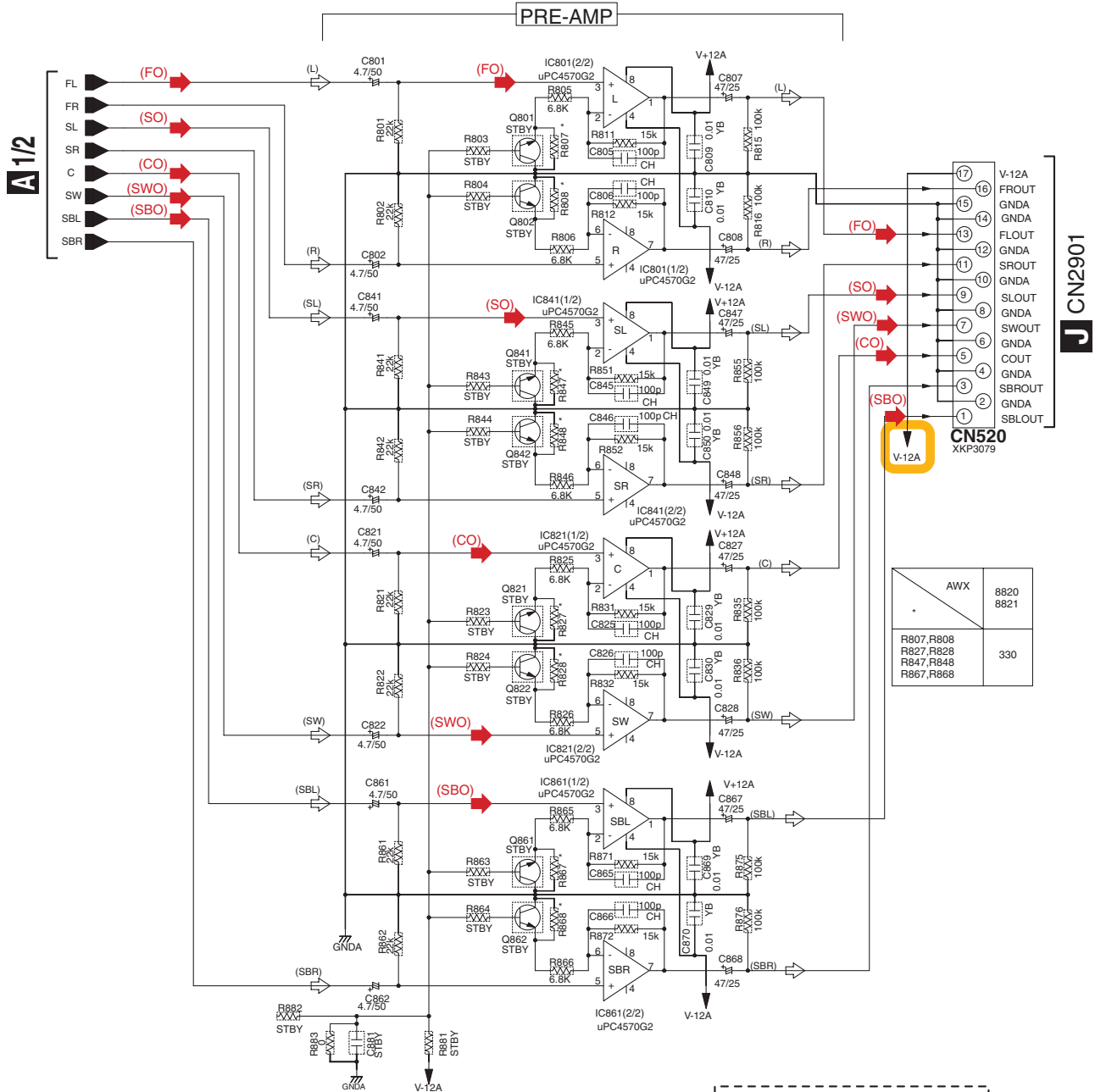

AWX	
.	8820 8821
R807, R808 R827, R828 R847, R848 R867, R868	330

- (L) : Audio Signal Route (L ch)
- (M) : Audio Signal Route (Mic ch)
- (FL) : Audio Signal Route (Front L ch)
- (SL) : Audio Signal Route (Surround L ch)
- (C) : Audio Signal Route (Center ch)
- (SBL) : Audio Signal Route (Surround Back L ch)
- (SW) : Audio Signal Route (SubWoofer ch)

**NOTE**

**1.RESISTORS**  
Unit: k-k $\Omega$ , M-M $\Omega$  or  $\Omega$  unless otherwise noted.  
Rated power: 1/16W unless otherwise noted.  
Tolerance: (J)  $\pm$ 5% unless otherwise noted.

**2.CAPACITORS**  
Unit: p-pF or  $\mu$ F unless otherwise noted.  
Ratings: Capacity( $\mu$ F)/Voltage(V) unless otherwise noted.  
Rated Voltage: 50V except for electrolytic capacitors.



# AJ CN5703

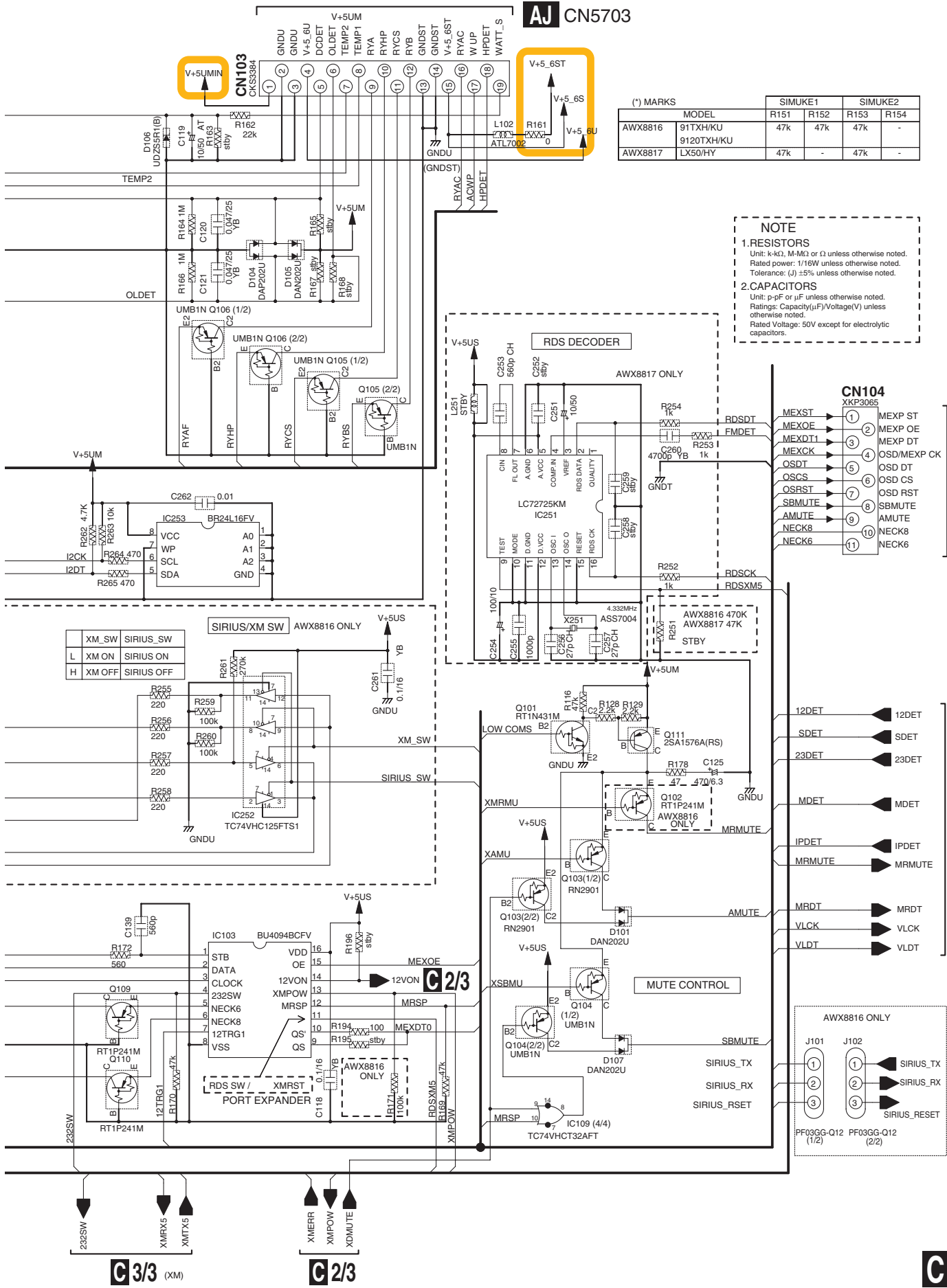

# 10.4 MAIN CONTROL (2/3), GUARD-C and GUARD-F ASSYS

## C2/3 MAIN CONTROL ASSY (VSX-LX50 : AWX8817) (VSX-91TXH, VSX-9120TXH : AWX8816)

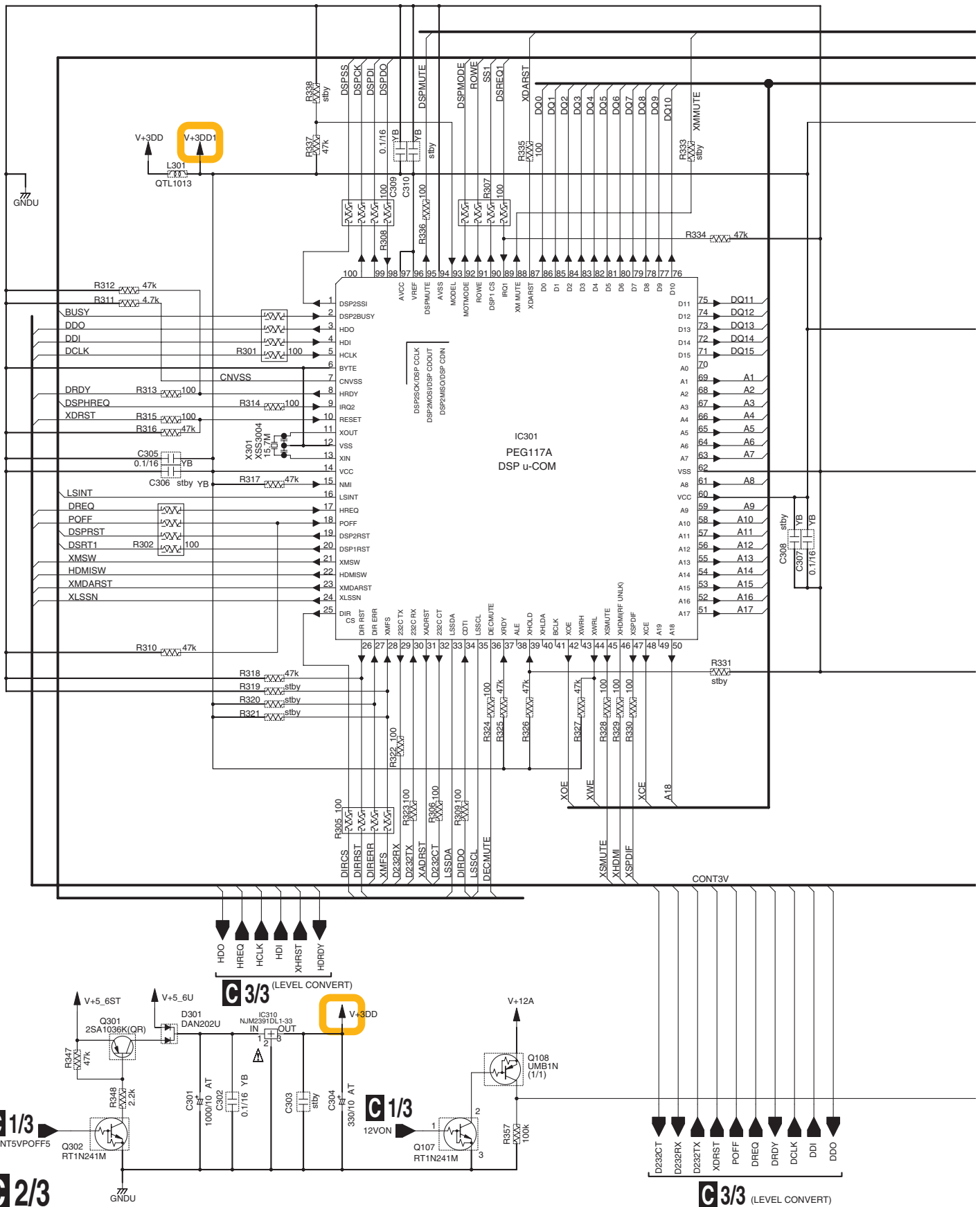

**D** GUARD-C ASSY (AWX8826)      **E** GUARD-F ASSY (AWX8825)

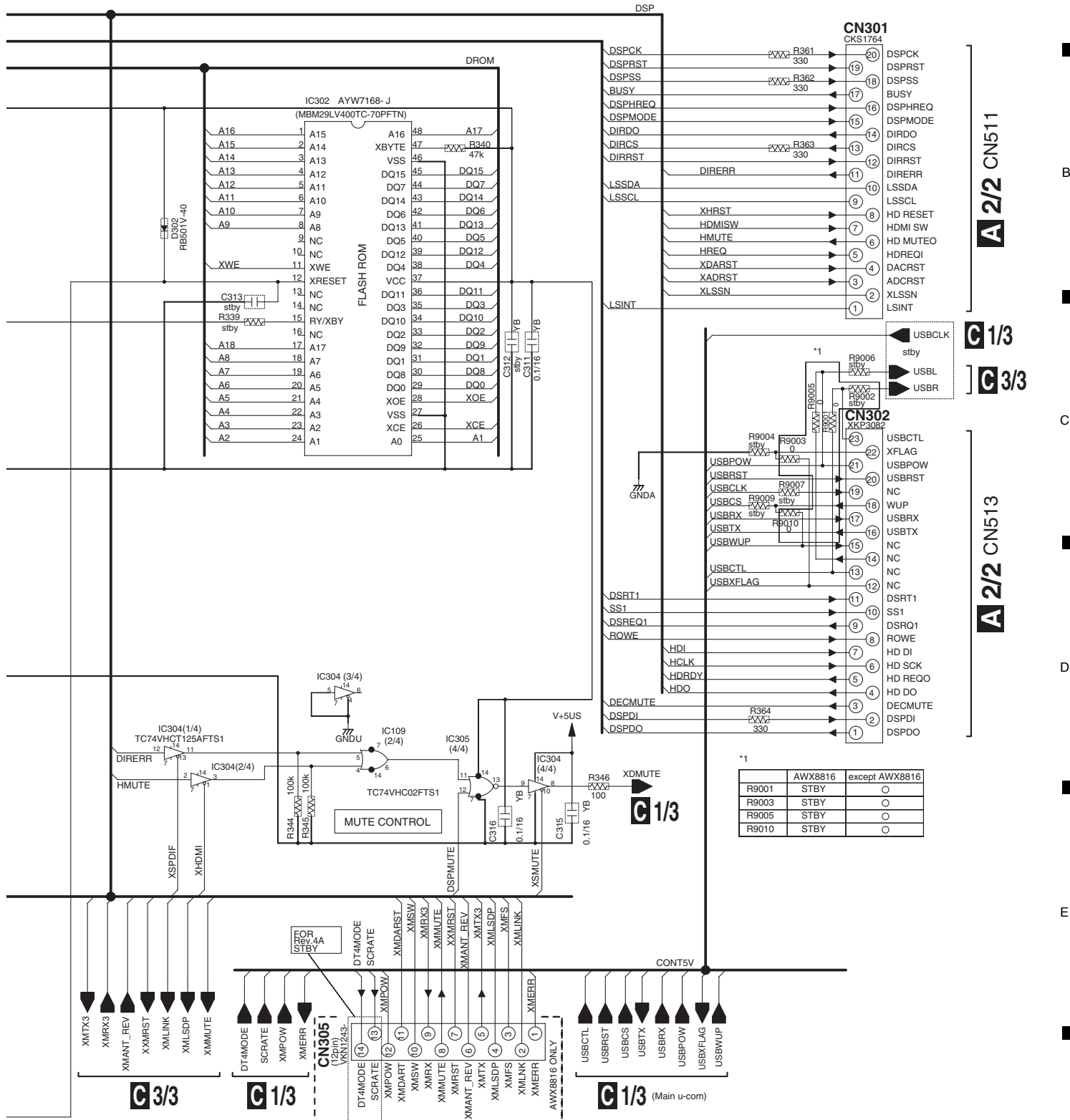
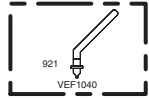
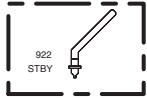

	AWX8816	except AWX8816
R9001	STBY	○
R9003	STBY	○
R9005	STBY	○
R9010	STBY	○

**NOTE**  
**1.RESISTORS**  
 Unit: k-kΩ, M-MΩ or Ω unless otherwise noted.  
 Rated power: 1/16W unless otherwise noted.  
 Tolerance: (J) ±5% unless otherwise noted.  
**2.CAPACITORS**  
 Unit: p-pF or μF unless otherwise noted.  
 Ratings: Capacity(μF)/Voltage(V) unless otherwise noted.  
 Rated Voltage: 50V except for electrolytic capacitors.

**G 4/4** CN953

**C 2/3**



C1/3

C3/3

MAIN CONTROL ASSY  
(VSX-LX50 : AWX8817)

(VSX-91TXH, VSX-9120TXH : AWX8816)

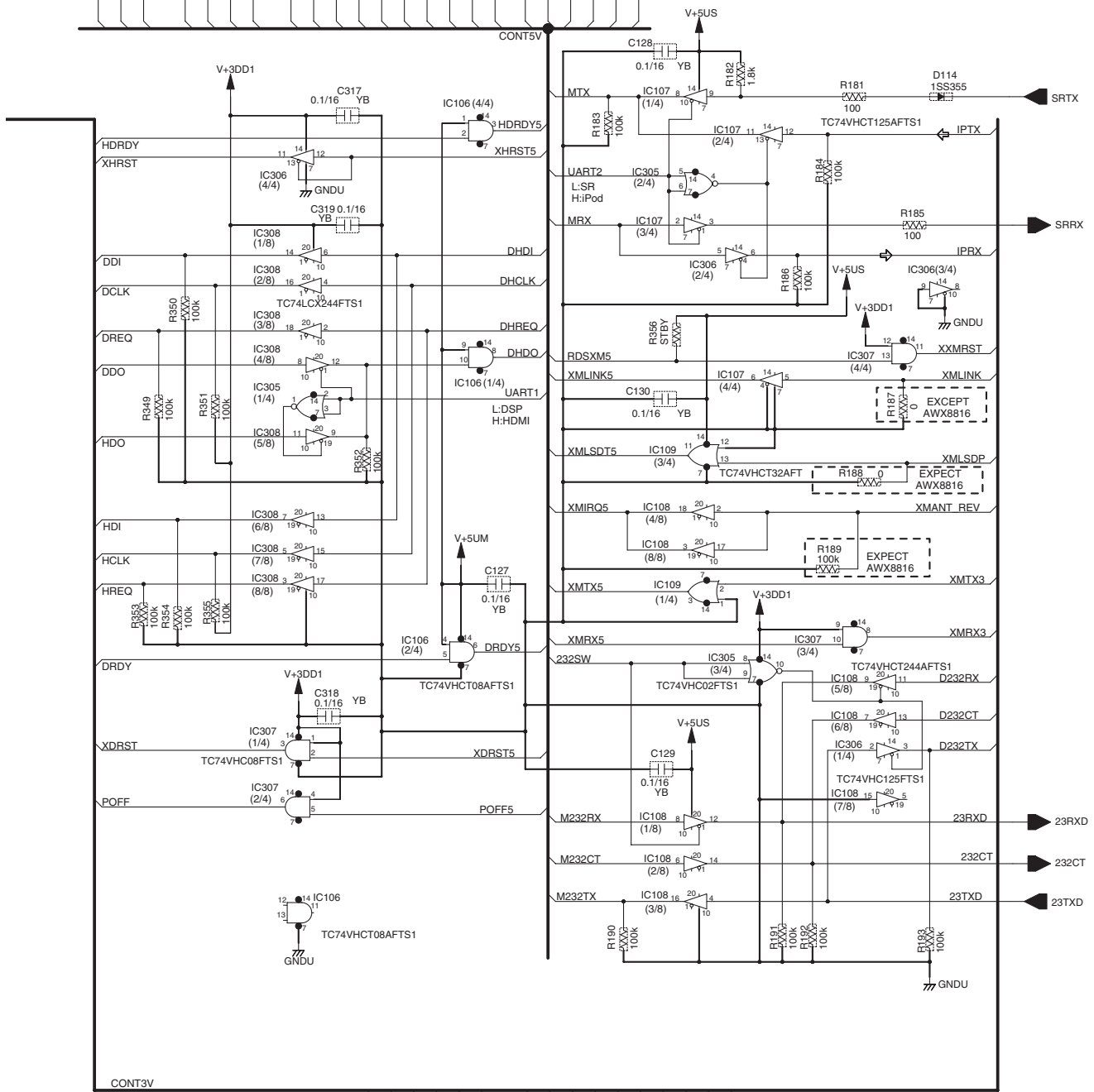

**NOTE**  
 1. RESISTORS  
 Unit: k-Ω, M-Ω or Ω unless otherwise noted.  
 Rated power: 1/16W unless otherwise noted.  
 Tolerance: (J) ±5% unless otherwise noted.  
 2. CAPACITORS  
 Unit: p-pF or μF unless otherwise noted.  
 Ratings: Capacity (μF) / Voltage (V) unless otherwise noted.  
 Rated Voltage: 50V except for electrolytic capacitors.

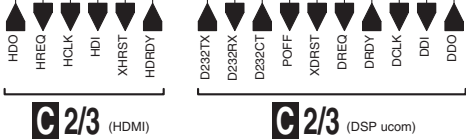
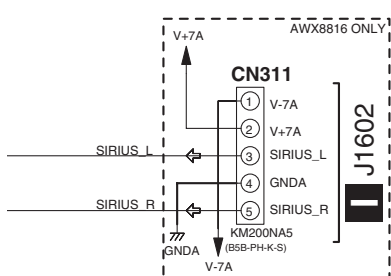

- (L) : Audio Signal Route (L ch)
- (M) : Audio Signal Route (Mic ch)
- (D) : Audio Data Route
- (V) : Video Signal Route
- (SY) : S-Video Signal Route (Y ch)
- (SC) : S-Video Signal Route (C ch)

VSX-LX50

C3/3

# 10.6 DSP ASSY (1/4)

**G 1/4** DSP ASSY (VSX-LX50 : AWX8814) (VSX-91TXH, VSX-9120TXH : AWX8813)

A  
B  
C  
D  
E  
F

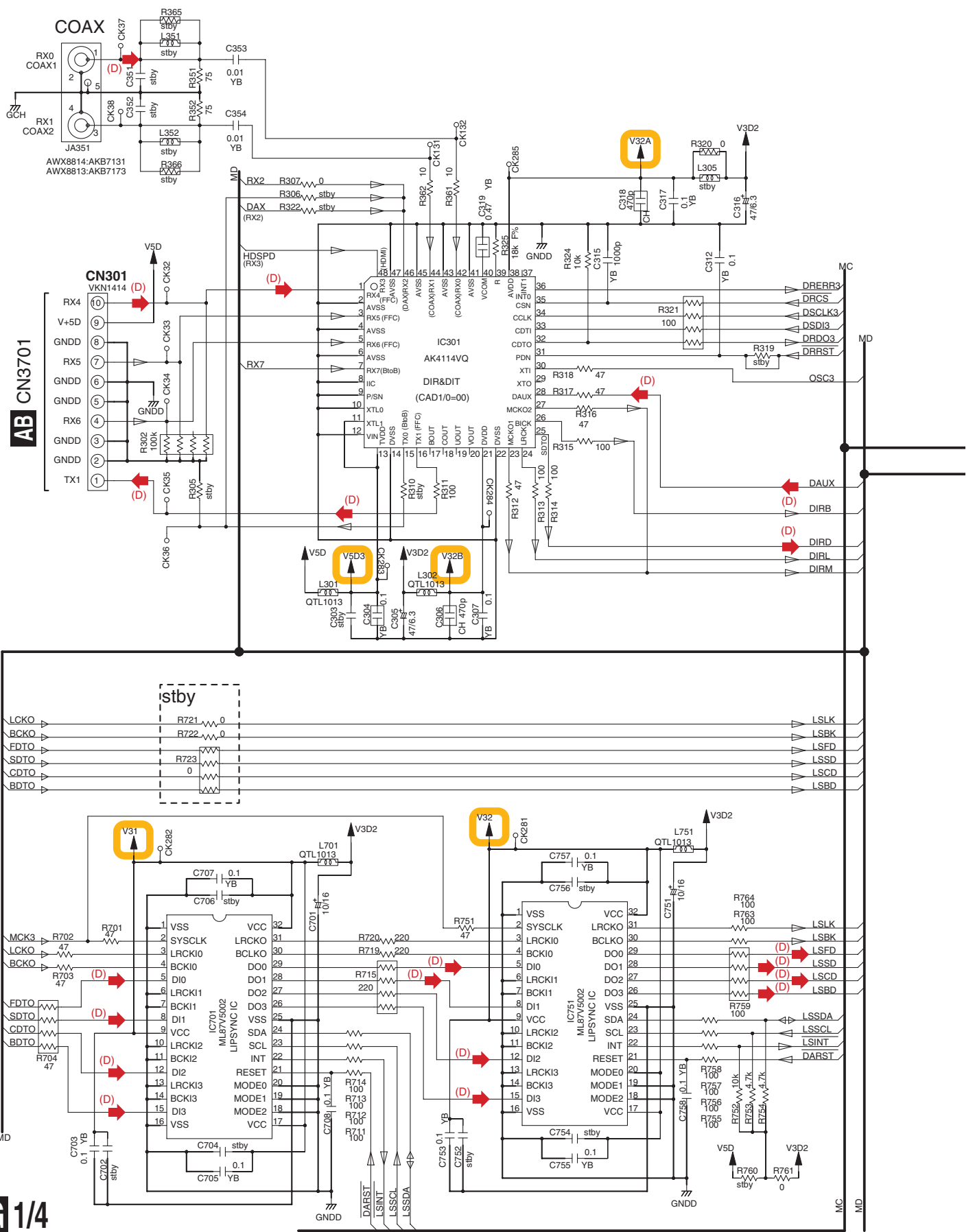

**G 1/4**

# G 2/4 - 4/4

- (D) : Audio Data Route
- (L) : Audio Signal Route (L ch)
- (FL) : Audio Signal Route (Front L ch)
- (SL) : Audio Signal Route (Surround L ch)
- (C) : Audio Signal Route (Center ch)
- (SBL) : Audio Signal Route (Surround Back L ch)
- (SW) : Audio Signal Route (Subwoofer ch)

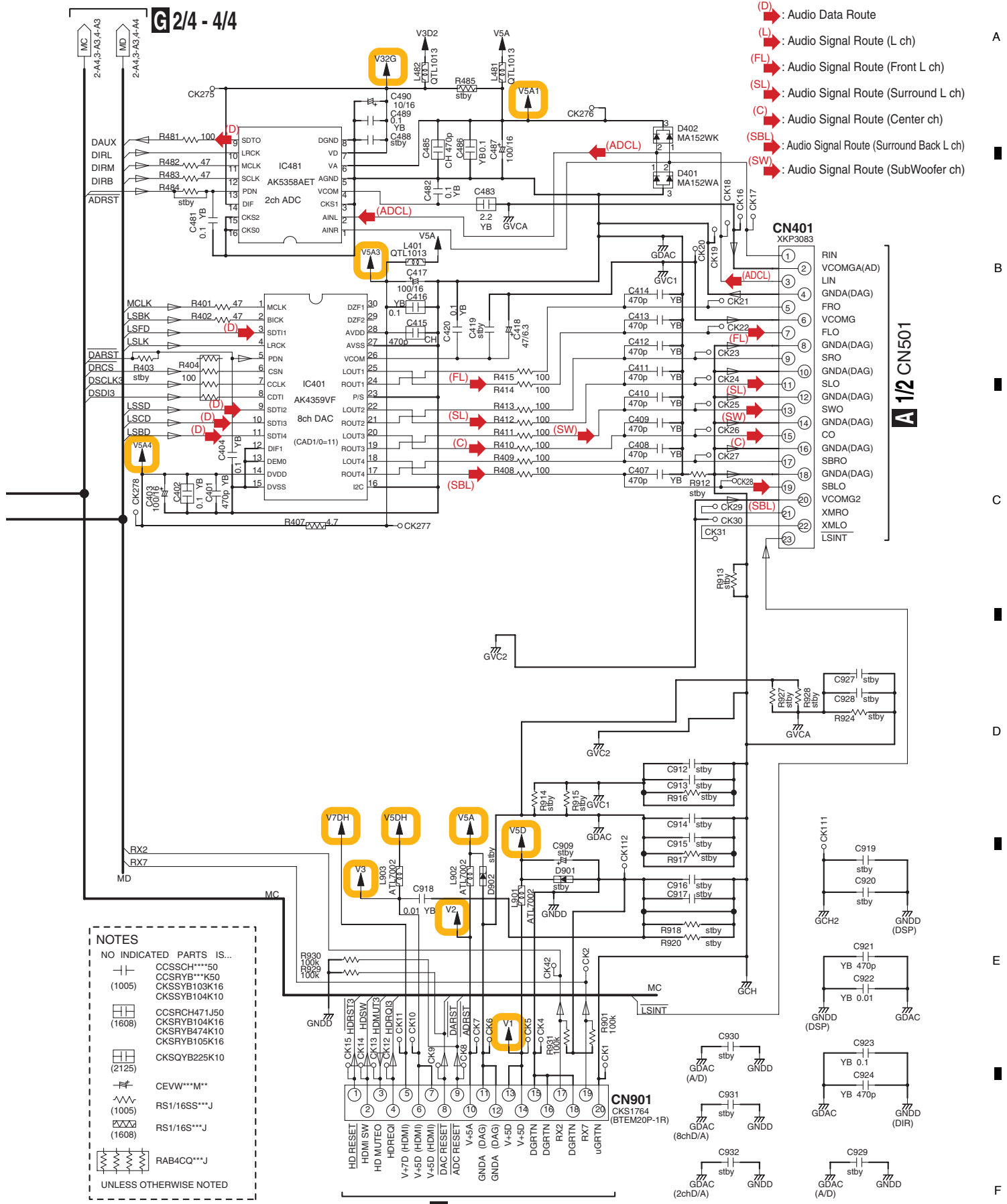

# A 1/2 CN501

**NOTES**

NO INDICATED PARTS IS...

- CCSSCH\*\*\*50
- CCSSRYB\*\*\*K50
- (1005) CKSSYB103K16
- CKSSYB104K10
- CCSRCH471J50
- CKSRYB104K16
- CKSRYB474K10
- CKSRYB105K16
- CKSQYB225K10
- (2125)
- CEVW\*\*\*M\*\*
- RS1/16SS\*\*\*J
- (1005)
- RS1/16S\*\*\*J
- (1608)
- RAB4CO\*\*\*J

UNLESS OTHERWISE NOTED

# A 2/2 CN507

# G 1/4

# VSX-LX50

# 10.7 DSP ASSY (2/4)

A

B

C

D

E

F

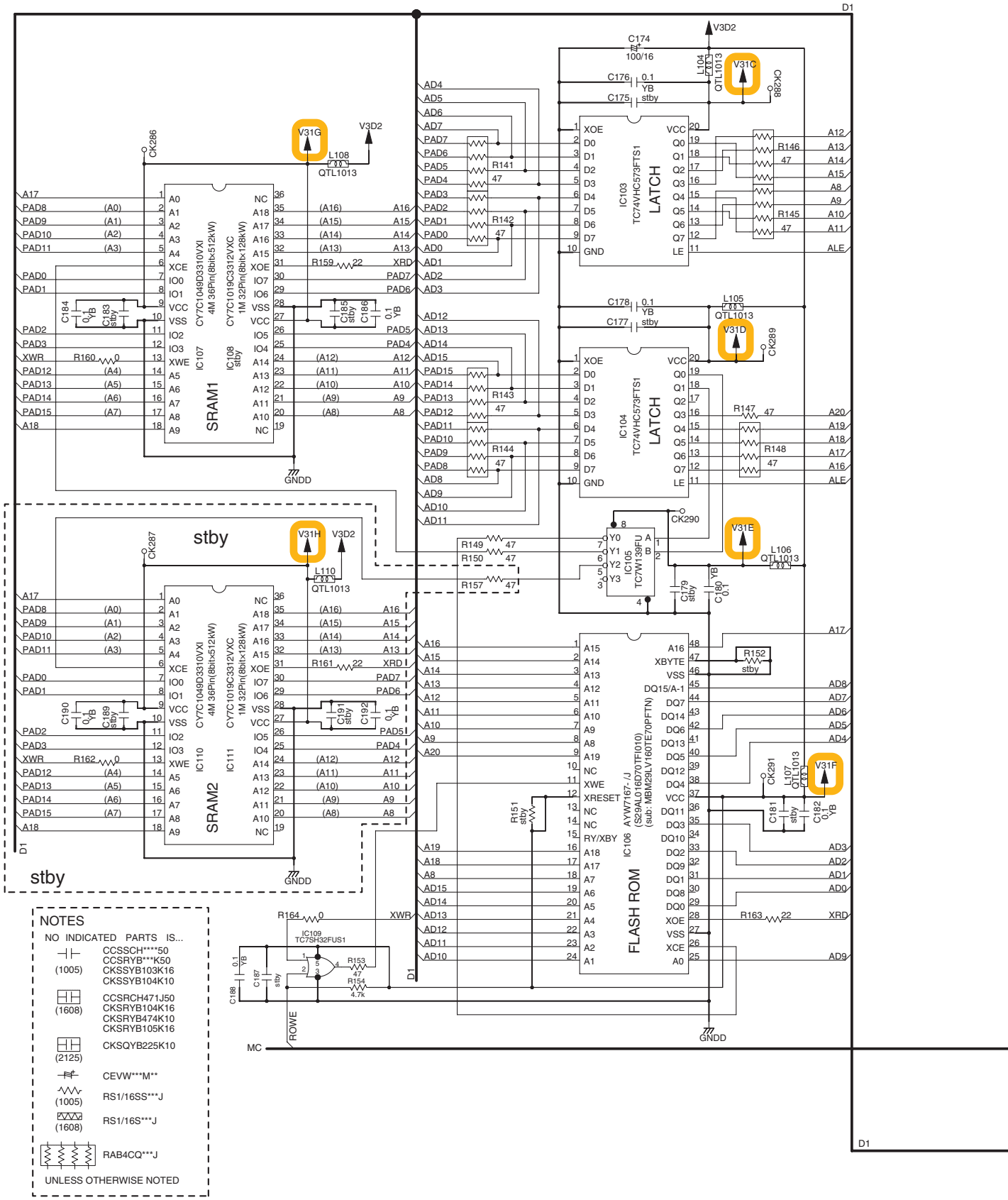

- NOTES**
- NO INDICATED PARTS IS...
    - CCSSCH\*\*\*50
    - CCSRYB\*\*\*K50
    - CKSSYB103K16
    - CKSSYB104K10
    - CCSRCH471J50
    - CKSRYB104K16
    - CKSRYB474K10
    - CKSRYB105K16
    - CKSQYB225K10
  - CEVW\*\*\*M\*\*
  - RS1/16SS\*\*\*J
  - RS1/16S\*\*\*J
  - RAB4CQ\*\*\*J
- UNLESS OTHERWISE NOTED

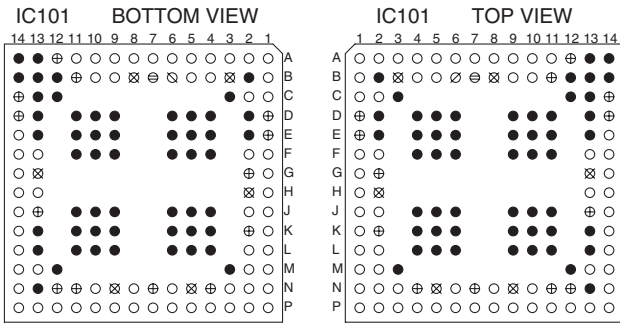

**G 2/4 DSP ASSY**  
 (VSX-LX50 : AWX8814)  
 (VSX-91TXH, VSX-9120TXH : AWX8813)

- ⊕ VDDINT
- ⊗ VVDEXT
- GND
- AVSS
- ⊖ AVDD
- I/O SIGNALS

**(D)** : Audio Data Route

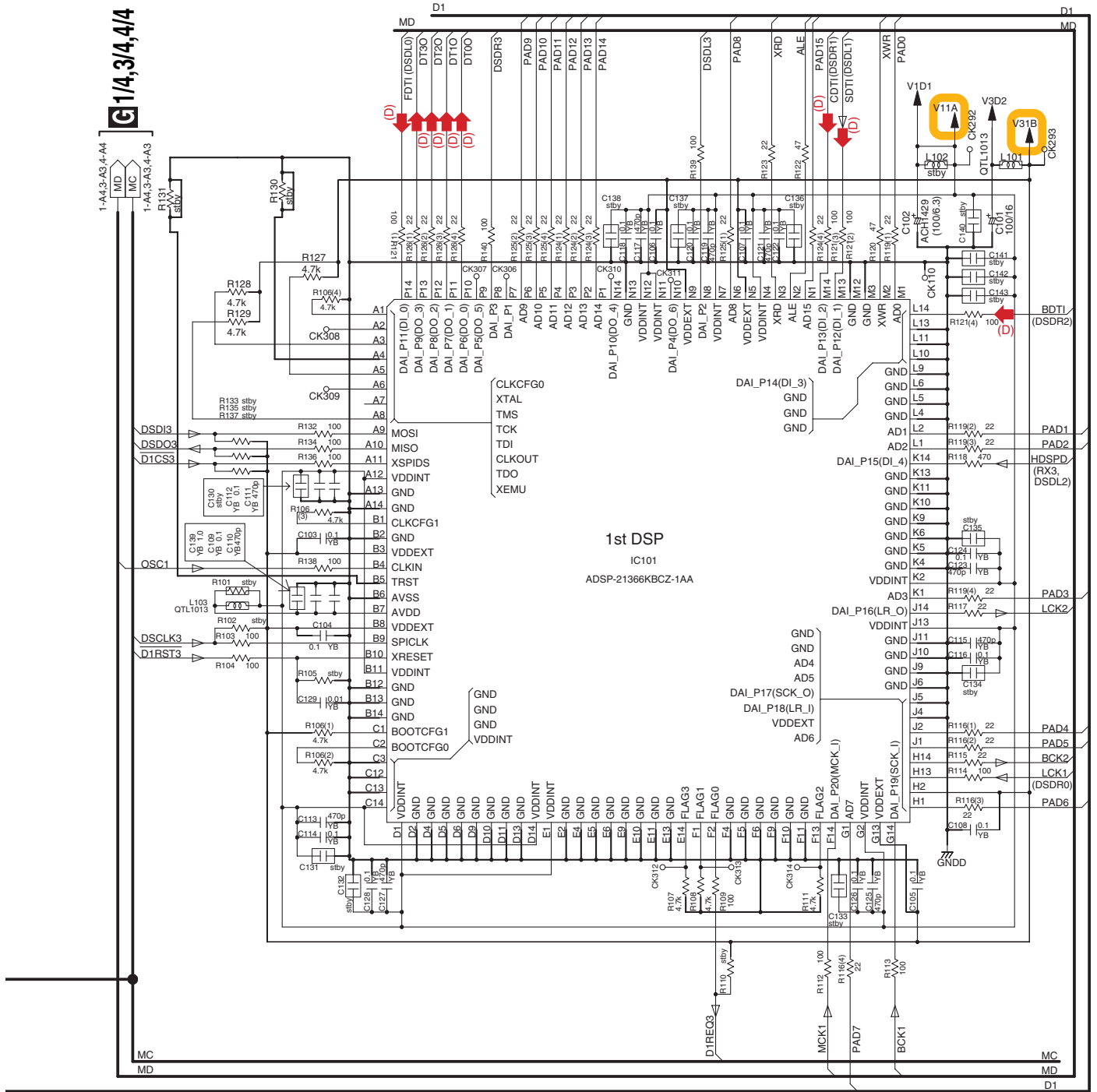

# 10.8 DSP ASSY (3/4)

**G 3/4** DSP ASSY (VSX-LX50 : AWX8814)  
(VSX-91TXH, VSX-9120TXH : AWX8813)

**G 1/4, 2/4, 4/4**

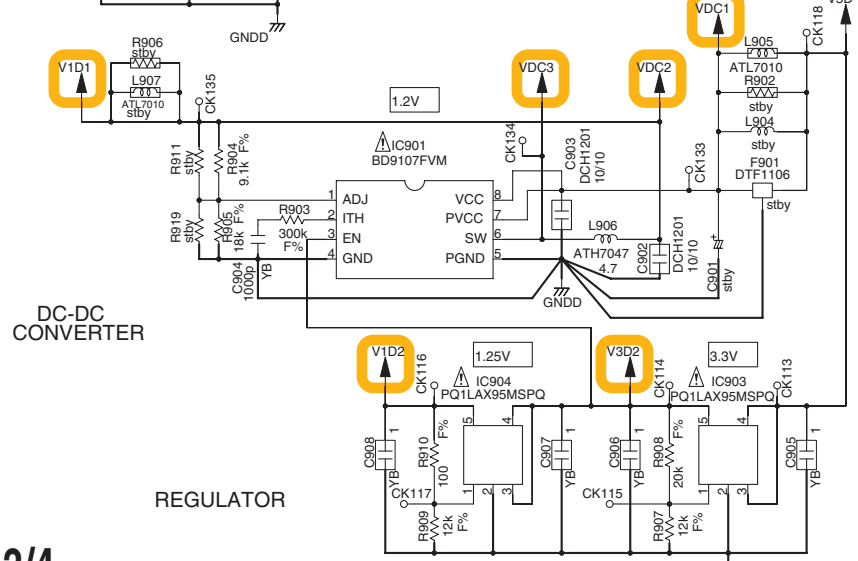
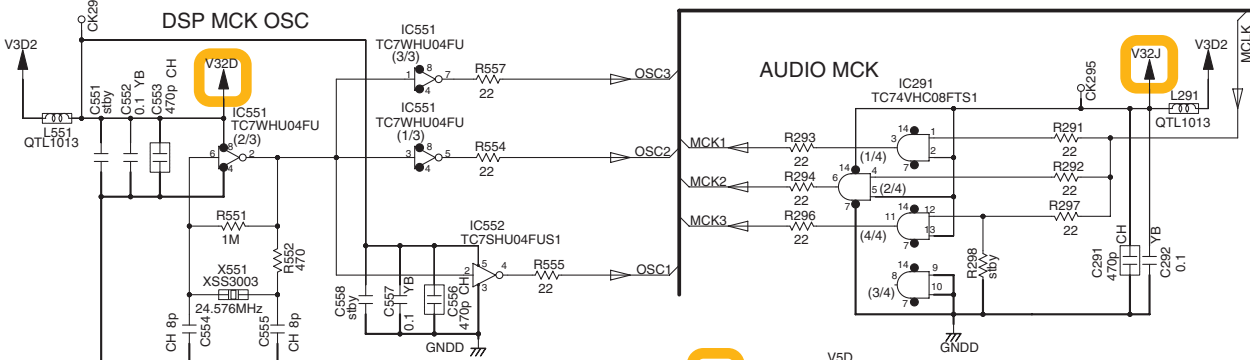
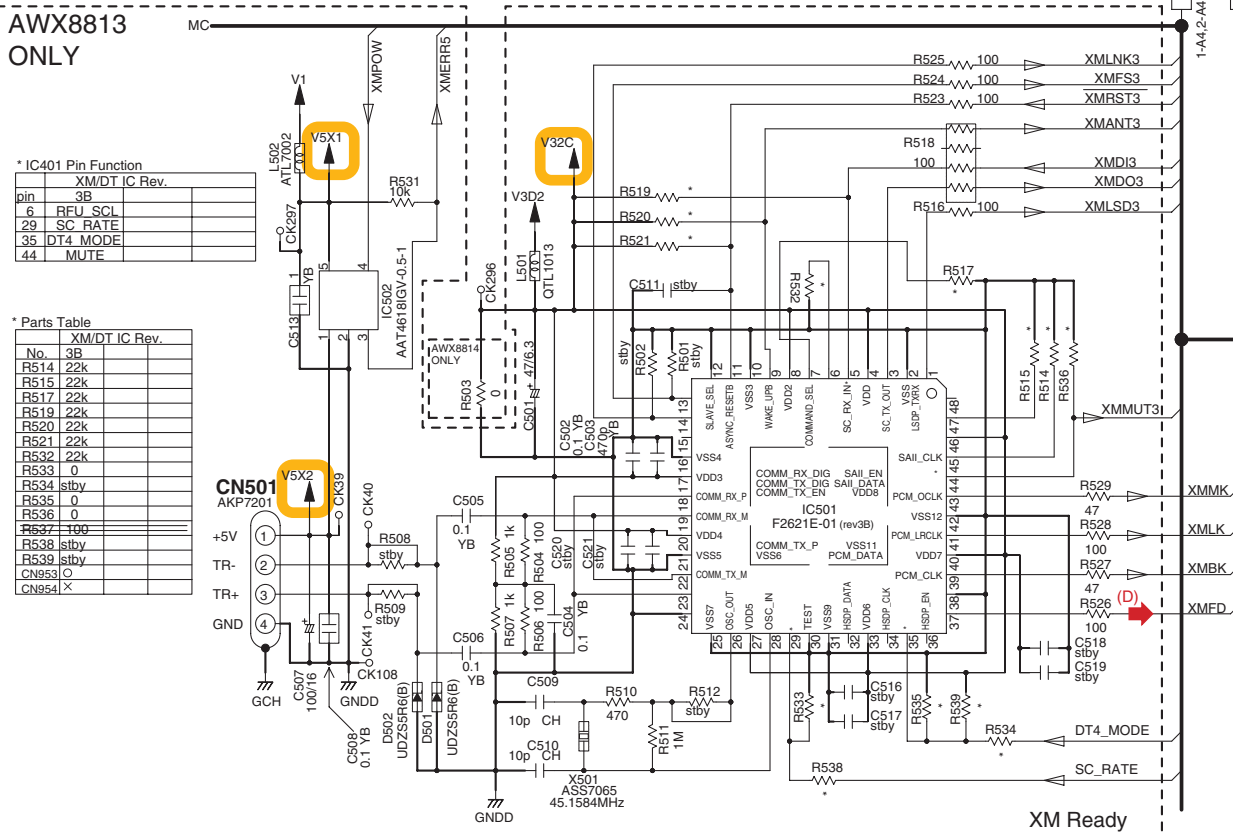

- NOTES**
- NO INDICATED PARTS IS...
    - CCSSCH\*\*\*50
    - CCSRYP\*\*\*K50
    - CKSSYB103K16
    - CKSSYB104K10
    - CCSRCH471J50
    - CKSRYP104K16
    - CKSRYP474K10
    - CKSRYP105K16
    - CKSQYB225K10
    - CEVW\*\*\*M\*\*
    - RS1/16SS\*\*\*J
    - RS1/16S\*\*\*J
    - RAB4CQ\*\*\*J
  - UNLESS OTHERWISE NOTED

**G 3/4**

(D) : Audio Data Route

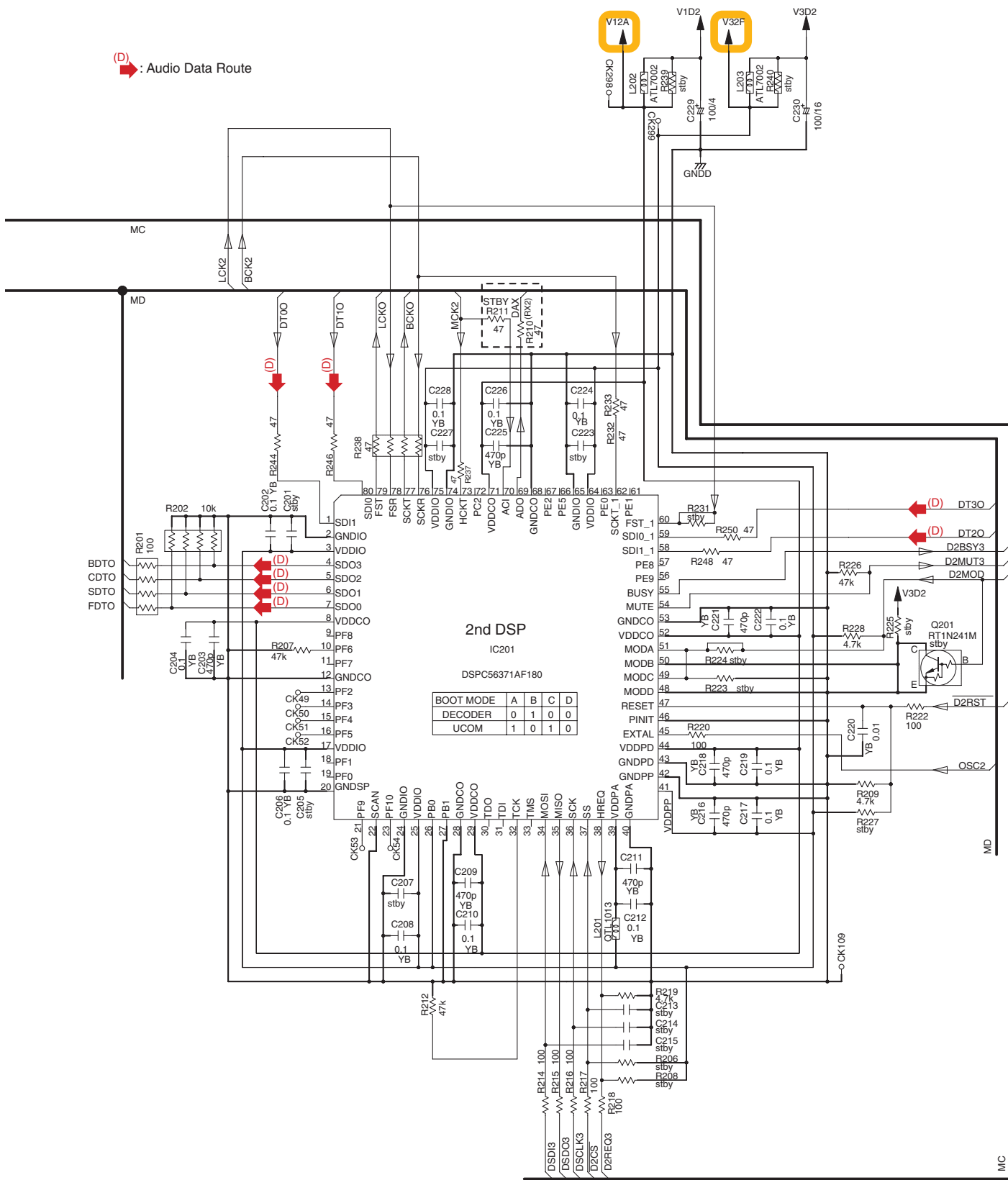

# 10.9 DSP ASSY (4/4)

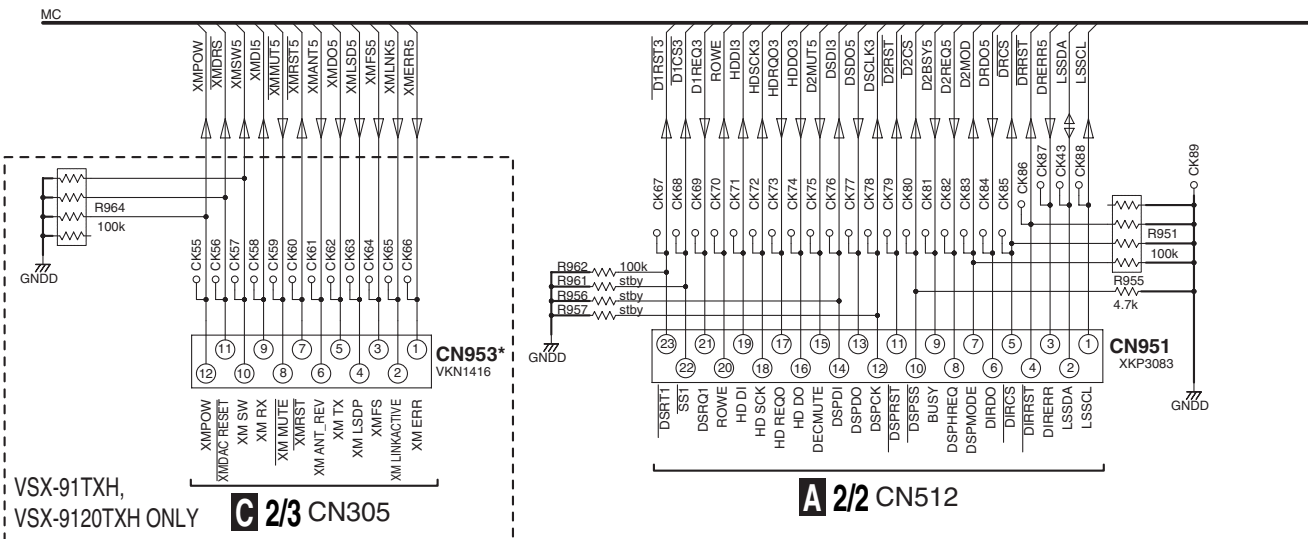
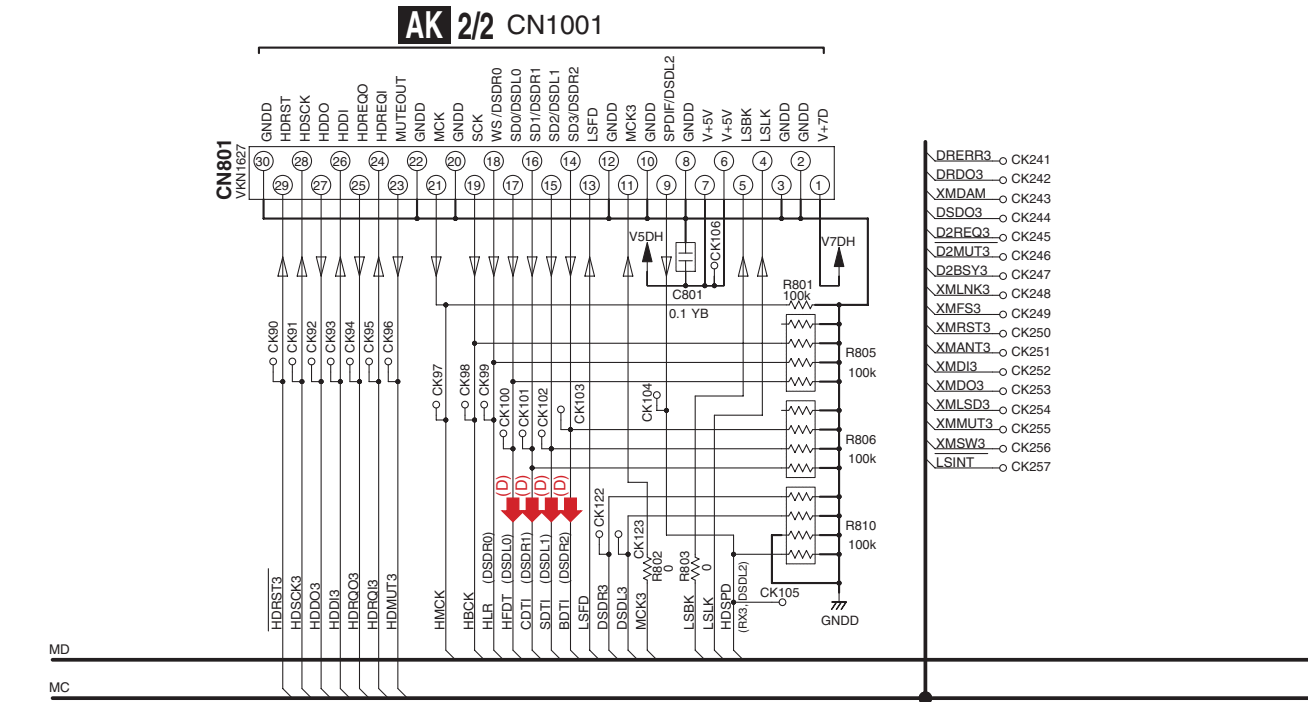

# G1/4 - 3/4

# G4/4 DSP ASSY (VSX-LX50 : AWX8814) (VSX-91TXH, VSX-9120TXH : AWX8813)

(D) : Audio Data Route

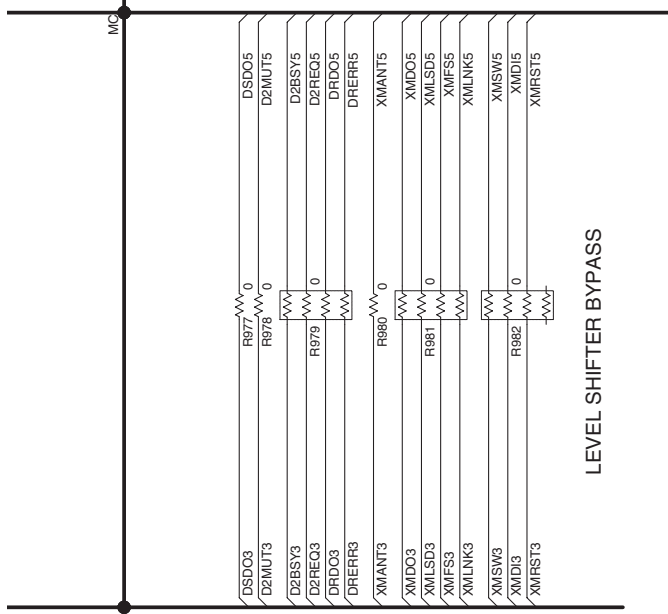
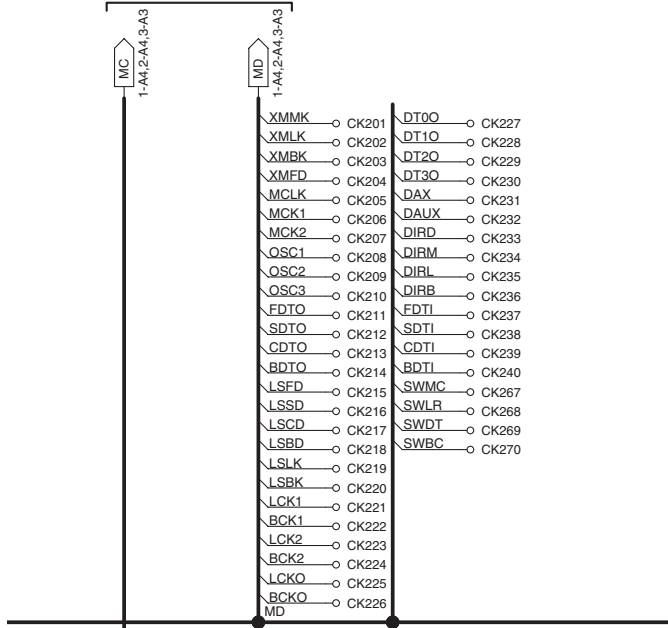

- NOTES**
- NO INDICATED PARTS IS...
    - CCSCH\*\*\*50
    - CCSRYB\*\*\*K50
    - (1005)
    - CKSSYB103K16
    - CKSSYB104K10
  - CCSRCH471J50
  - CKSRYB104K16
  - CKSRYB474K10
  - CKSRYB105K16
  - CKSRYB225K10
  - (2125)
  - CEW\*\*\*M\*\*
  - RS1/16SS\*\*\*J
  - (1005)
  - RS1/16S\*\*\*J
  - (1608)
  - RAB4CO\*\*\*J
- UNLESS OTHERWISE NOTED

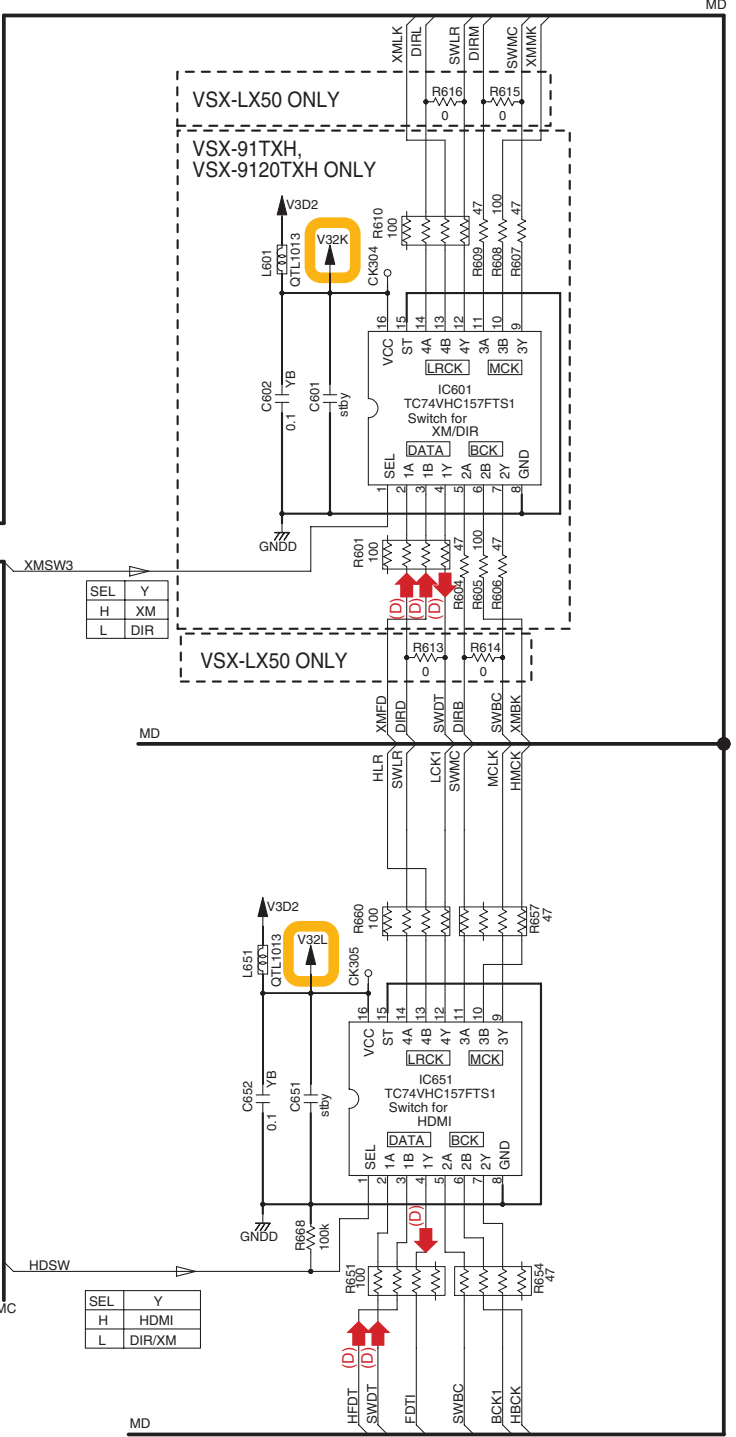

# 10.10 COMPOSITE ASSY

## COMPOSITE ASSY (VSX-LX50 : AWX8842) (VSX-91TXH, VSX-9120TXH : AWX8841)

IC1001 INPUT SELECTOR FOR VIDEO

51C	51B	51A	OUT
L	L	L	MUTE
L	L	H	DVR/VCR1
L	H	L	DVR/VCR2
L	H	H	DVD
H	L	L	TV
H	L	H	VIDEO
H	H	L	MUTE
H	H	H	iPod

AWX	JA1001	JA1002	JA1003	JA1004	JA1005	JA1006
8841	AKB7176	←	←	←	AKB7181	X
8842	AKB7176	←	←	X	X	AKB7175

IC1003 SELECTOR FOR DVCORTHRU

SWB	SWC	OUT
H	H	THRU
L	H	DVC
L	L	OSD

VIDEO

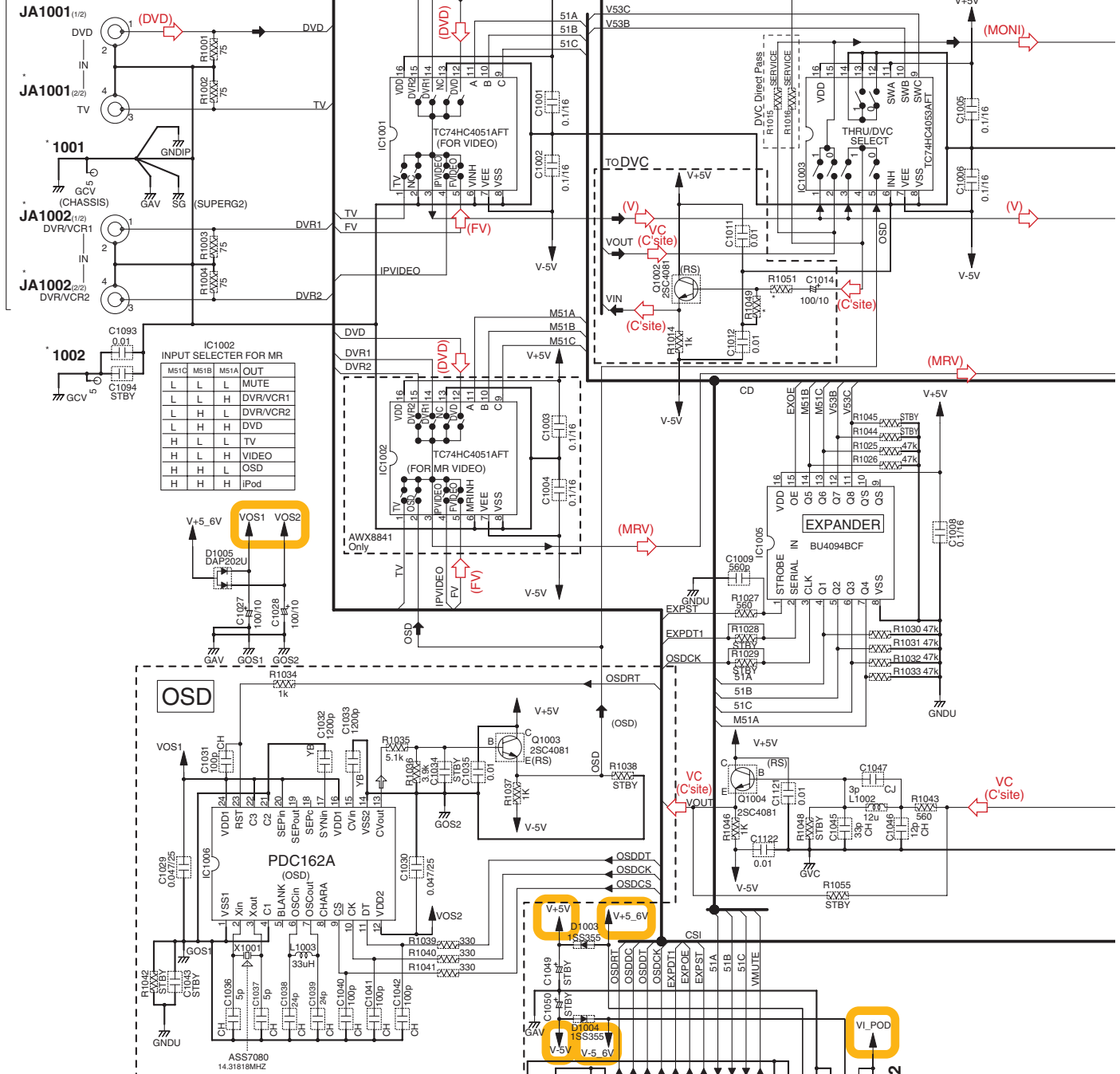

IC1002 INPUT SELECTOR FOR MR

M51C	M51B	M51A	OUT
L	L	L	MUTE
L	L	H	DVR/VCR1
L	H	L	DVR/VCR2
L	H	H	DVD
H	L	L	TV
H	L	H	VIDEO
H	H	L	OSD
H	H	H	iPod

OSD

PDC162A

ASS7080  
14.31818MHZ

- NOTES**
- RESISTORS  
Unit: k-k $\Omega$ , M-M $\Omega$  or  $\Omega$  unless otherwise noted.  
Rated power: 1/16W unless otherwise noted.  
Tolerance:  $\pm 5\%$ (J) unless otherwise noted.
  - CAPACITORS  
No marked Capacitors are CEAT or CKSRYB.  
Unit: p-pF or  $\mu$ F unless otherwise noted.  
Rated Voltage: shown as "Capacity( $\mu$ F)(Voltage(V))" or 50V unless otherwise noted.
  - DIODES  
No marked Diodes are 1SS355.  
\* Parts or parts block marked by "STBY" are standby.
- The  $\Delta$  mark found on some component parts indicates the importance of the safety factor of the part. Therefore, when replacing, be sure to use parts of identical designation.

AC CN3802

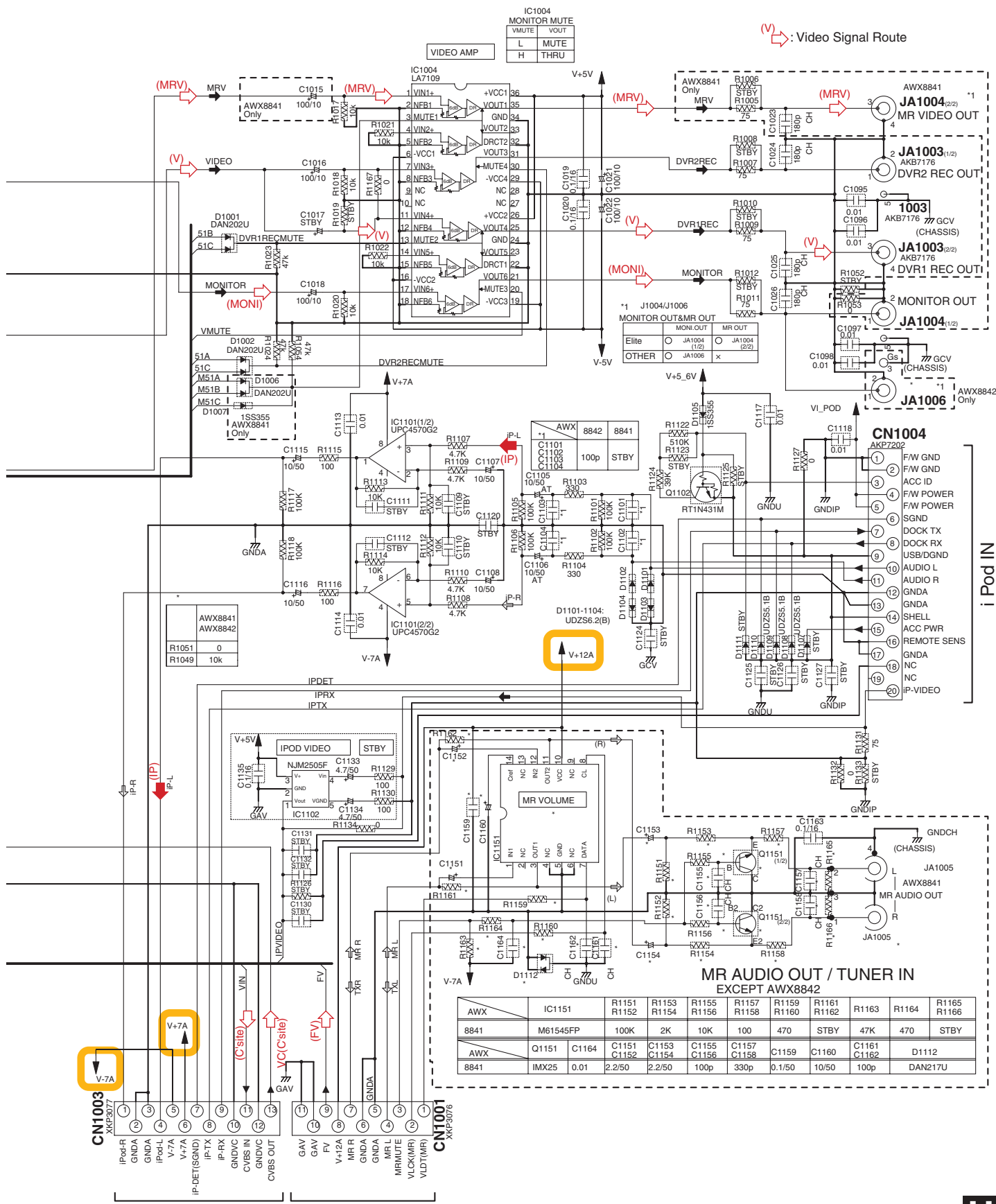

C 3/3 CN111

C 3/3 CN110

VSX-LX50



# 10.11 S-VIDEO and BRIDGE 2 ASSYS

## S-VIDEO ASSY (VSX-LX50 : AWX8845) (VSX-91TXH, VSX-9120TXH : AWX8844)

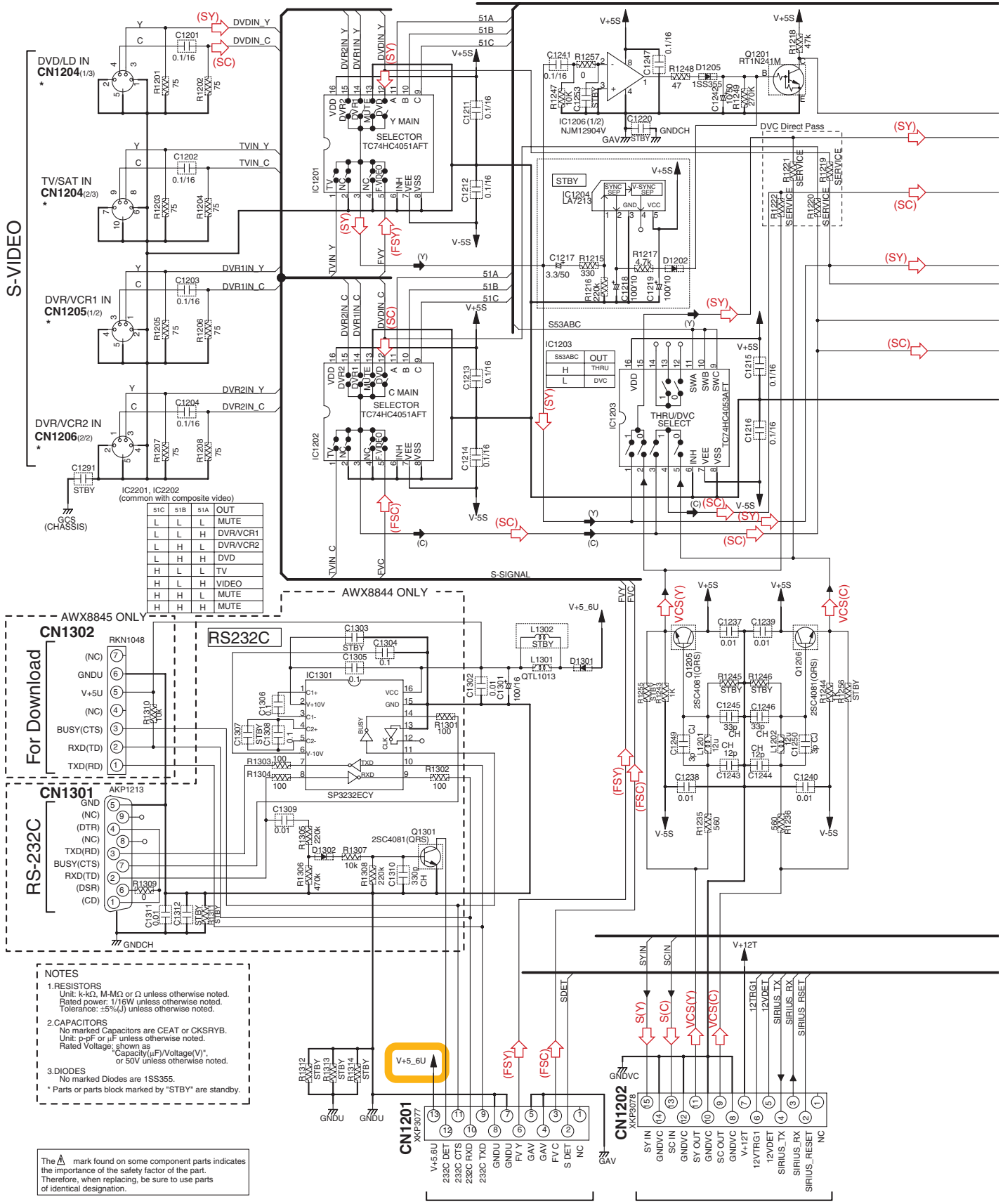

C 3/3 CN108

C 3/3 CN109

VSX-LX50



# 10.12 COMPONENT ASSY

A  
B  
C  
D  
E  
F

**NOTES**

1. RESISTORS  
Unit: k-k $\Omega$ , M-M $\Omega$  or  $\Omega$  unless otherwise noted.  
Rated power: 1/16W unless otherwise noted.  
Tolerance:  $\pm 5\%$  ( $\Omega$ ) unless otherwise noted.

2. DIODES  
No marked Diodes are 1SS355.  
\* Parts or parts block marked by "STBY" are standby.

3. CAPACITORS  
No marked Capacitors are CEAT or CKSRYB  
Unit: p-pF or  $\mu$ F unless otherwise noted.  
Rated Voltage: shown as "Capacity( $\mu$ F)/Voltage(V)" or 50V unless otherwise noted.

IC2401 & IC2402				IC2404	
CSW1	CSW1	Selector		C53B	Selector
L	L	D		L	DVC
H	L	Comp In 1		H	THRU
L	H	Comp In 2			
H	H	Comp In 3			

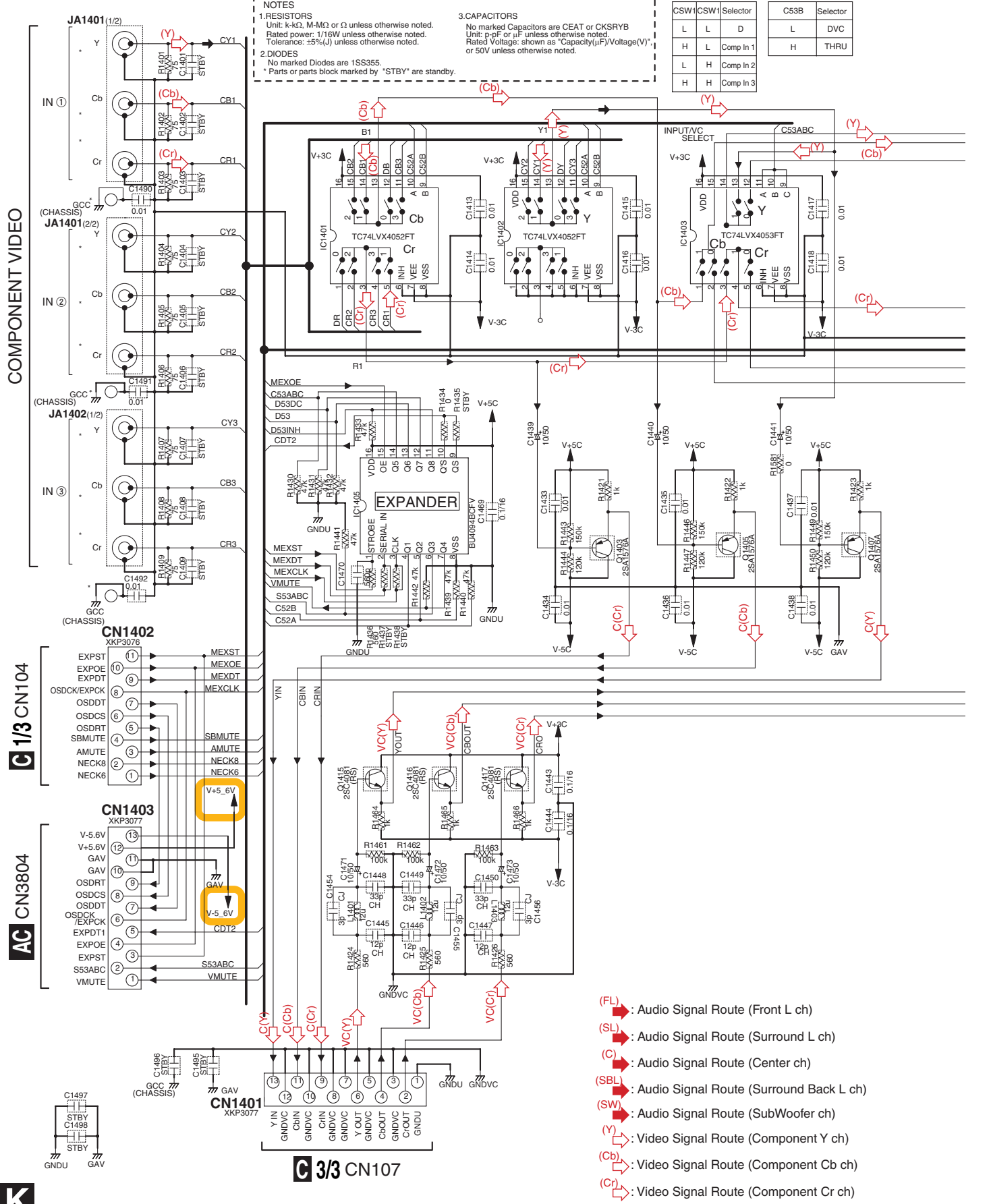

- (FL) : Audio Signal Route (Front L ch)
- (SL) : Audio Signal Route (Surround L ch)
- (C) : Audio Signal Route (Center ch)
- (SBL) : Audio Signal Route (Surround Back L ch)
- (SW) : Audio Signal Route (SubWoofer ch)
- (Y) : Video Signal Route (Component Y ch)
- (Cb) : Video Signal Route (Component Cb ch)
- (Cr) : Video Signal Route (Component Cr ch)

**C 3/3 CN107**

**VSX-LX50**

IC2405	VMUTE	MONI.OUT
	L	MUTE
	H	THRU

1401



VEF1040

# K COMPONENT ASSY

(VSX-LX50 : AWX8848)  
(VSX-91TXH, VSX-9120TXH : AWX8847)

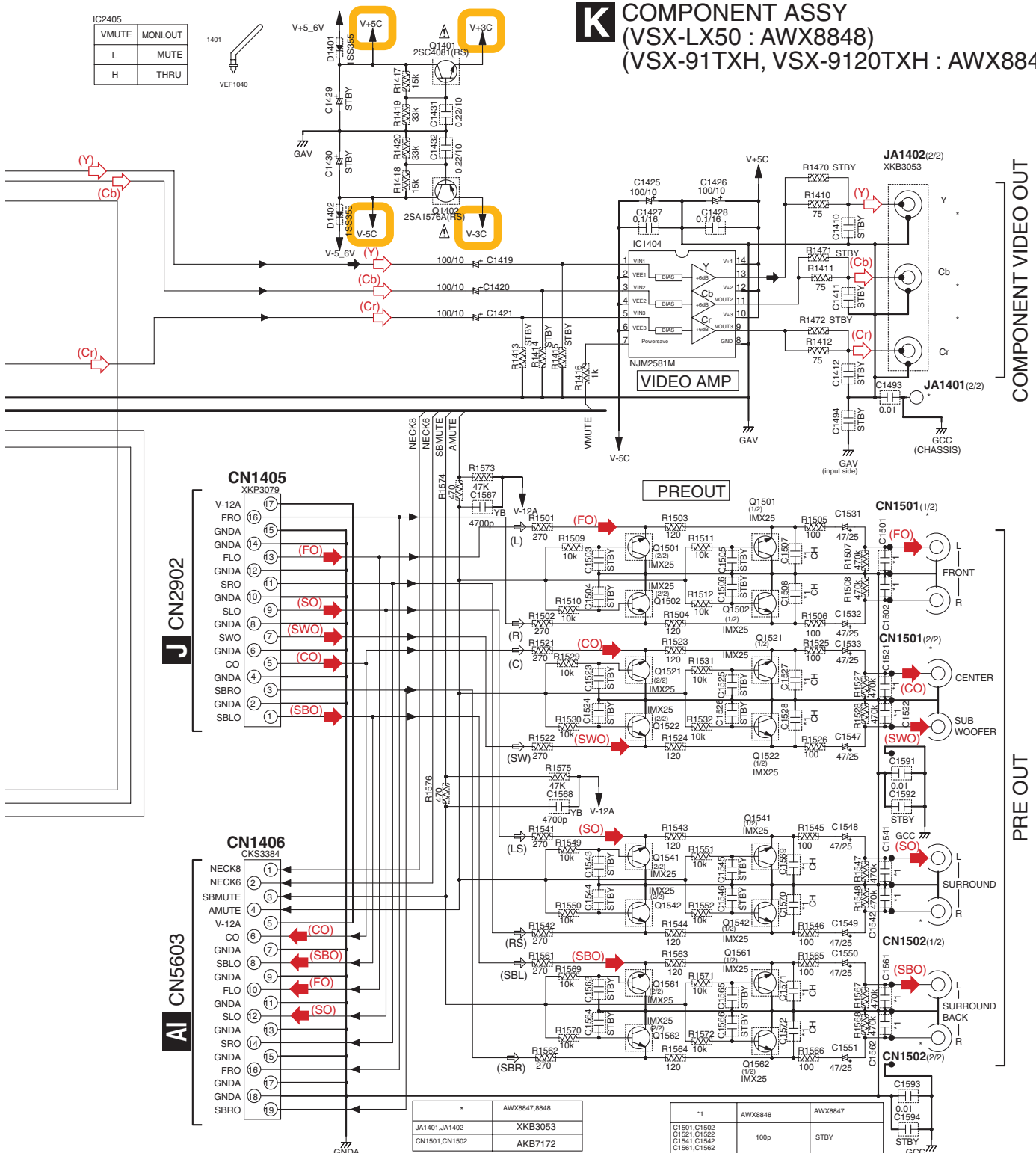

COMPONENT VIDEO OUT

PRE OUT

J CN2902

A1 CN5603

*	AWX8847,8848
JA1401,JA1402	XKB3053
CN1501,CN1502	AKB7172

*1	AWX8848	AWX8847
C1501,C1502	100p	STBY
C1521,C1522	100p	STBY
C1541,C1542	100p	STBY
C1561,C1562	100p	STBY
C1507,C1508	270p	STBY
C1527,C1528	270p	STBY
C1569,C1570	270p	STBY
C1571,C1572	270p	STBY

The mark found on some component parts indicates the importance of the safety factor of the part. Therefore, when replacing, be sure to use parts of identical designation.



# 10.13 DISPLAY, VOLUME and MULTI JOG ASSYS

**DISPLAY ASSY**  
 (VSX-LX50 : AWX8874)  
 (VSX-91TXH, VSX-9120TXH : AWX8873)

A  
B  
C  
D  
E  
F

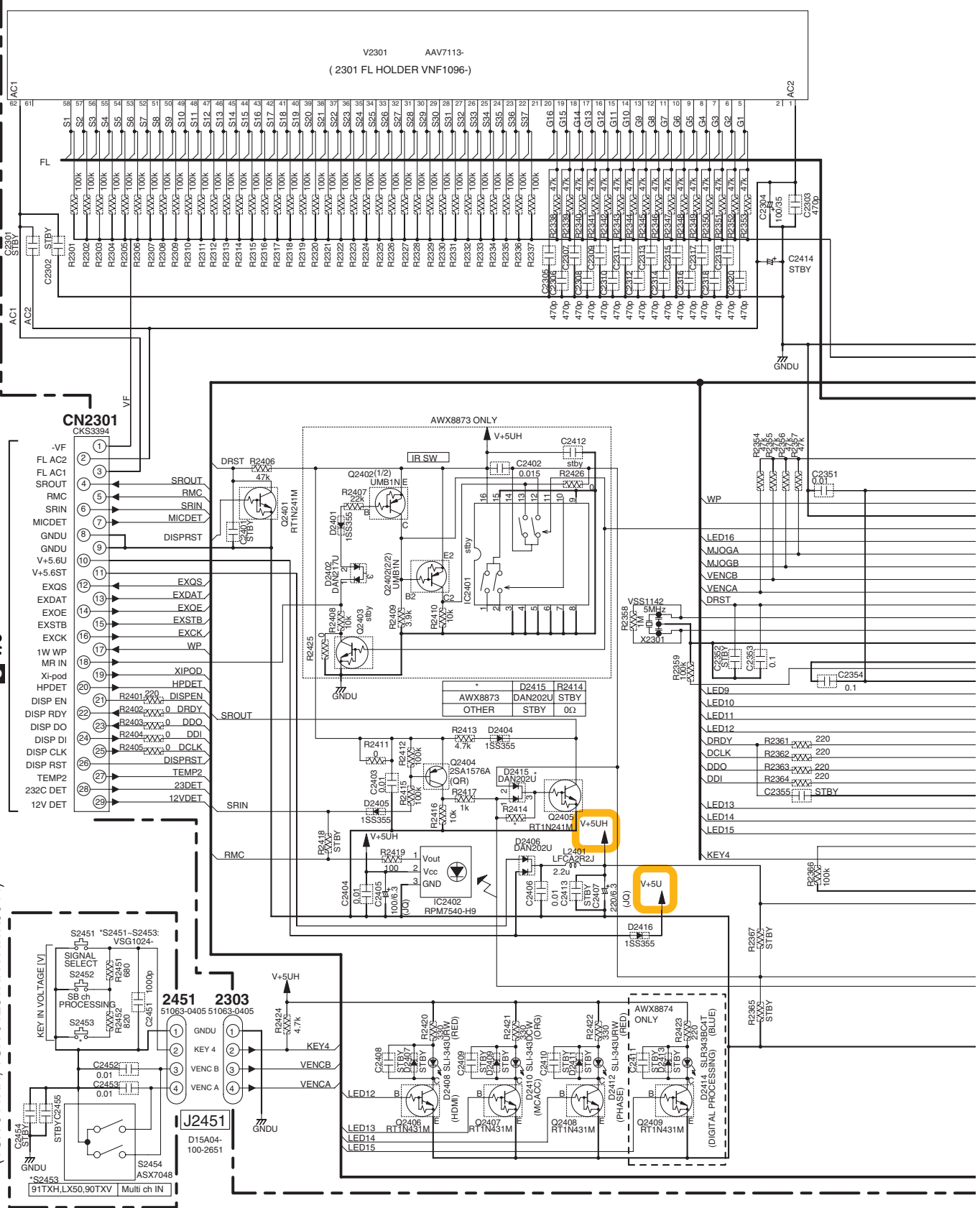

**VOLUME ASSY**  
 (VSX-LX50 : AWX9111)  
 (VSX-91TXH, VSX-9120TXH : AWX9044)



**N** MULTI JOG ASSY  
 (VSX-LX50 : AWX8880)  
 (VSX-91TXH, VSX-9120TXH : AWX8879)

KEY NAME	S2551	S2552	S2553	S2554	S2555	S2556	S2557	S2558	S2559	S2560	S2561	S2562	S2563	S2564	S2565	S2566	S2567	S2568	S2569	S2570	S2571	S2572	S2573	S2574	S2575	S2576	S2577	
VSX-91TXH	DVR/VCR1	VIDEO GAME	CD	CD-R TAPE MD	FM AM	XM	SIRIUS	IPOD	HDMI Multi 2 IN	TUNING STATION	TUNER EDIT	Phase Control	Multi ZONE Control	Acoustic EQ			DVR/VCR1	DVR/VCR2										
VSX-LX50	DVR/VCR2	VIDEO GAME	CD	CD-R TAPE MD	FM AM	XM	SIRIUS	IPOD	HDMI Multi 2 IN	1	1	EON MODE					DVR/VCR1	DVR/VCR2										

**NOTE**

1. RESISTORS  
 Unit: k $\Omega$ , M $\Omega$  or  $\Omega$  unless otherwise noted.  
 Rated power: 1/10W unless otherwise noted.  
 Tolerance: (J)  $\pm 5\%$  unless otherwise noted.

2. CAPACITORS  
 Unit: pF or  $\mu$ F unless otherwise noted.  
 Ratings: Capacity ( $\mu$ F)/Voltage (V) unless otherwise noted.  
 Rated Voltage: 50V except for electrolytic capacitors.

3. DIODES  
 Indicated in 1SS355.

4. TACT SWITCHES  
 Indicated in VSG1024.

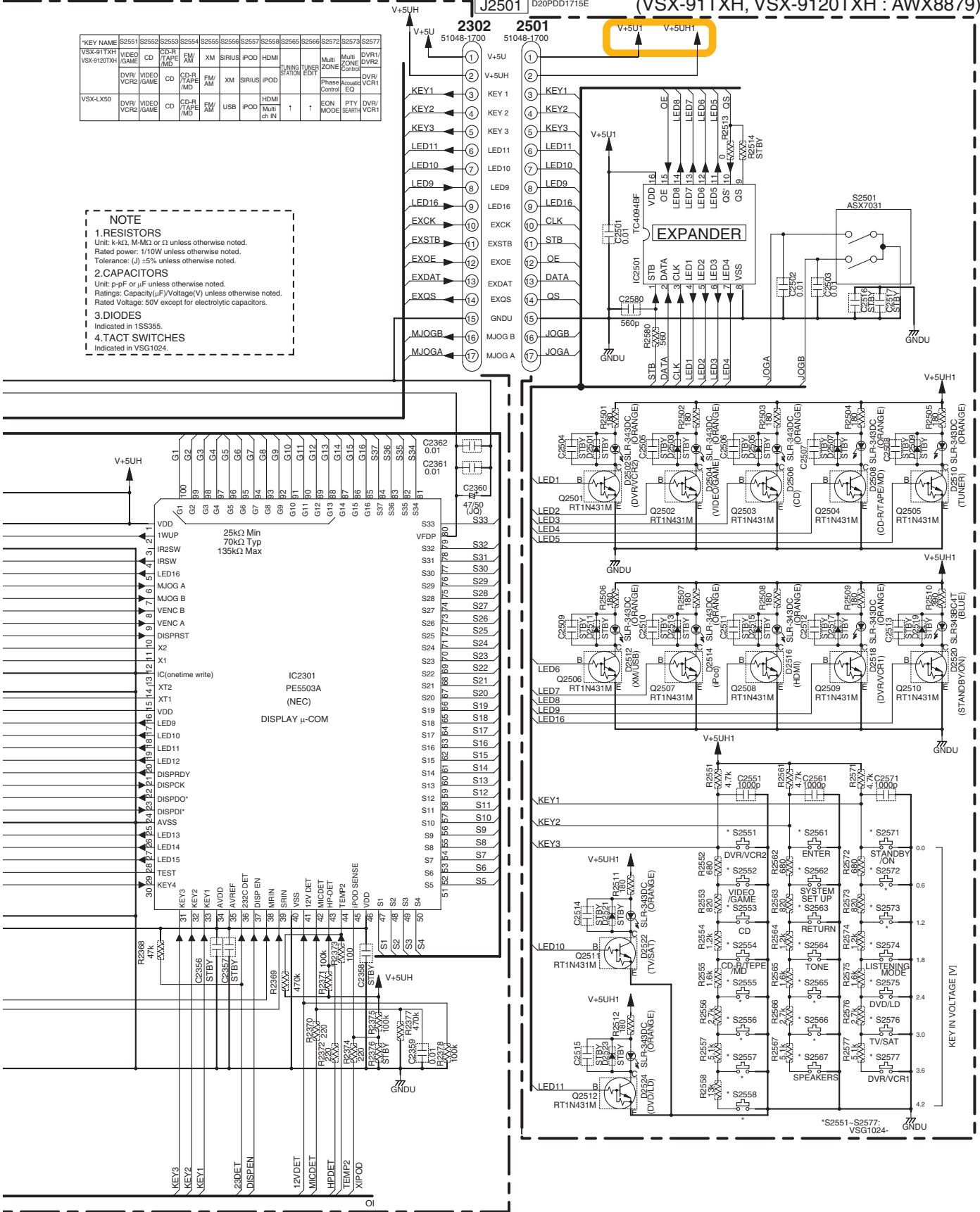

A  
B  
C  
D  
E  
F

# 10.14 HEADPHONE, FRONT-IN, PRIMARY and TRANS 1 ASSYS

## O HEADPHONE ASSY (AWX9049)

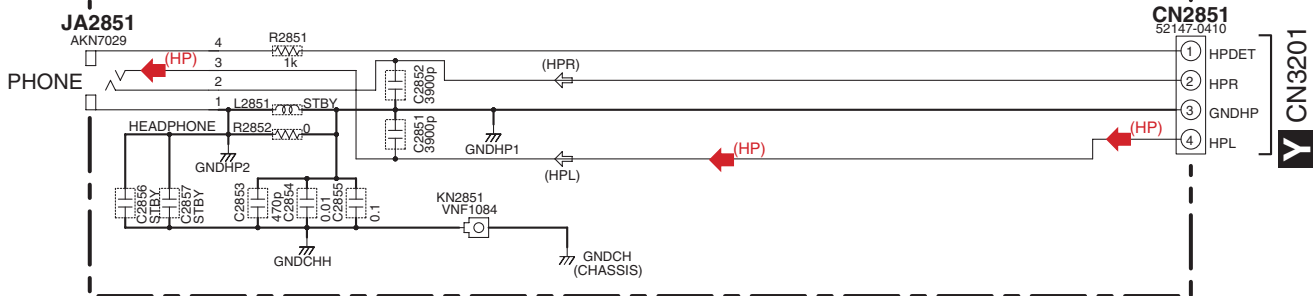

## P FRONT-IN ASSY (VSX-LX50 : AWX8955) (VSX-91TXH, VSX-9120TXH : AWX8954)

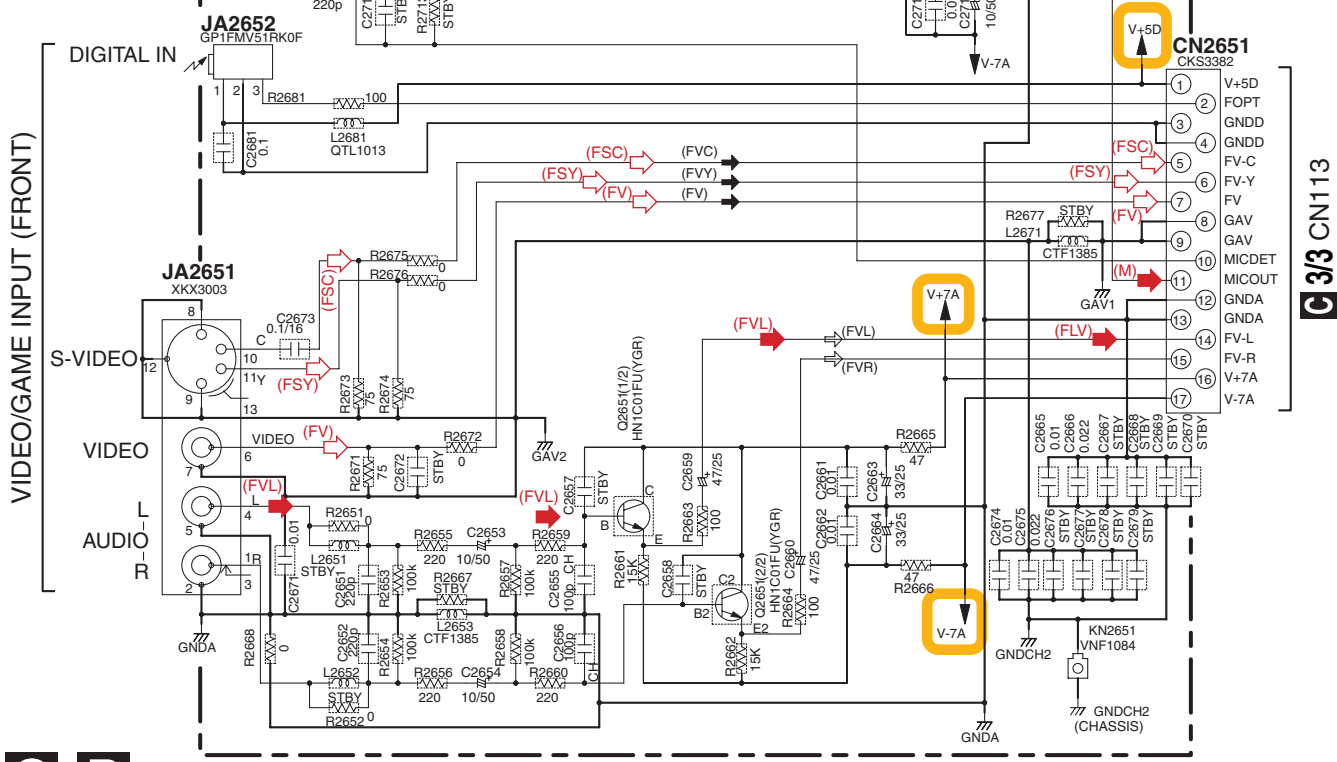
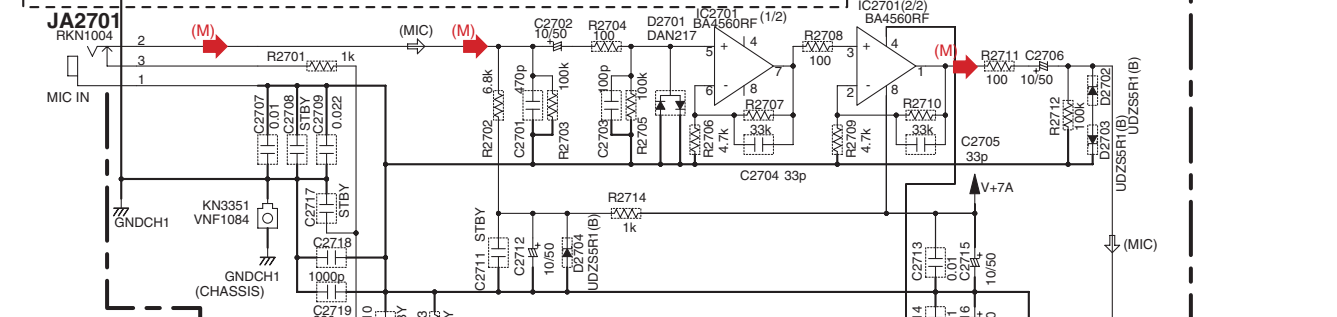
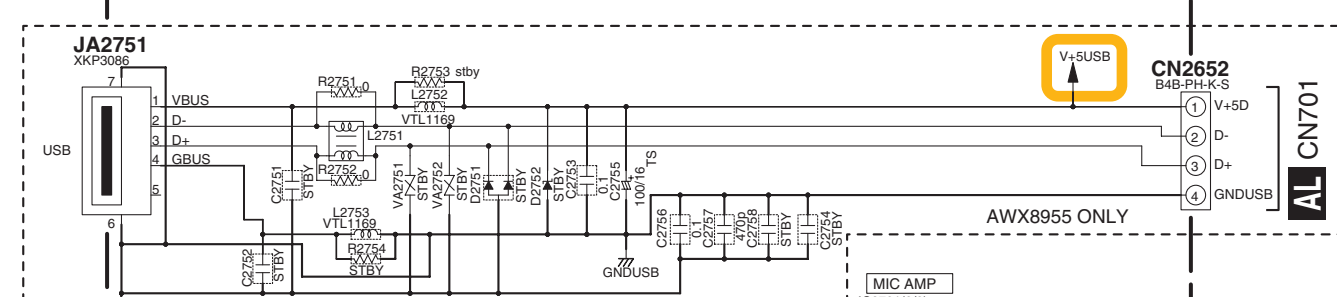

## O P

**Q** PRIMARY ASSY (VSX-LX50 : AWX9035)  
(VSX-91TXH, VSX-9120TXH : AWX9034)

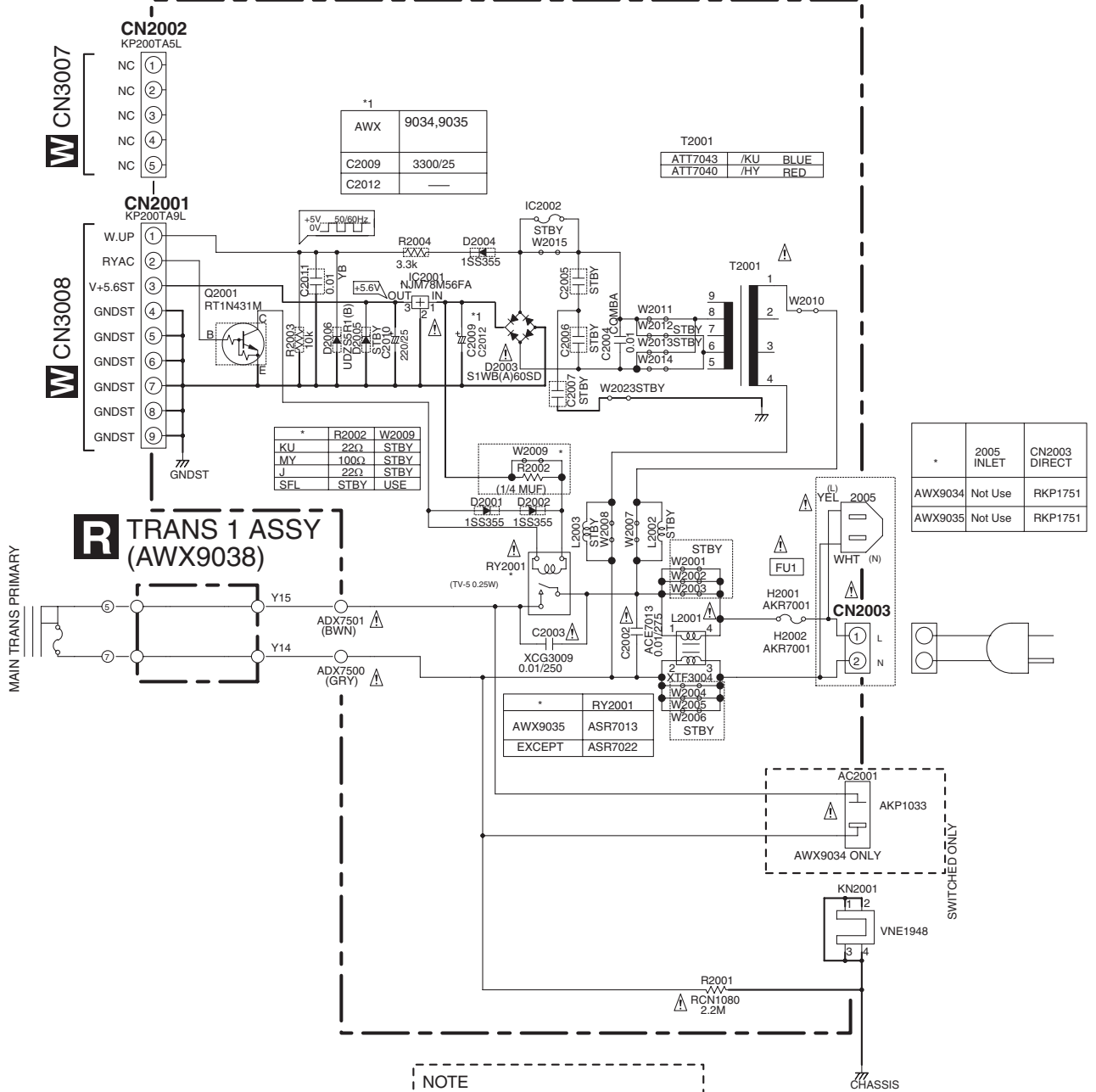

AWX	9034,9035
C2009	3300/25
C2012	—

T2001		
ATT7043	/KU	BLUE
ATT7040	/HY	RED

*	R2002	W2009
KU	22Ω	STBY
MY	100Ω	STBY
J	22Ω	STBY
SFL	STBY	USE

*	2005 INLET	CN2003 DIRECT
AWX9034	Not Use	RKP1751
AWX9035	Not Use	RKP1751

*	RY2001
AWX9035	ASR7013
EXCEPT	ASR7022

**NOTE**

1. RESISTORS  
Unit: k-Ω, M-Ω or Ω unless otherwise noted.  
Rated power: 1/10W unless otherwise noted.  
Tolerance: (J) ±5% unless otherwise noted.

2. CAPACITORS  
Unit: p-pF or μF unless otherwise noted.  
Ratings: Capacity(μF)/Voltage(V) unless otherwise noted.  
Rated Voltage: 50V except for electrolytic capacitors.

3. DIODES  
Indicated in 1SS355.

**NOTE FOR FUSE REPLACEMENT**

**CAUTION** - FOR CONTINUED PROTECTION AGAINST RISK OF FIRE, REPLACE WITH SAME TYPE AND RATINGS OF FUSE.

The **A** mark found on some component parts indicates the importance of the safety factor of the part. Therefore, when replacing, be sure to use parts of identical designation.

- (L) : Audio Signal Route (L ch)
- (M) : Audio Signal Route (Mic ch)
- (V) : Video Signal Route
- (SY) : S-Video Signal Route (Y ch)
- (SC) : S-Video Signal Route (C ch)

# 10.15 TRANS 2-1, DIODE 1, VH TR, BRIDGE 1 and PS/SP ASSYS

A

B

C

D

E

F

## S TRANS 2-1 ASSY (VSX-LX50 : AWX9059) (VSX-91TXH, VSX-9120TXH : AWX9058)

CAUTION : FOR CONTINUED PROTECTION AGAINST RISK OF FIRE. REPLACE ONLY WITH SAME TYPE NO. 491007 MFD, BY LITTELFUSE INC. FOR IC3251 and IC3252.

## T DIODE 1 ASSY (AWX9060)

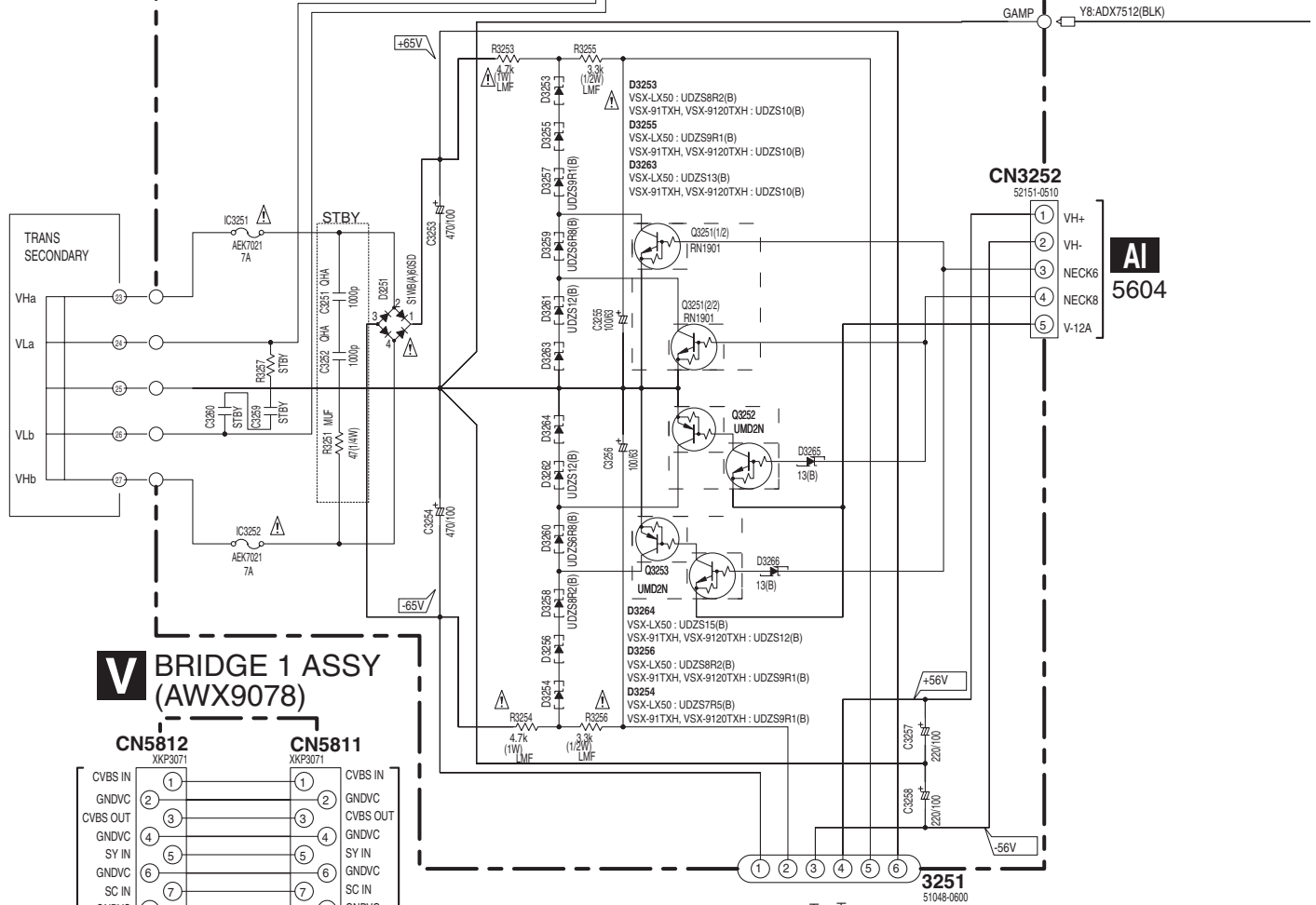

## V BRIDGE 1 ASSY (AWX9078)

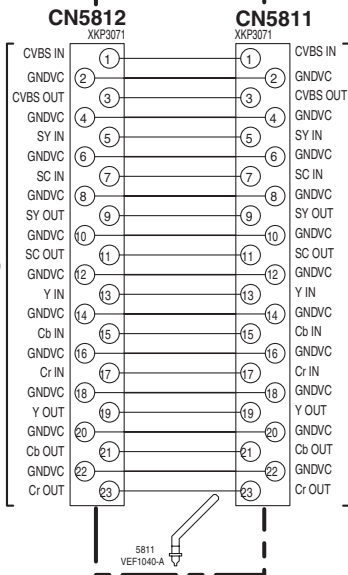

C 3/3  
CN106

AK 2/2  
CN1002

## U

## VH TR ASSY (AWX9061)

CAUTION : FOR CONTINUED PROTECTION AGAINST RISK OF FIRE. REPLACE ONLY WITH SAME TYPE NO. ICP-N15, MFD BY ROHM CO., LTD. FOR IC3351 and IC3352.

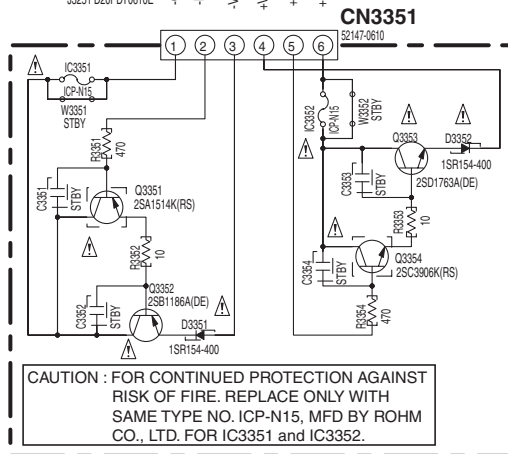

S T U V

**W** PS/SP ASSY  
 (VSX-LX50 : AWX9107)  
 (VSX-91TXH, VSX-9120TXH : AWX9052)

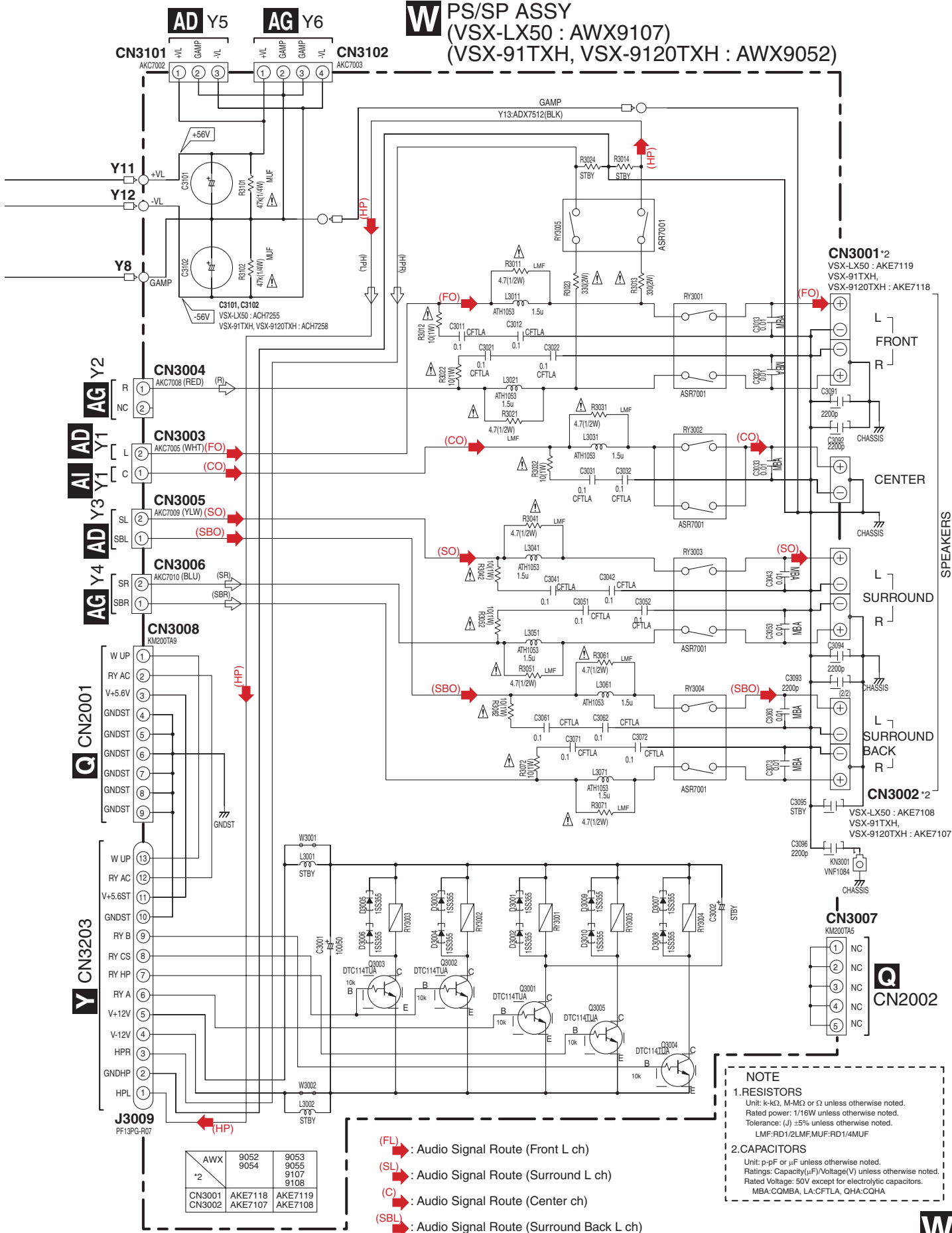

AWX	9052	9053
*2	9054	9055
CN3001	AKE7118	AKE7119
CN3002	AKE7107	AKE7108

- (FL) → Audio Signal Route (Front L ch)
- (SL) → Audio Signal Route (Surround L ch)
- (C) → Audio Signal Route (Center ch)
- (SBL) → Audio Signal Route (Surround Back L ch)

**NOTE**

**1. RESISTORS**  
 Unit: k-k $\Omega$ , M-M $\Omega$  or  $\Omega$  unless otherwise noted.  
 Rated power: 1/16W unless otherwise noted.  
 Tolerance: ( $\pm$ )  $\pm$ 5% unless otherwise noted.  
 LMF: RD1/2LMF, MUF: RD1/4MUF

**2. CAPACITORS**  
 Unit: p-pF or  $\mu$ F unless otherwise noted.  
 Ratings: Capacity( $\mu$ F)/Voltage(V) unless otherwise noted.  
 Rated Voltage: 50V except for electrolytic capacitors.  
 MBA: COMBA, LA: CFTLA, QHA: COHA

# 10.16 TRANS 2-2, TRANS SIDE, LOCAL P-SUPPLY, DC/DC, IR I/O and VIDEO CONNECT ASSYS

## Z LOCAL P-SUPPLY ASSY (VSX-LX50 : AWX9064) (VSX-91TXH, VSX-9120TXH : AWX9063)

NOTE FOR FUSE REPLACEMENT

**CAUTION** - FOR CONTINUED PROTECTION AGAINST RISK OF FIRE. REPLACE WITH SAME TYPE AND RATINGS OF FUSE.

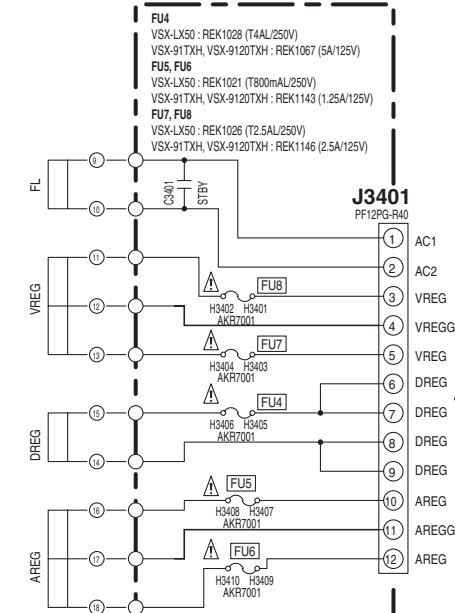

### X TRANS 2-2 ASSY (AWX9062)

**NOTE 1. RESISTORS**  
Unit: MΩ, M, KΩ or Ω unless otherwise noted.  
Rated power: 1/8W unless otherwise noted.  
Tolerance: (Ω) ±5% unless otherwise noted.

**2. CAPACITORS**  
Unit: μF or pF unless otherwise noted.  
Rating: Capacitance (V) unless otherwise noted.  
Rated Voltage: 50V except for electrolytic capacitors.

### Y TRANS SIDE ASSY (AWX9056)

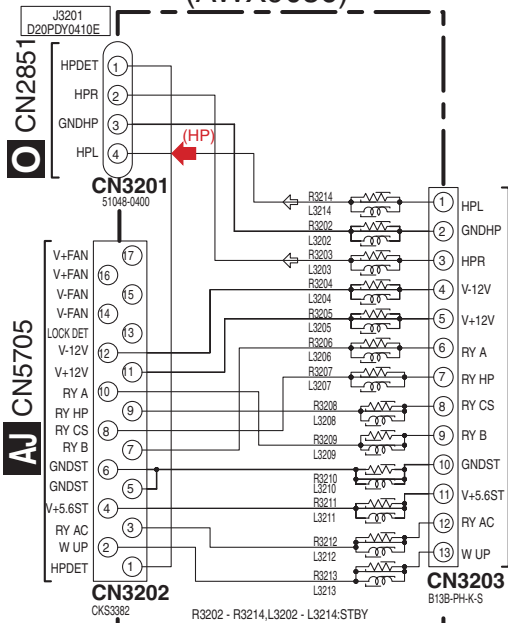

### X Y Z AA

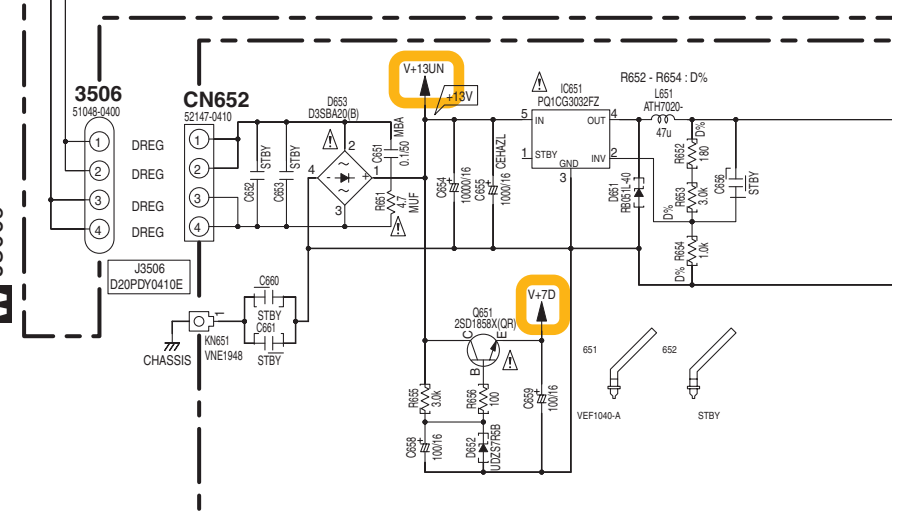
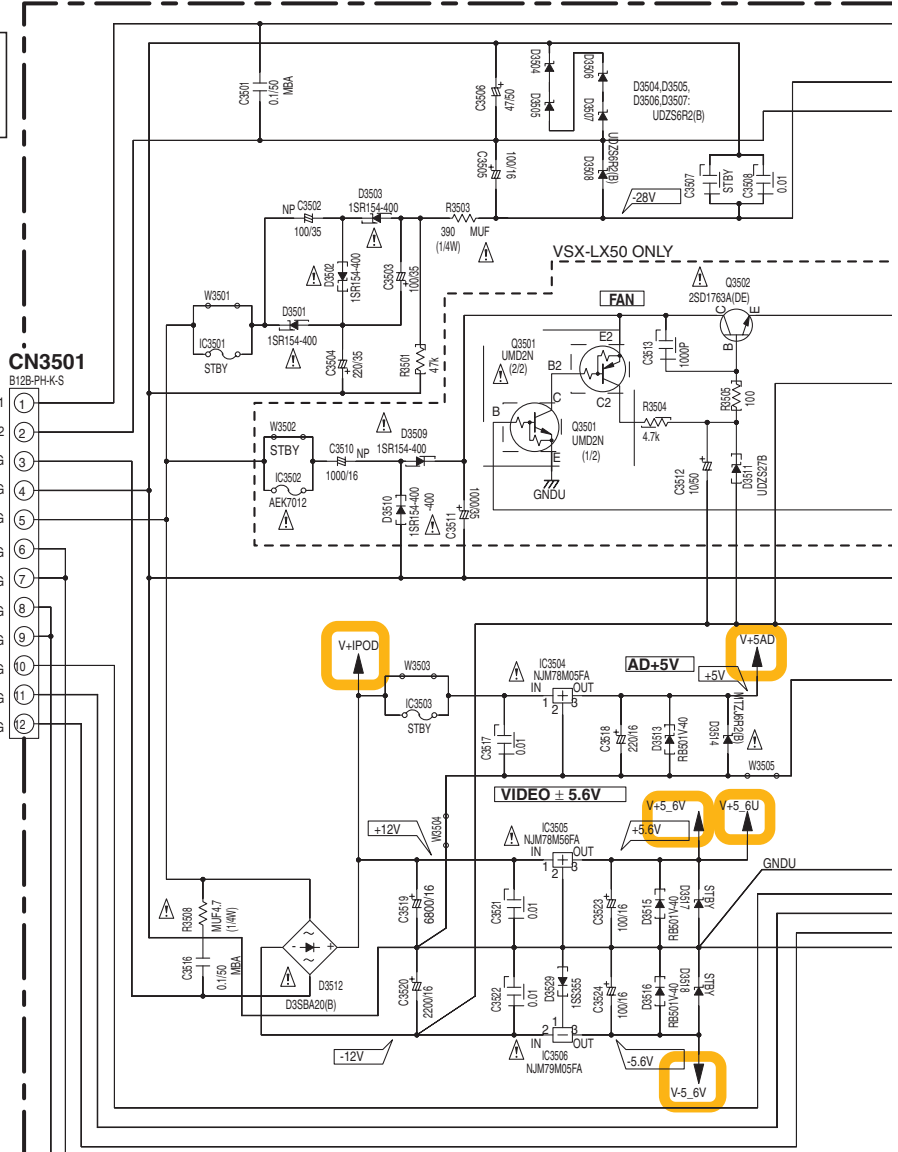

### AA DC/DC ASSY (AWX9015)

(L) : Audio Signal Route (L ch)  
 (D) : Audio Data Route

**AB** IR I/O ASSY  
 (VSX-LX50 : AWX9067)  
 (VSX-91TXH, VSX-9120TXH : AWX9066)

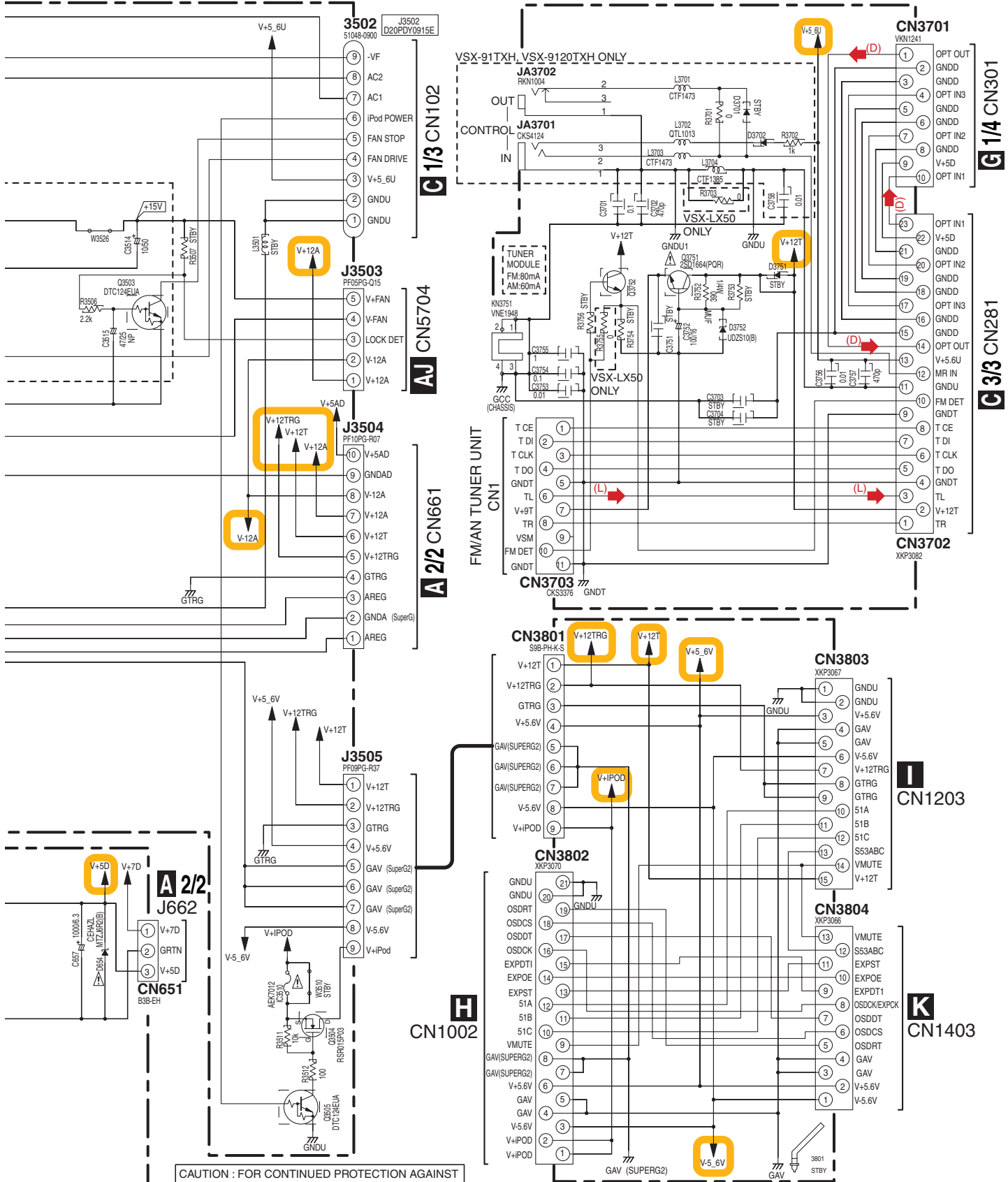

CAUTION : FOR CONTINUED PROTECTION AGAINST RISK OF FIRE. REPLACE ONLY WITH SAME TYPE NO. 49101.6 MFD, BY LITTELFUSE INK. FOR IC3510.

**AC** VIDEO CONNECT ASSY (AWX9069)

**Z AB AC**

# 10.17 POWER AMP-L, POSI 1-L and POSI 2-L ASSYS

## AD POWER AMP-L ASSY (VSX-LX50 : AWX9072) (VSX-91TXH, VSX-9120TXH : AWX9071)

A

B

C

D

E

F

**AE**  
POSI 1-L ASSY  
(VSX-LX50 : AWX9081)  
(VSX-91TXH, VSX-9120TXH : AWX9080)

**AF**  
POSI 2-L ASSY  
(AWX9082)

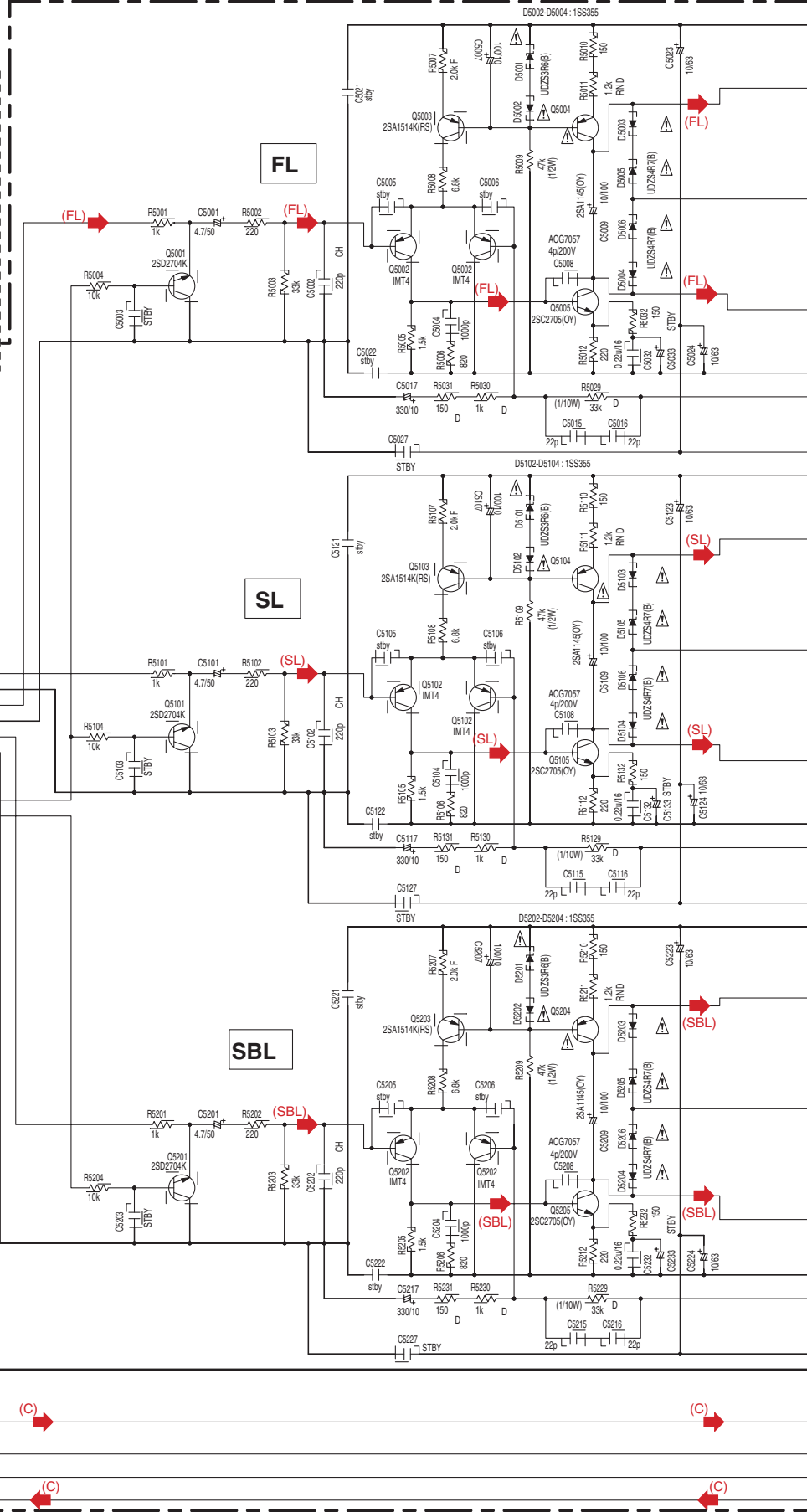
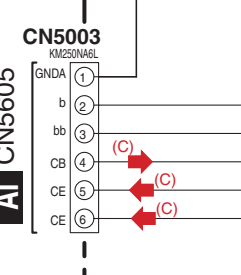
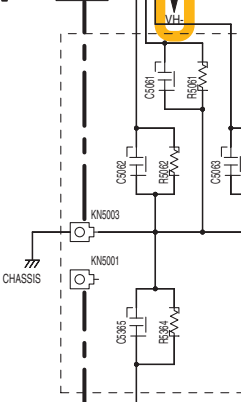
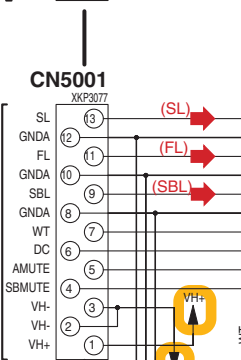
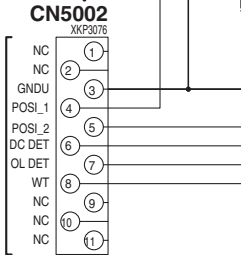
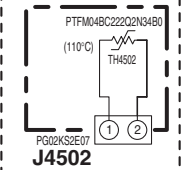
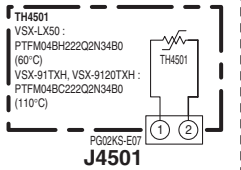

VSX-LX50

A

B

C

D

E

F

1

2

3

4

- (FL) : Audio Signal Route (Front L ch)
- (SL) : Audio Signal Route (Surround L ch)
- (C) : Audio Signal Route (Center ch)
- (SBL) : Audio Signal Route (Surround Back L ch)

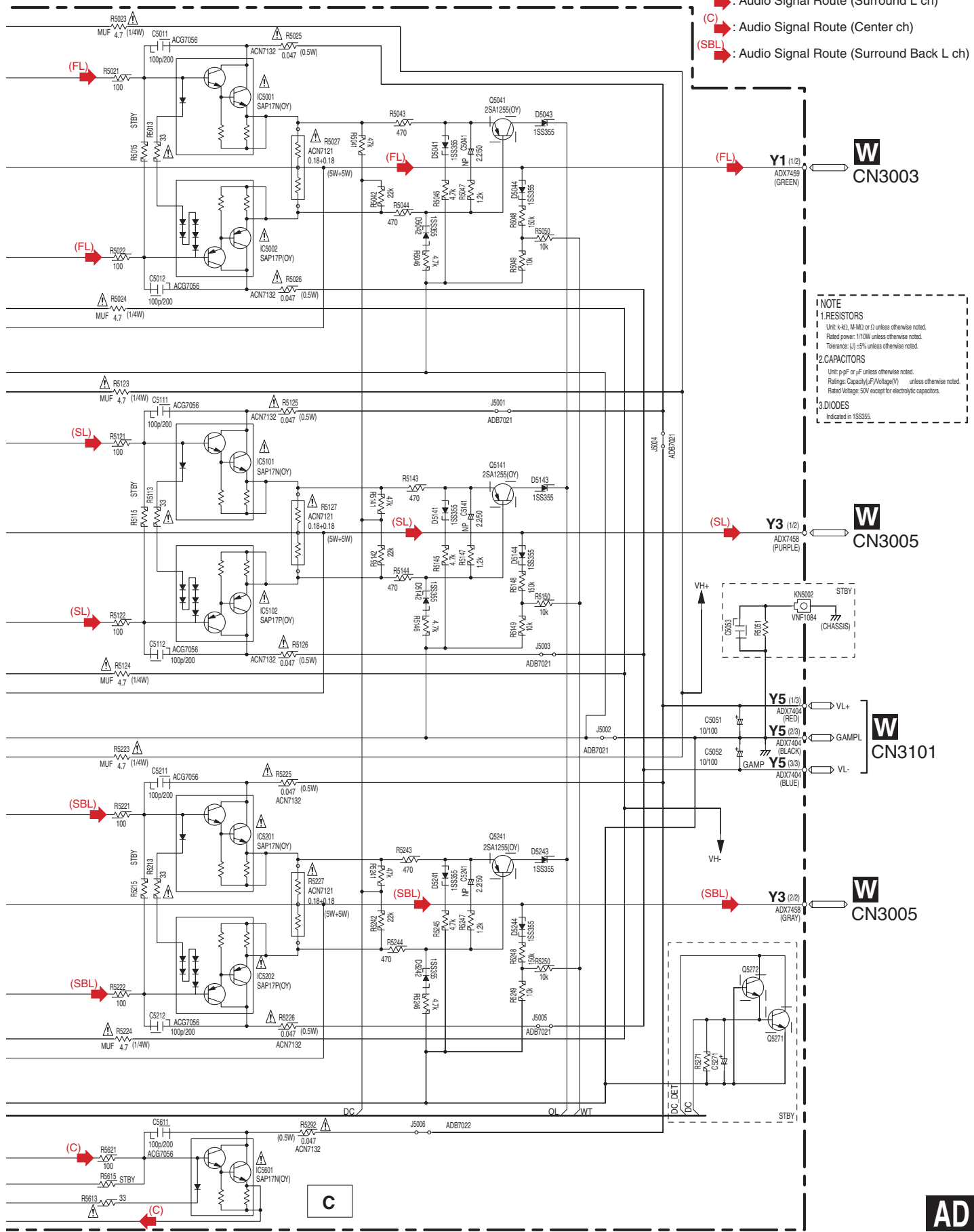

**NOTE**

**1.RESISTORS**  
 Unit: k- $\Omega$ , M-M $\Omega$  or  $\Omega$  unless otherwise noted.  
 Rated power: 1/10W unless otherwise noted.  
 Tolerance: (J)  $\pm$ 5% unless otherwise noted.

**2.CAPACITORS**  
 Unit: p-pF or  $\mu$ F unless otherwise noted.  
 Ratings: Capacity( $\mu$ F)/Voltage(V) unless otherwise noted.  
 Rated Voltage: 50V except for electrolytic capacitors.

**3.DIODES**  
 Indicated in 1SS335.

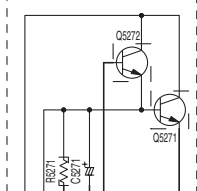
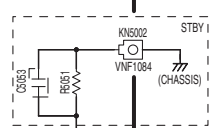

# 10.18 POWER AMP-R and POSI 1-R ASSYS

## AG POWER AMP-R ASSY (VSX-LX50 : AWX9073) (VSX-91TXH, VSX-9120TXH : AWX9106)

### AH

POSI 1-R ASSY  
(VSX-LX50 : AWX9084)  
(VSX-91TXH, VSX-9120TXH : AWX9083)

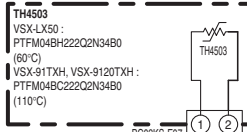

J4551

CN5304

B2B-PHK-S

CN5302

XKP3076

AJ CN5702



CN5301

XKP3077

AI CN5602



VH+

VH-

CN5303

KMZ50NABL

AI CN5606

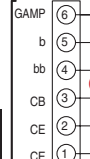

FR

SR

SBR

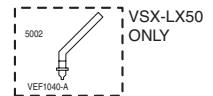

VSX-LX50 ONLY

C

(C) : Audio Signal Route (Center ch)

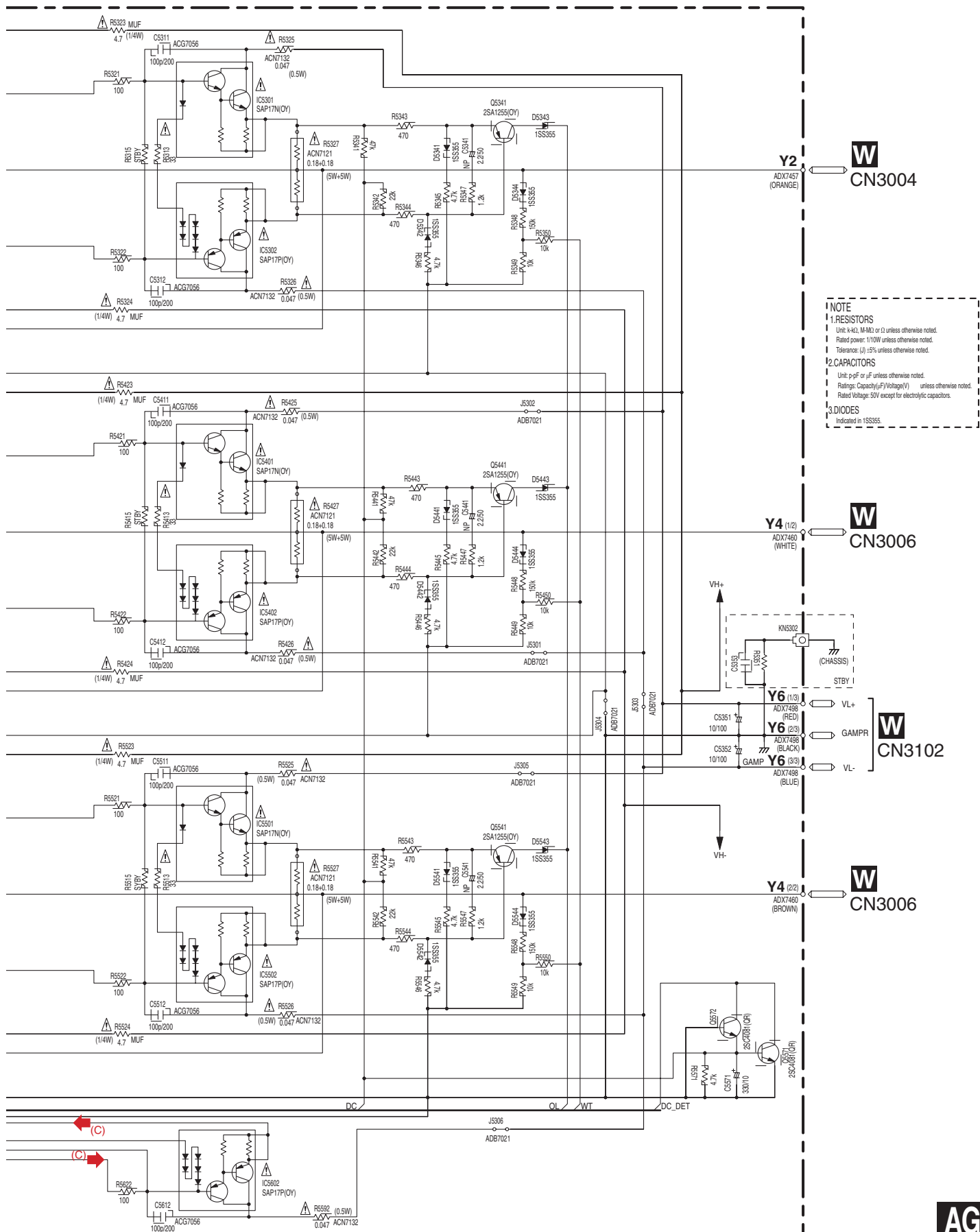

**NOTE**

**1. RESISTORS**  
 Unit: k-k $\Omega$ , M-M $\Omega$  or  $\Omega$  unless otherwise noted.  
 Rated power: 1/10W unless otherwise noted.  
 Tolerance: (J)  $\pm$ 5% unless otherwise noted.

**2. CAPACITORS**  
 Unit: p-pF or  $\mu$ F unless otherwise noted.  
 Ratings: Capacitance (pF/Voltage(V)) unless otherwise noted.  
 Rated Voltage: 50V except for electrolytic capacitors.

**3. DIODES**  
 Indicated in 1SS355.

VSX-LX50



# 10.19 POWER AMP IN and POWER PROTECT ASSYS

1

2

3

4

A

B

C

D

E

F

**AG** CN5301

**AI**

POWER AMP IN ASSY (AWX9075)

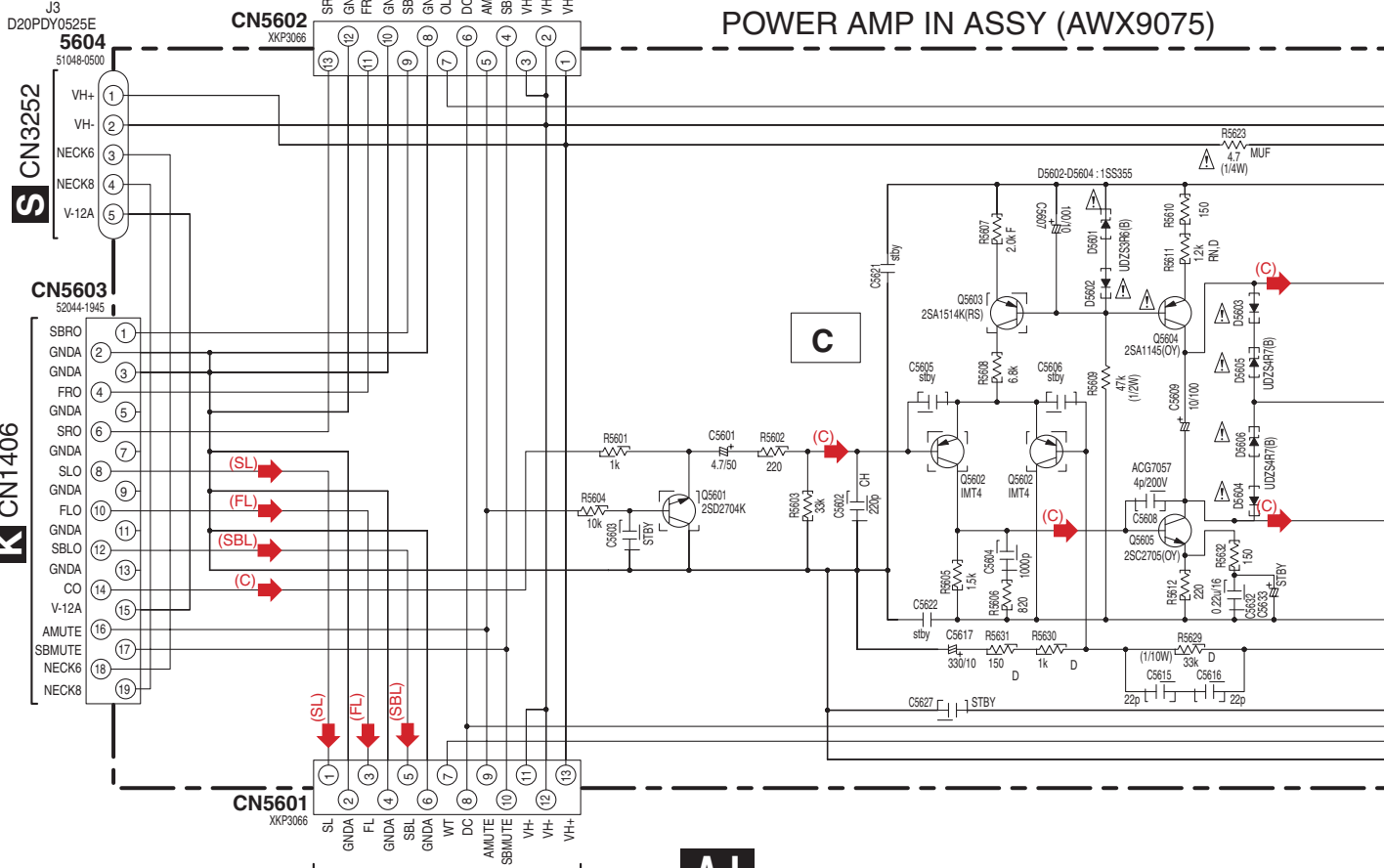

**AJ**

POWER PROTECT ASSY  
(VSX-LX50 : AWX9077)  
(VSX-91TXH, VSX-9120TXH : AWX9076)

**C** 1/3 CN103

**AD** CN5001

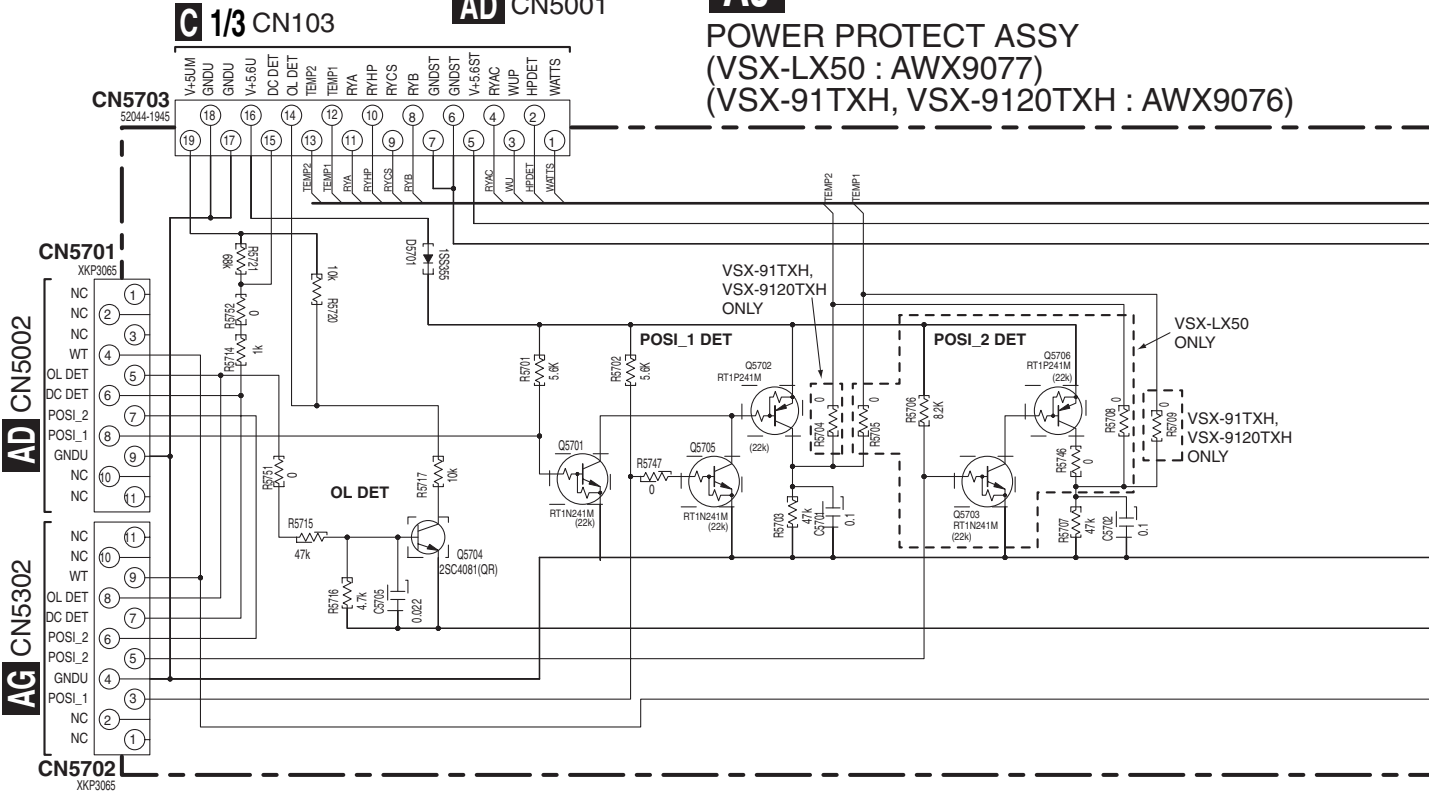

**AI** **AJ**

VSX-LX50

1

2

3

4

- (FL) : Audio Signal Route (Front L ch)
- (SL) : Audio Signal Route (Surround L ch)
- (C) : Audio Signal Route (Center ch)
- (SBL) : Audio Signal Route (Surround Back L ch)

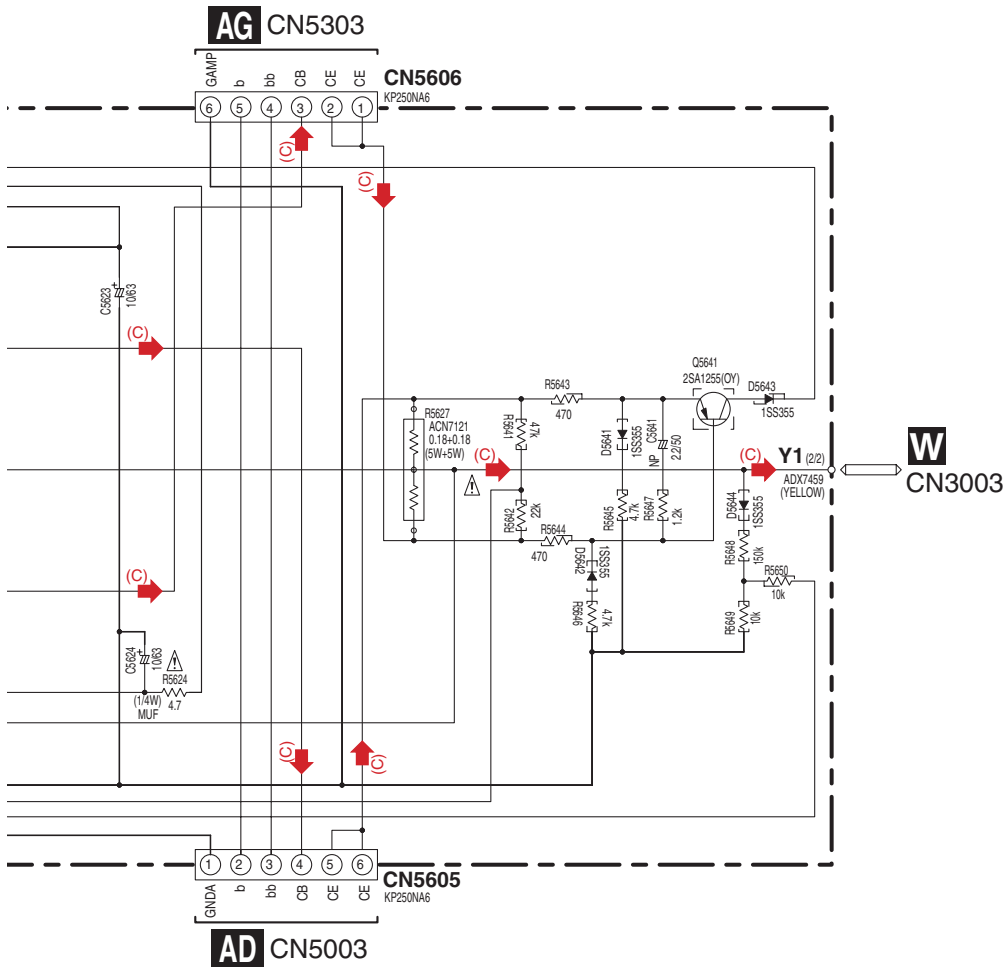

**NOTE**

**1.RESISTORS**  
 Unit: k-kΩ, M-MΩ or Ω unless otherwise noted.  
 Rated power: 1/16W unless otherwise noted.  
 Tolerance: (J) ±5% unless otherwise noted.

**2.CAPACITORS**  
 Unit: p-pF or μF unless otherwise noted.  
 Ratings: Capacity(μF)/Voltage(V) unless otherwise noted.  
 Rated Voltage: 50V except for electrolytic capacitors.

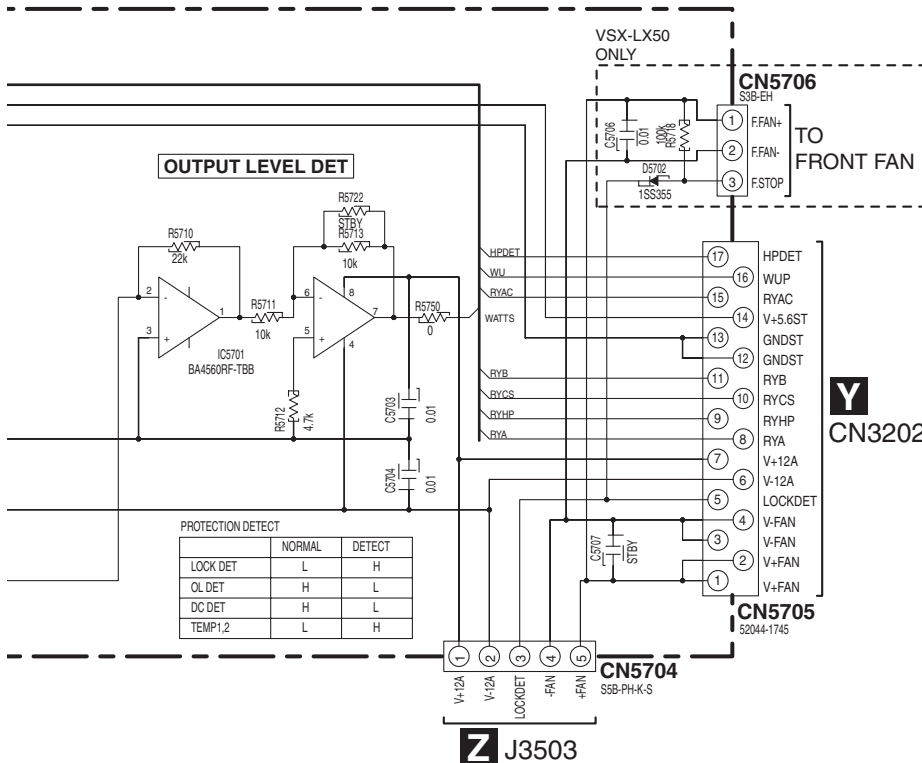

# 10.20 HDMI & DVC ASSY (1/2)

## AK 1/2 HDMI & DVC ASSY (AWQ7040)

A

B

C

D

E

F

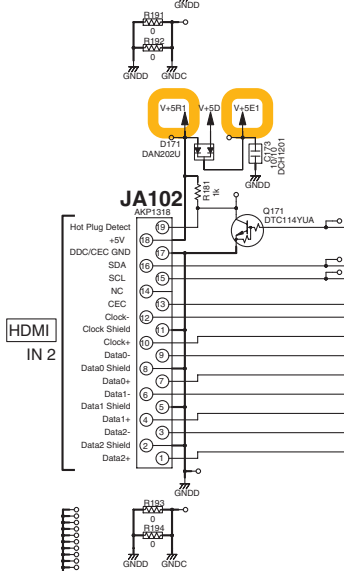
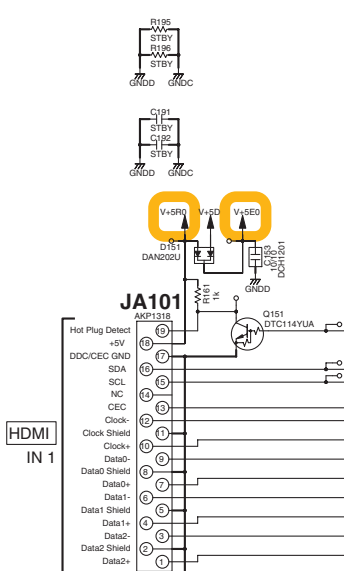
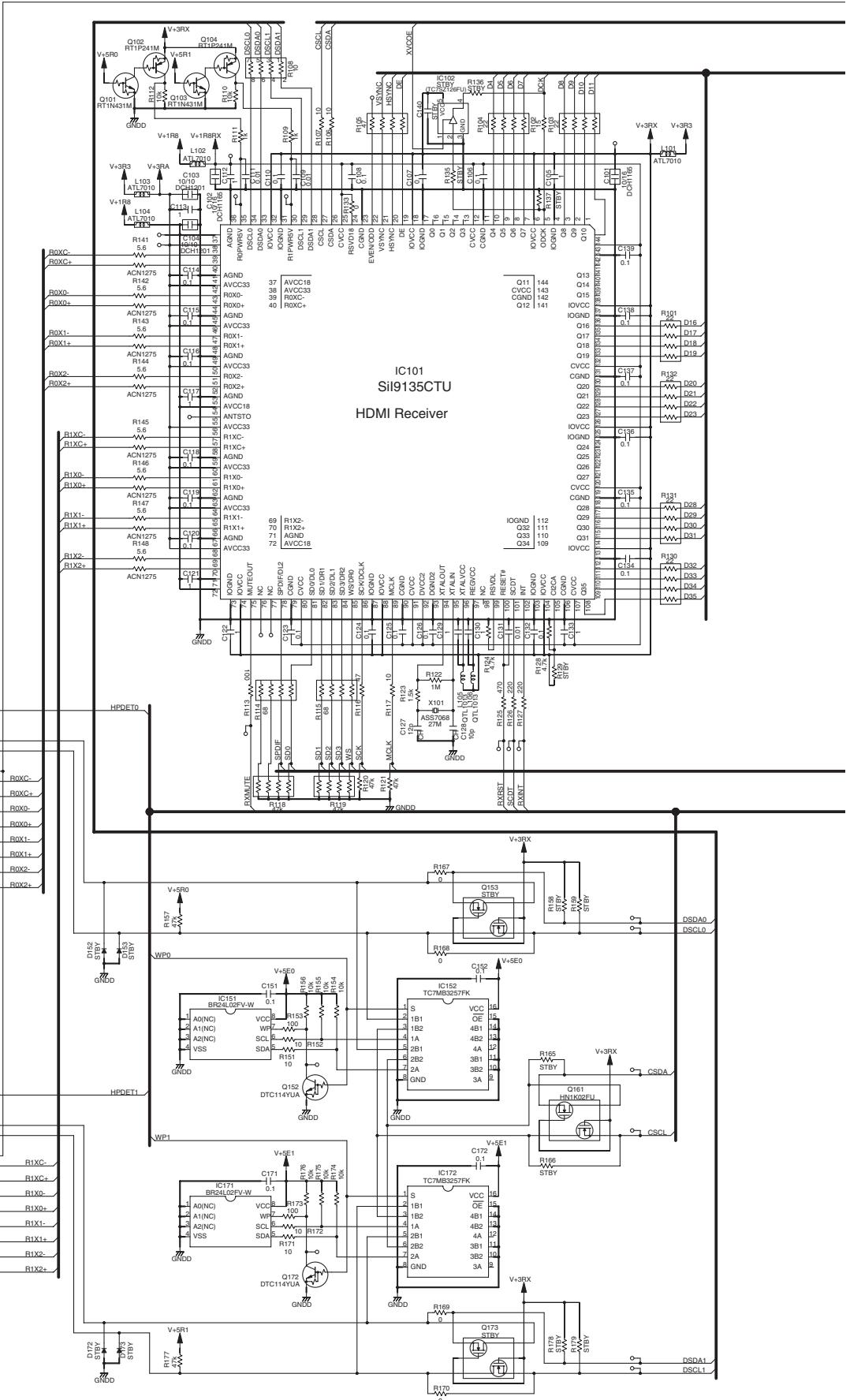

## AK 1/2



# 10.21 HDMI & DVC ASSY (2/2)

AK 1/2

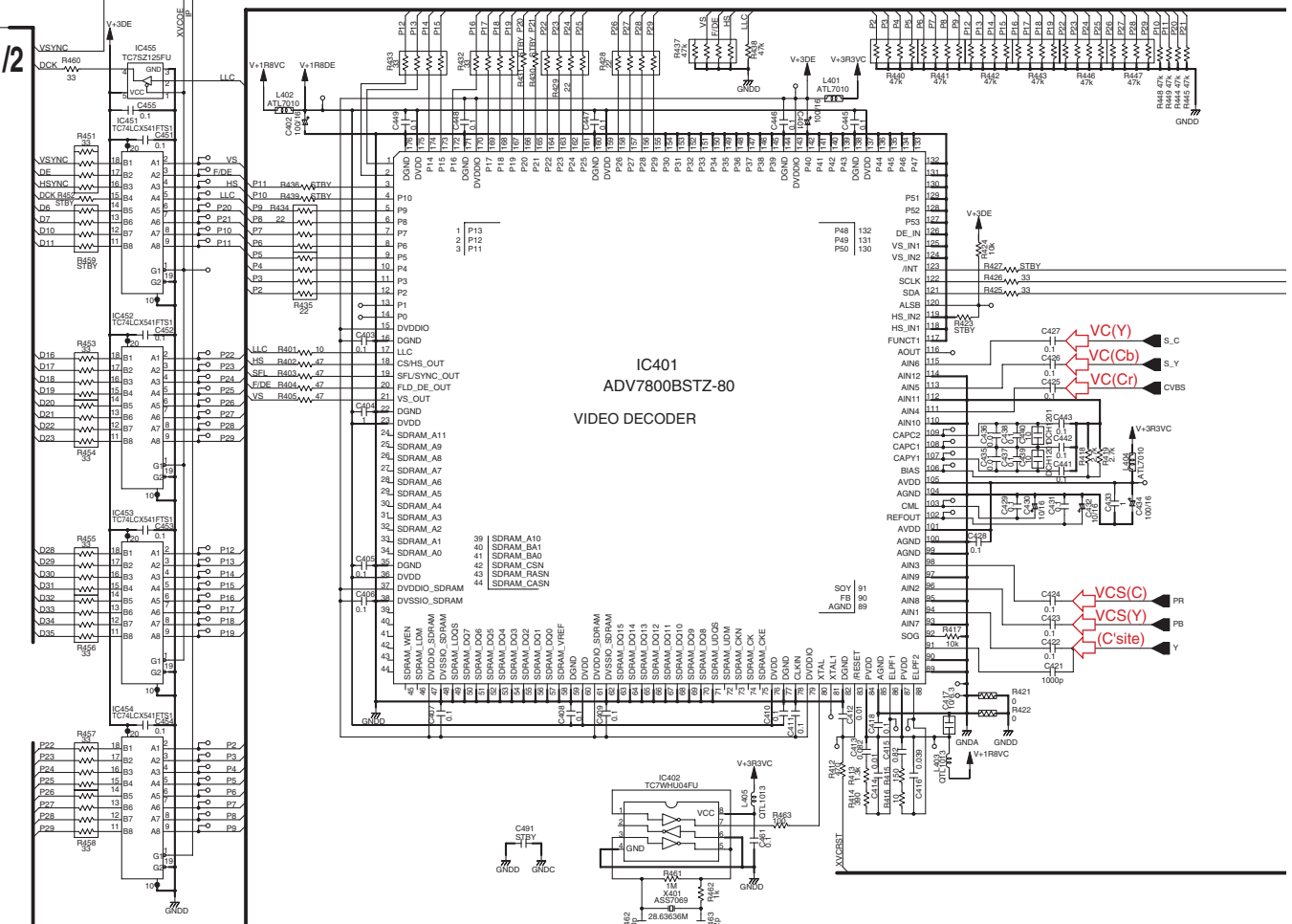
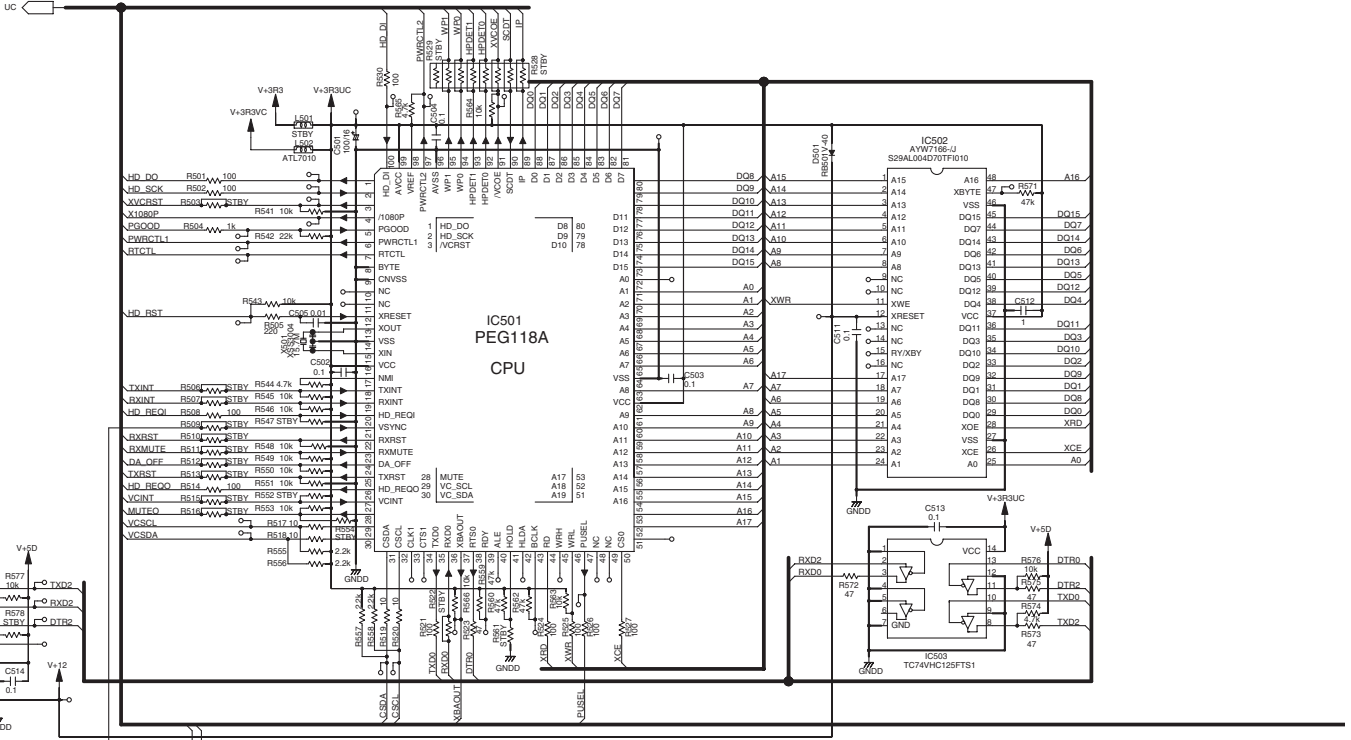

AK 2/2



# 10.22 USB ASSY (VSX-LX50 ONLY)

## AL USB ASSY (AWX8866)

A  
B  
C  
D  
E  
F

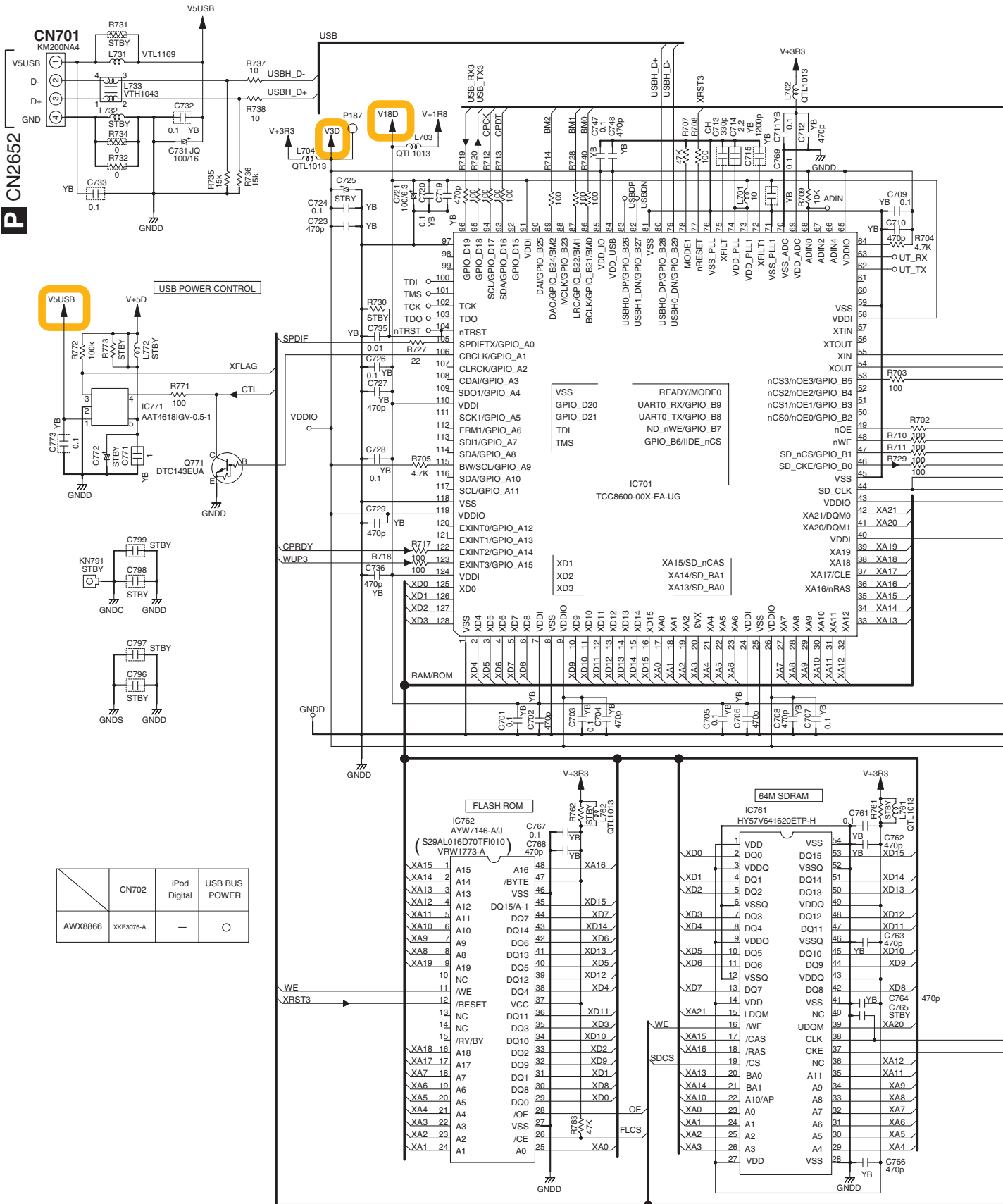

	CN702	iPod Digital	USB BUS POWER
AWX8866	XKP3076-A	-	○

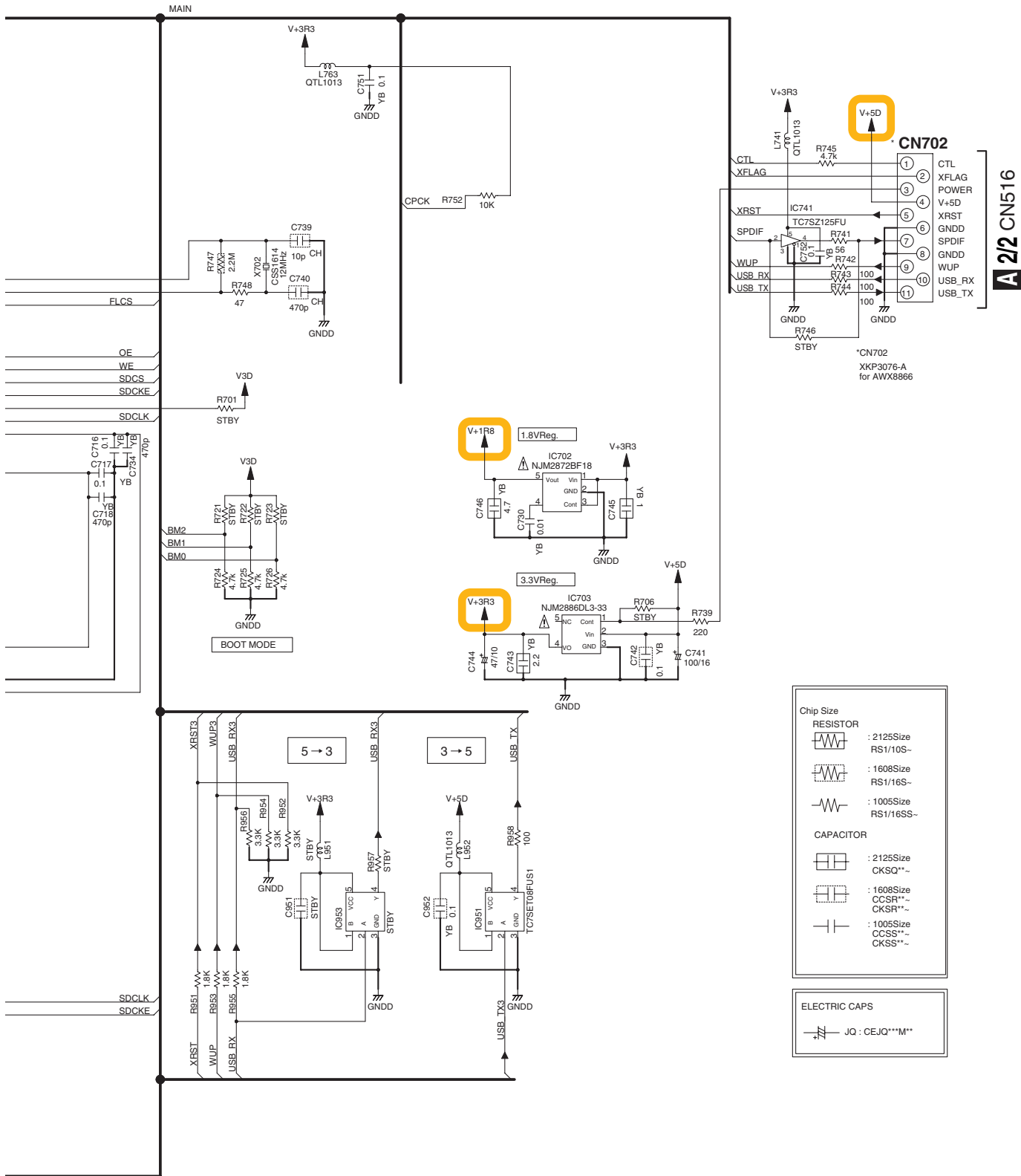

A

B

C

D







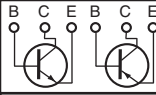

E

F

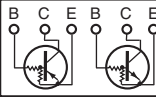
# 11. PCB CONNECTION DIAGRAM

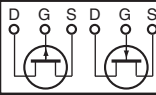
## NOTE FOR PCB DIAGRAMS :

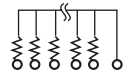
1. Part numbers in PCB diagrams match those in the schematic diagrams.
2. A comparison between the main parts of PCB and schematic diagrams is shown below.

Symbol In PCB Diagrams	Symbol In Schematic Diagrams	Part Name
		Transistor
		Transistor with resistor
		Field effect transistor
		Resistor array
		3-terminal regulator

3. The parts mounted on this PCB include all necessary parts for several destinations.  
For further information for respective destinations, be sure to check with the schematic diagram.
4. View point of PCB diagrams.

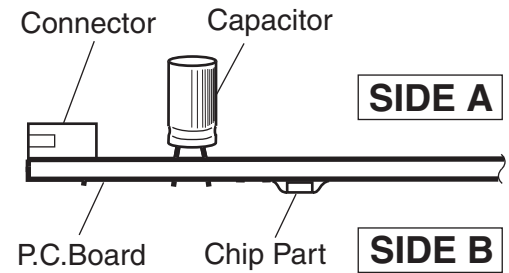

# 11.1 AUDIO IN ASSY

**SIDE A**

A  
B  
C  
D  
E  
F

220  
210  
200  
190  
180  
170  
160  
150  
140  
130  
120  
110  
100  
90  
80  
70  
60  
50  
40  
30  
20  
10  
0

## A AUDIO IN ASSY

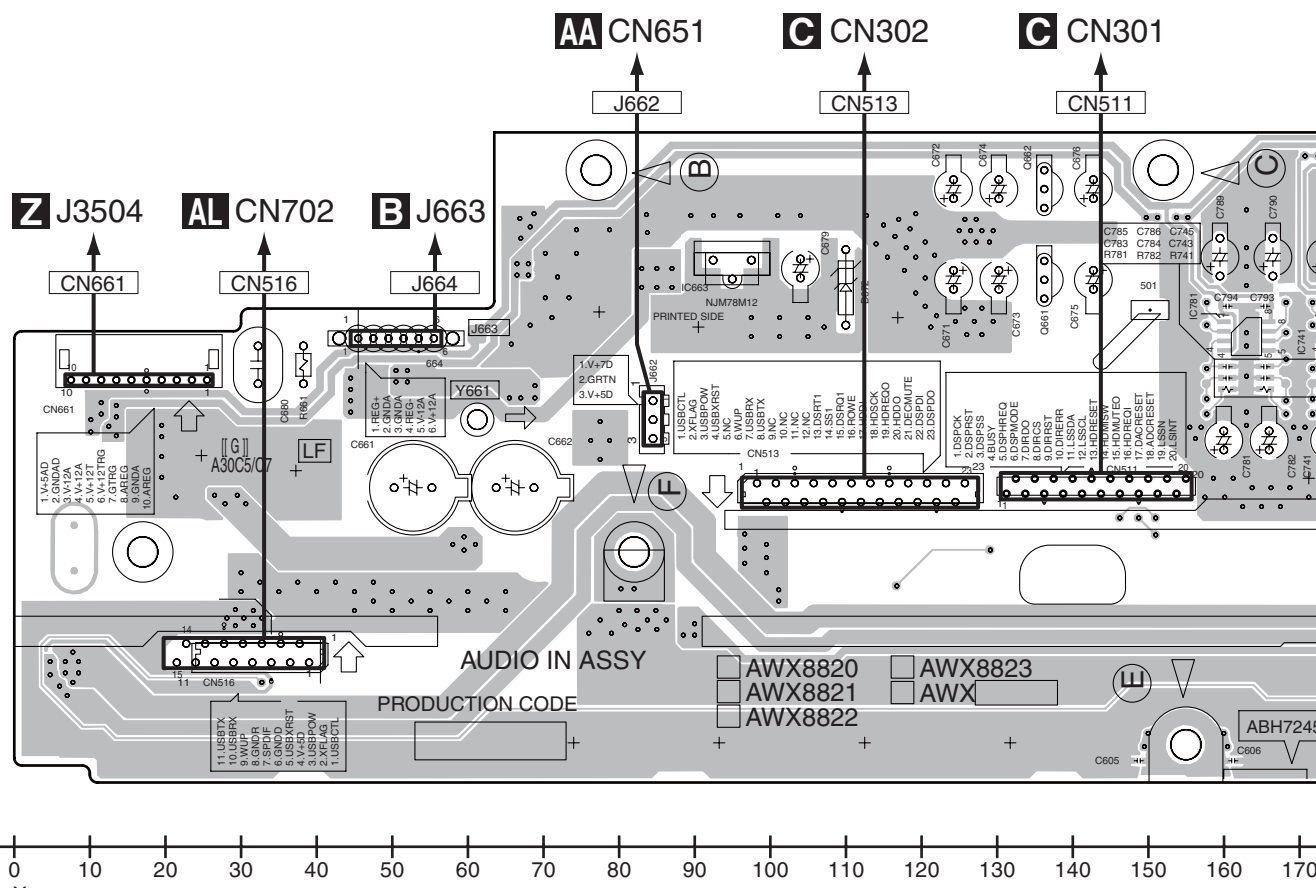

X →

**A**

SIDE A

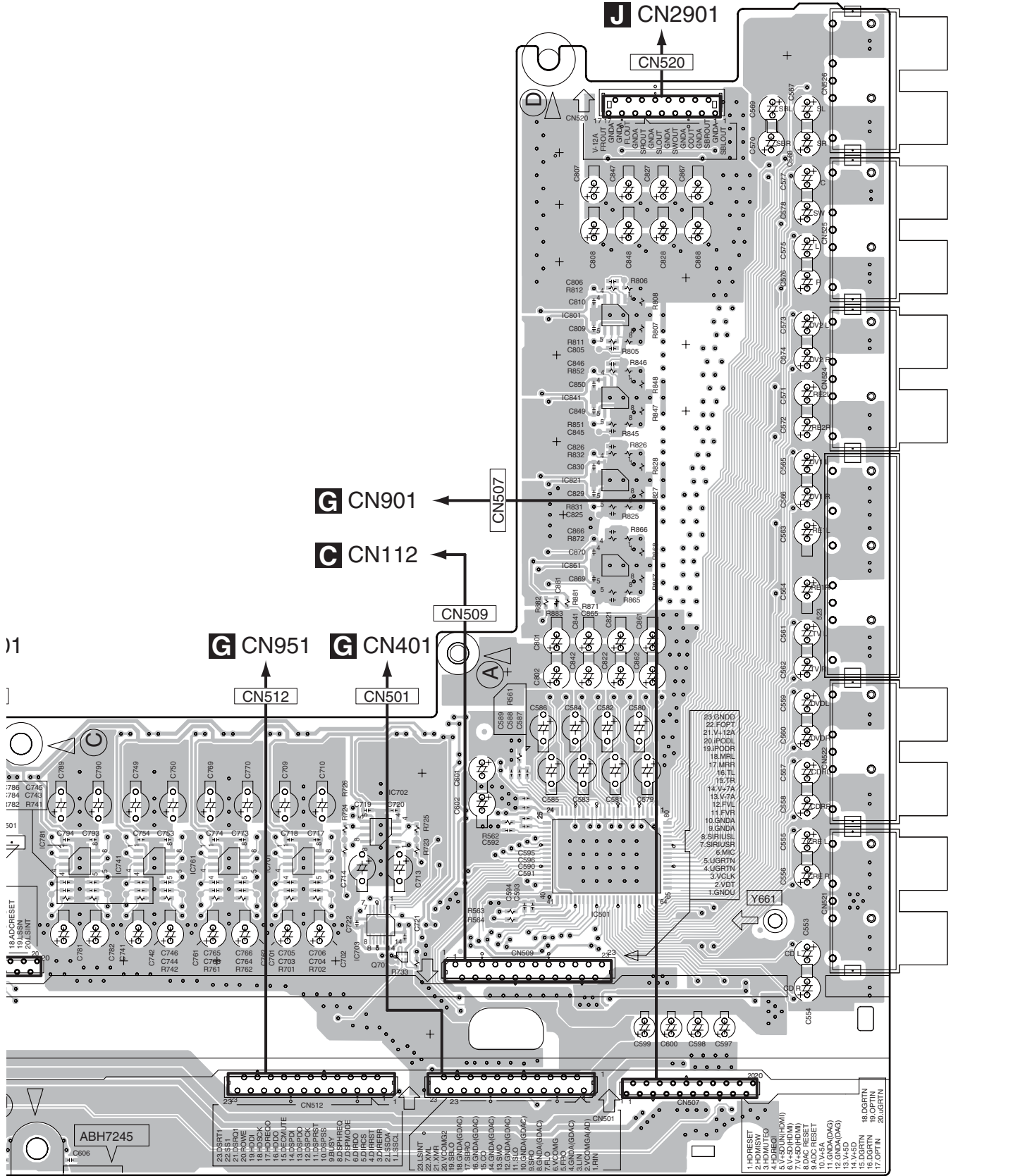

1)

]

50 160 170 180 190 200 210 220 230 240 250 260 270 280 290 300 310 320

A  
B  
C  
D  
E  
F

ABH7245

(ANP7596-B)

VSX-LX50

A

SIDE B

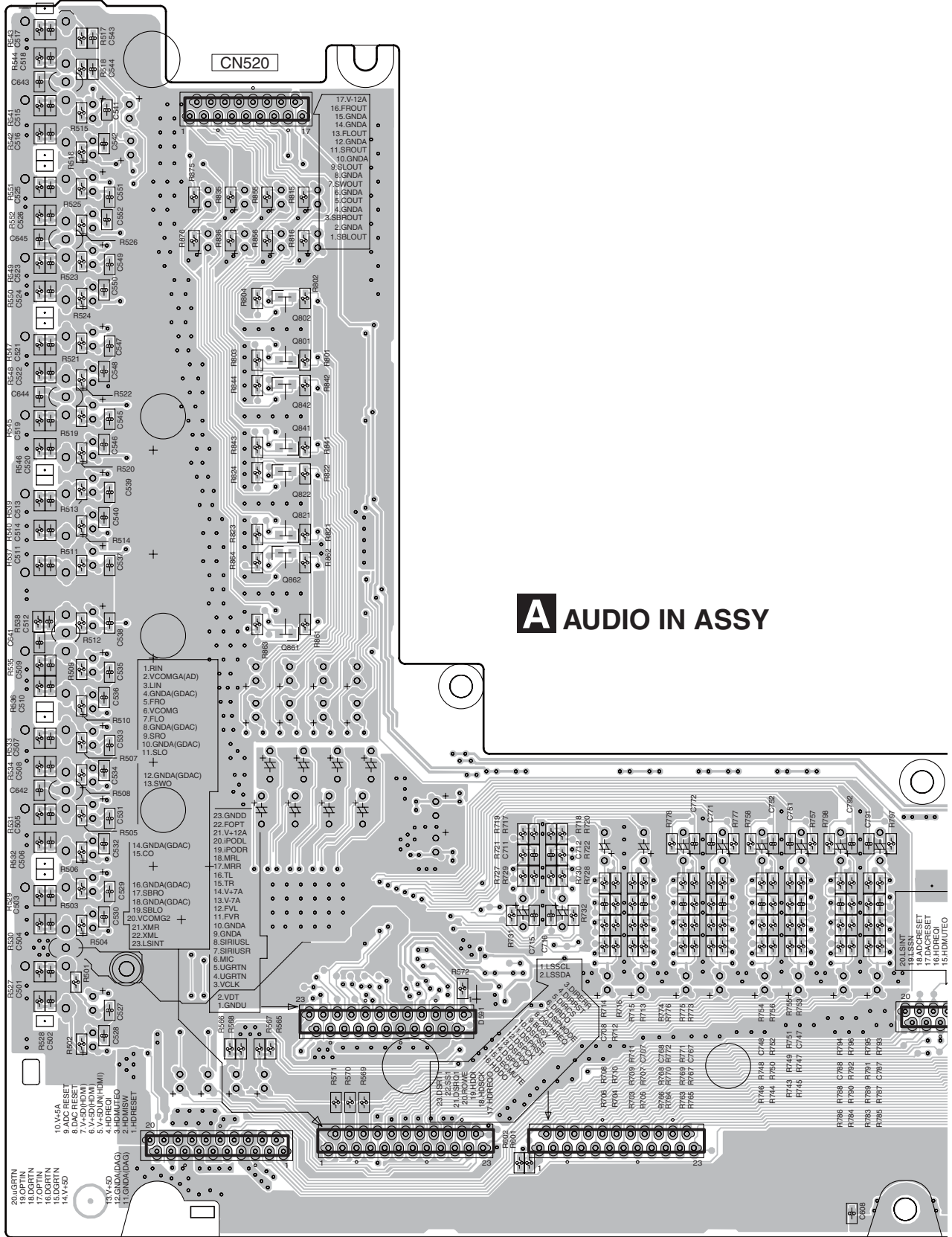

A AUDIO IN ASSY

(ANP7596-B)

CN507

CN509

CN501

CN512

C

320 310 300 290 280 270 260 250 240 230 220 210 200 190 180 170 160 150

A

150

VSX-LX50

SIDE B

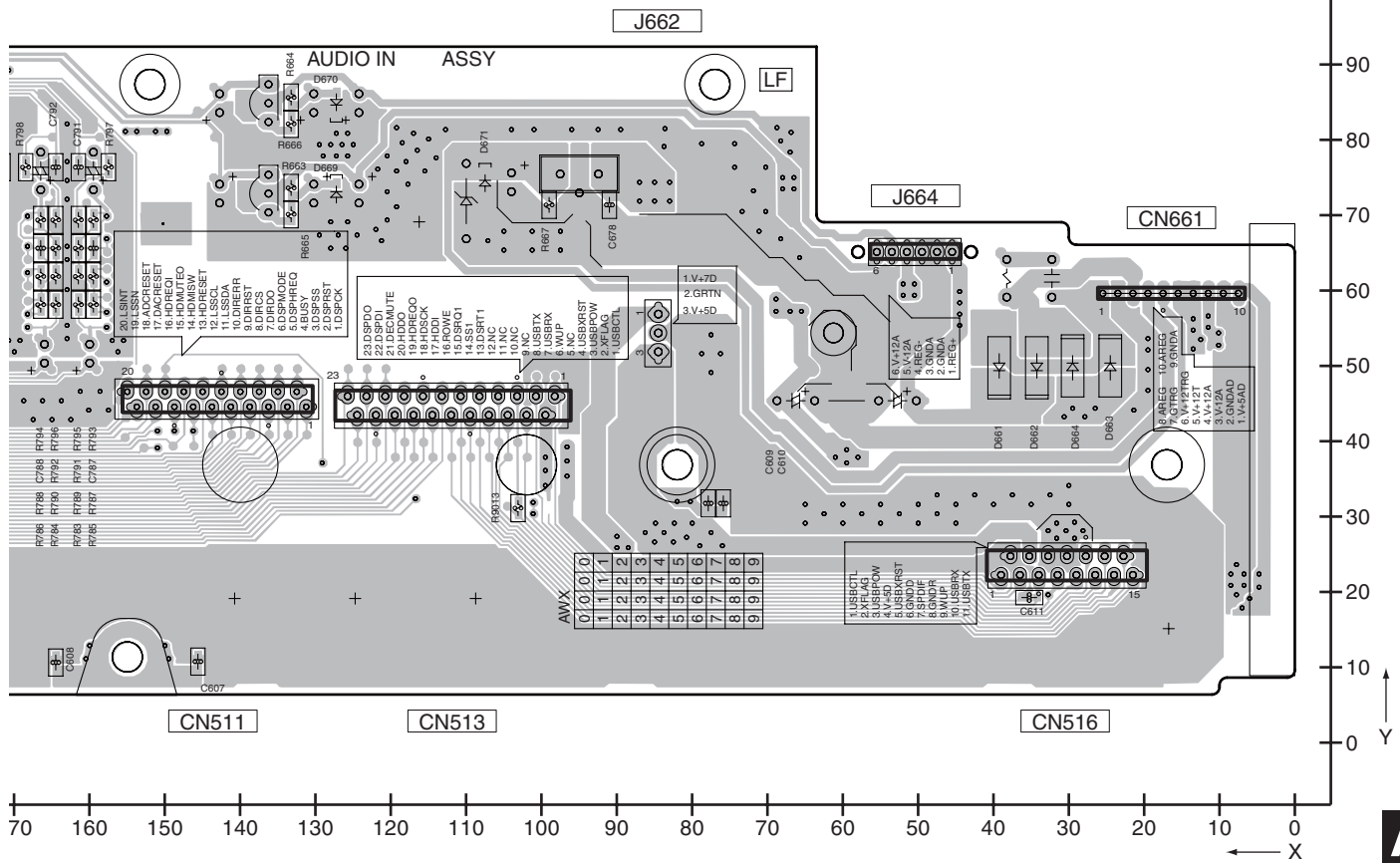

A  
B  
C  
D  
E  
F

220  
210  
200  
190  
180  
170  
160  
150  
140  
130  
120  
110  
100  
90  
80  
70  
60  
50  
40  
30  
20  
10  
0 Y

70 160 150 140 130 120 110 100 90 80 70 60 50 40 30 20 10 0 X

VSX-LX50

A

# 11.2 12V-REG ASSY

**SIDE A**

**SIDE A**

## **B** 12V-REG ASSY

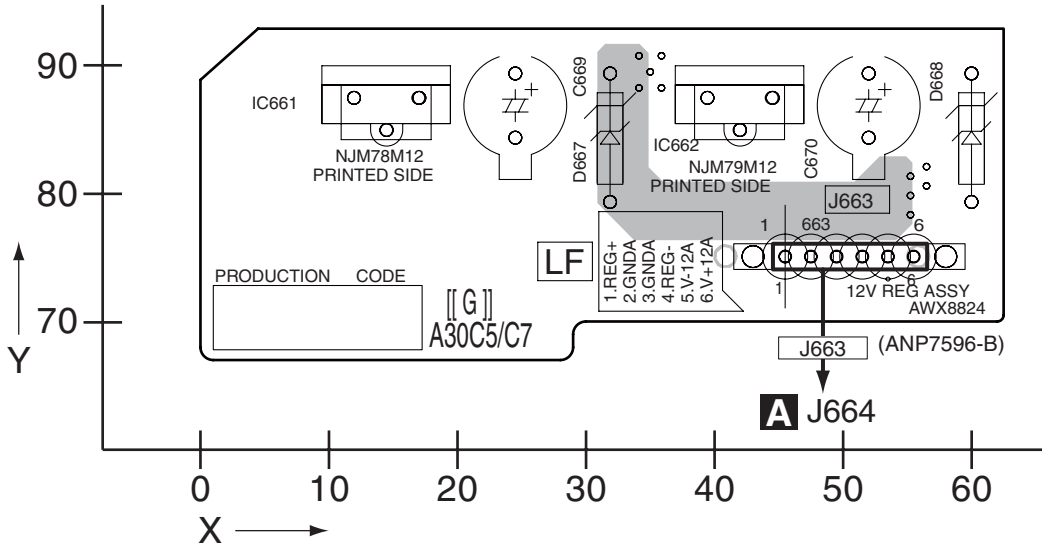

**SIDE B**

**SIDE B**

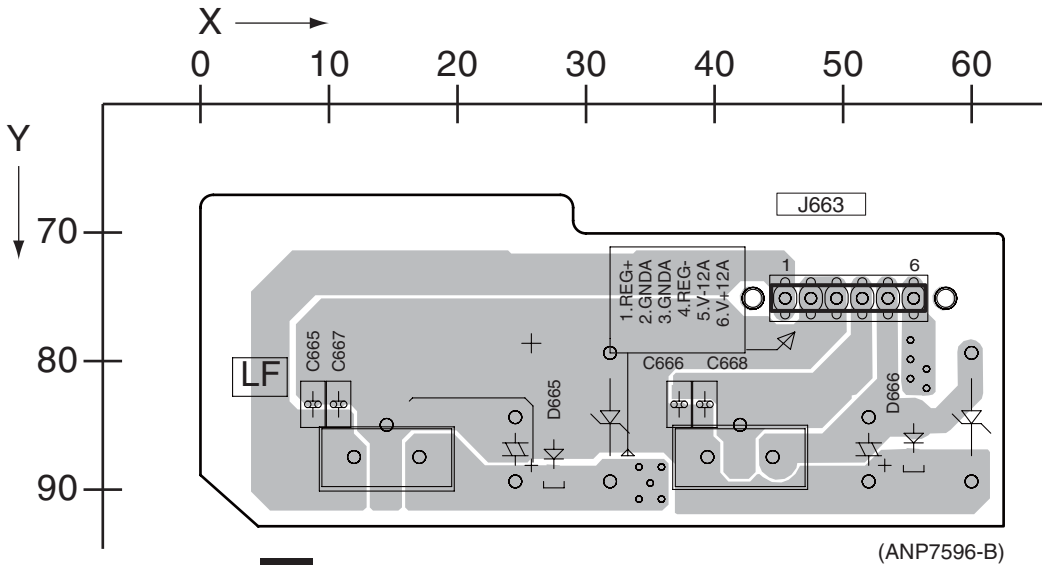

## **B** 12V-REG ASSY

**B**

**B**

# 11.3 BRIDGE 2 ASSY

**SIDE A**

**SIDE A**

## J BRIDGE 2 ASSY

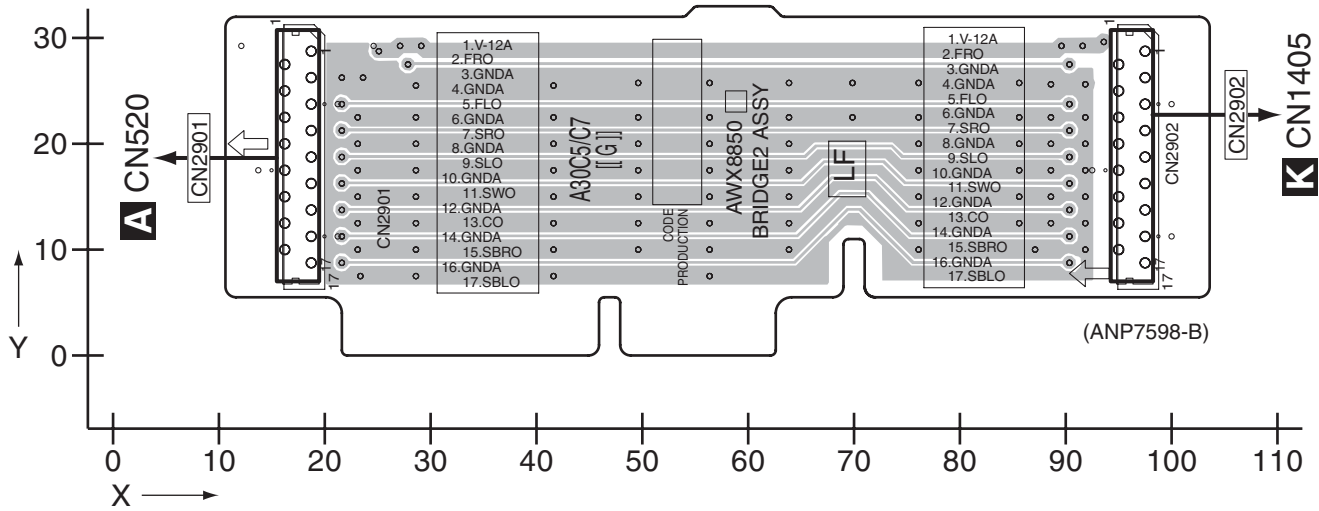

**SIDE B**

**SIDE B**

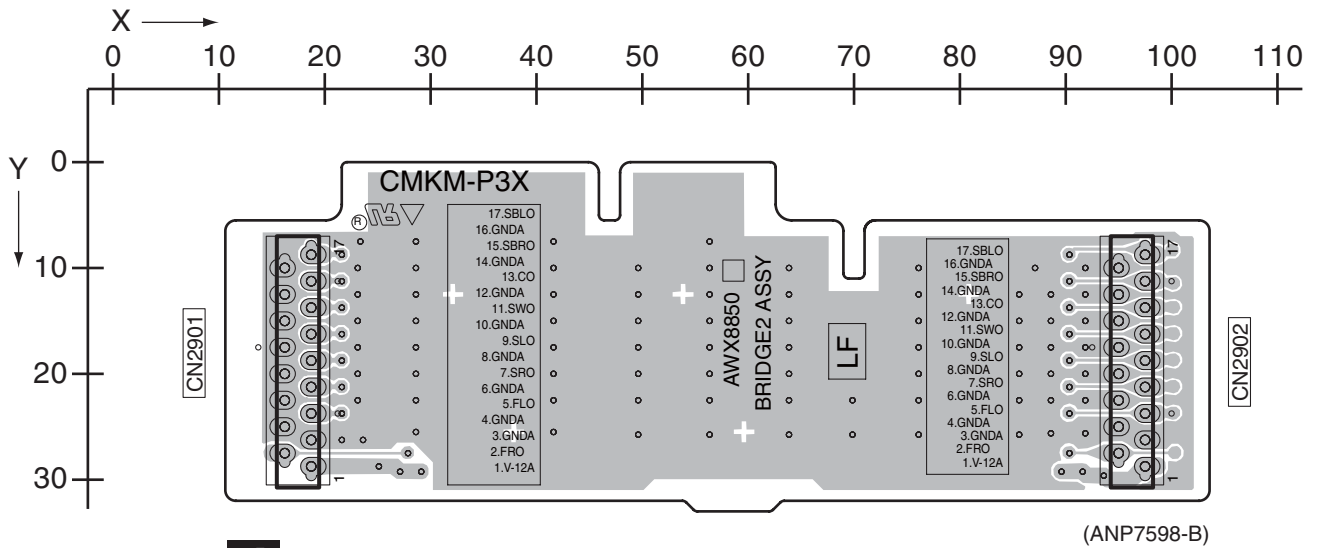

## J BRIDGE 2 ASSY

**J**

**J**

# 11.4 MAIN CONTROL ASSY

**SIDE A**

## C MAIN CONTROL ASSY

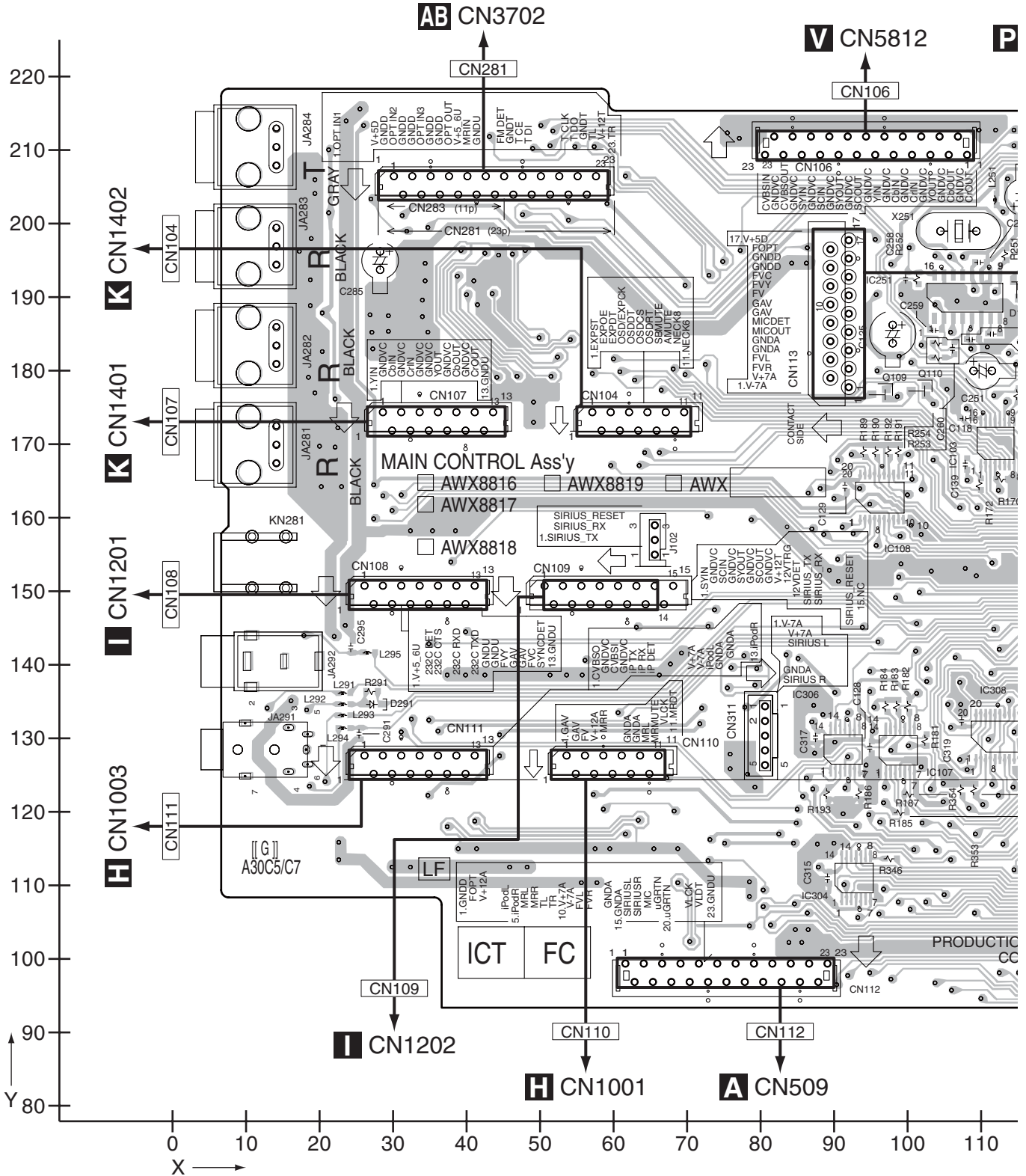

**SIDE A**

A

B

C

D

E

F

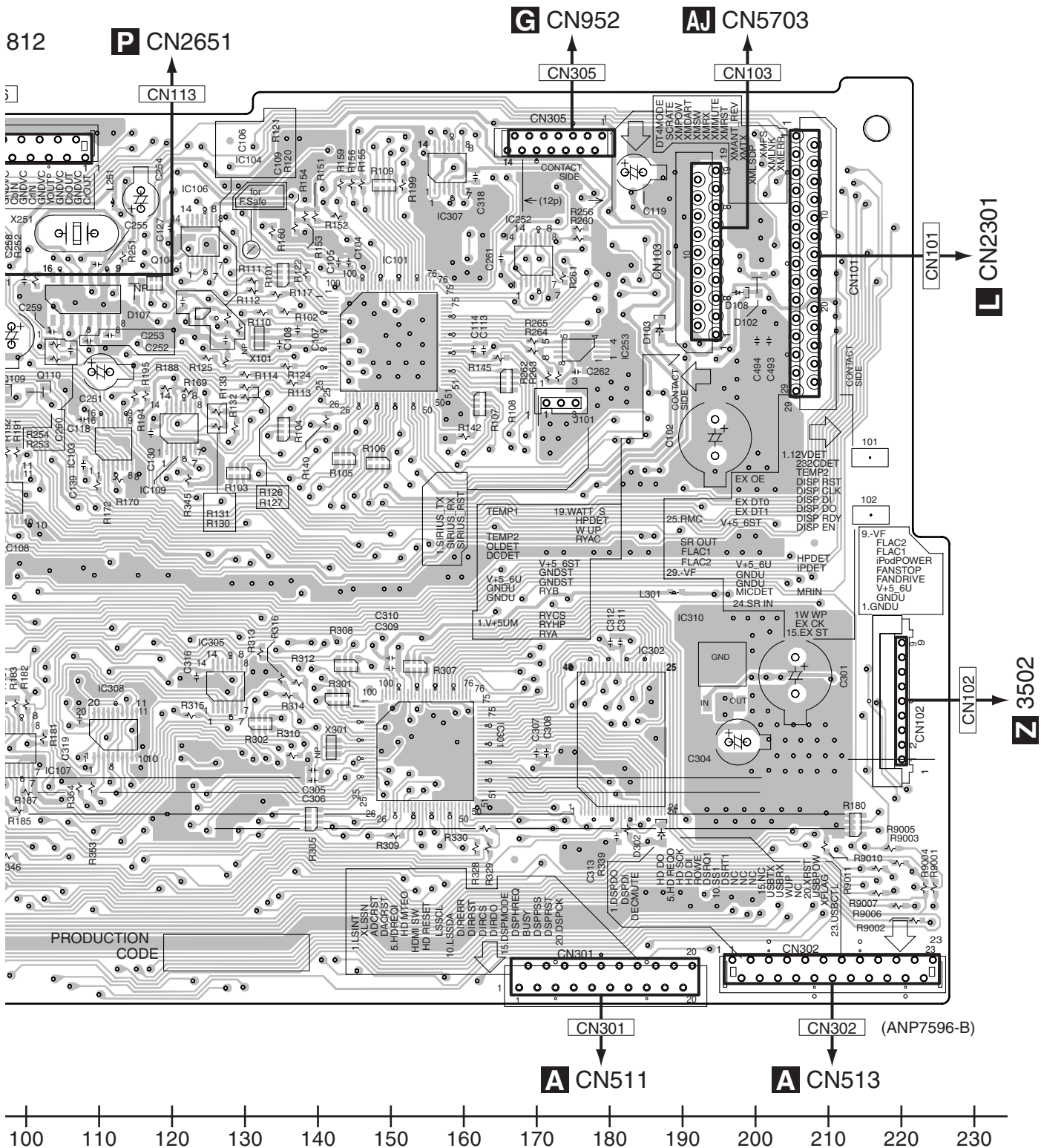

**C**

SIDE B

# C MAIN CONTROL ASSY

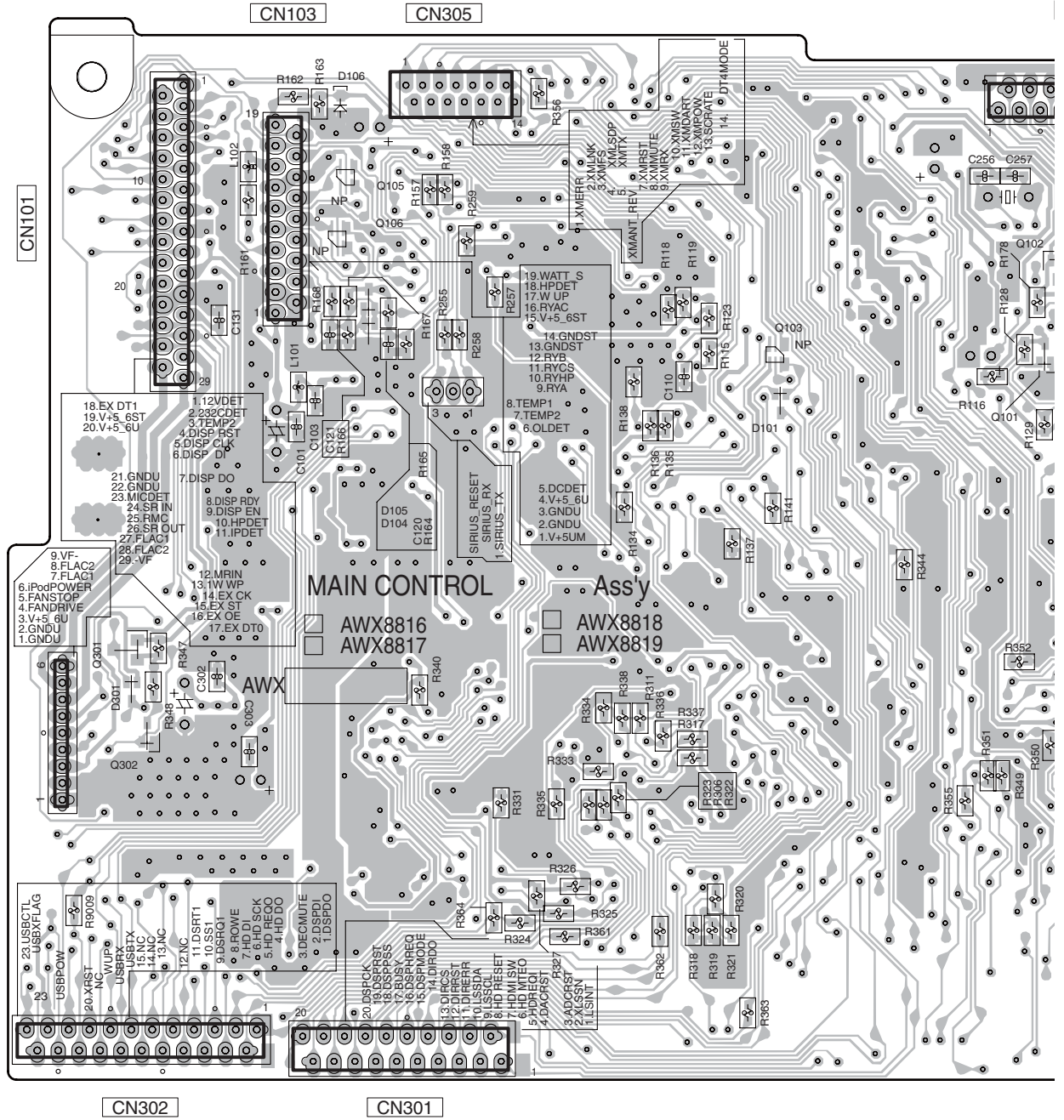

C

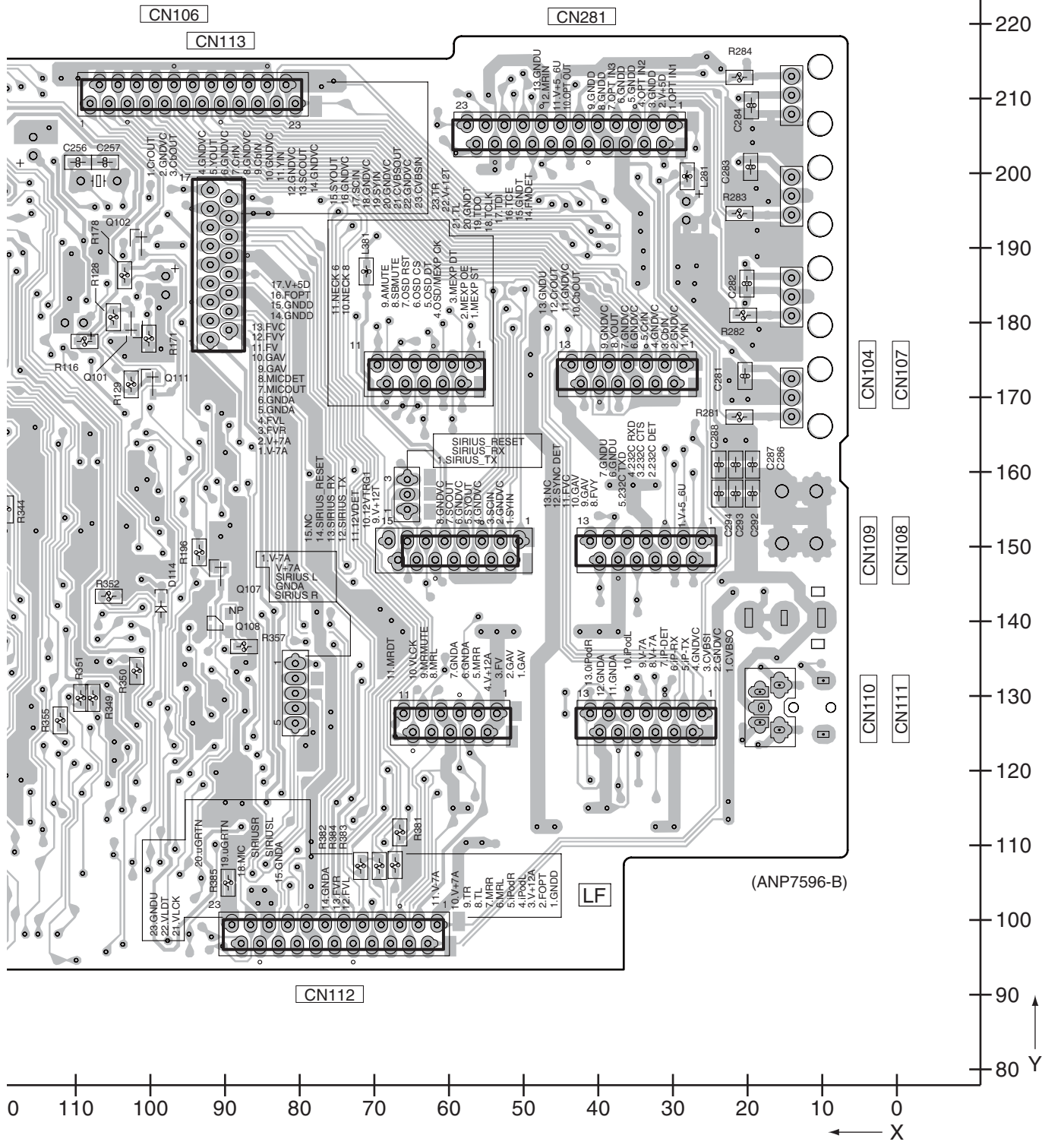

VSX-LX50



**SIDE A**

A

B

C

D

E

F

**G**

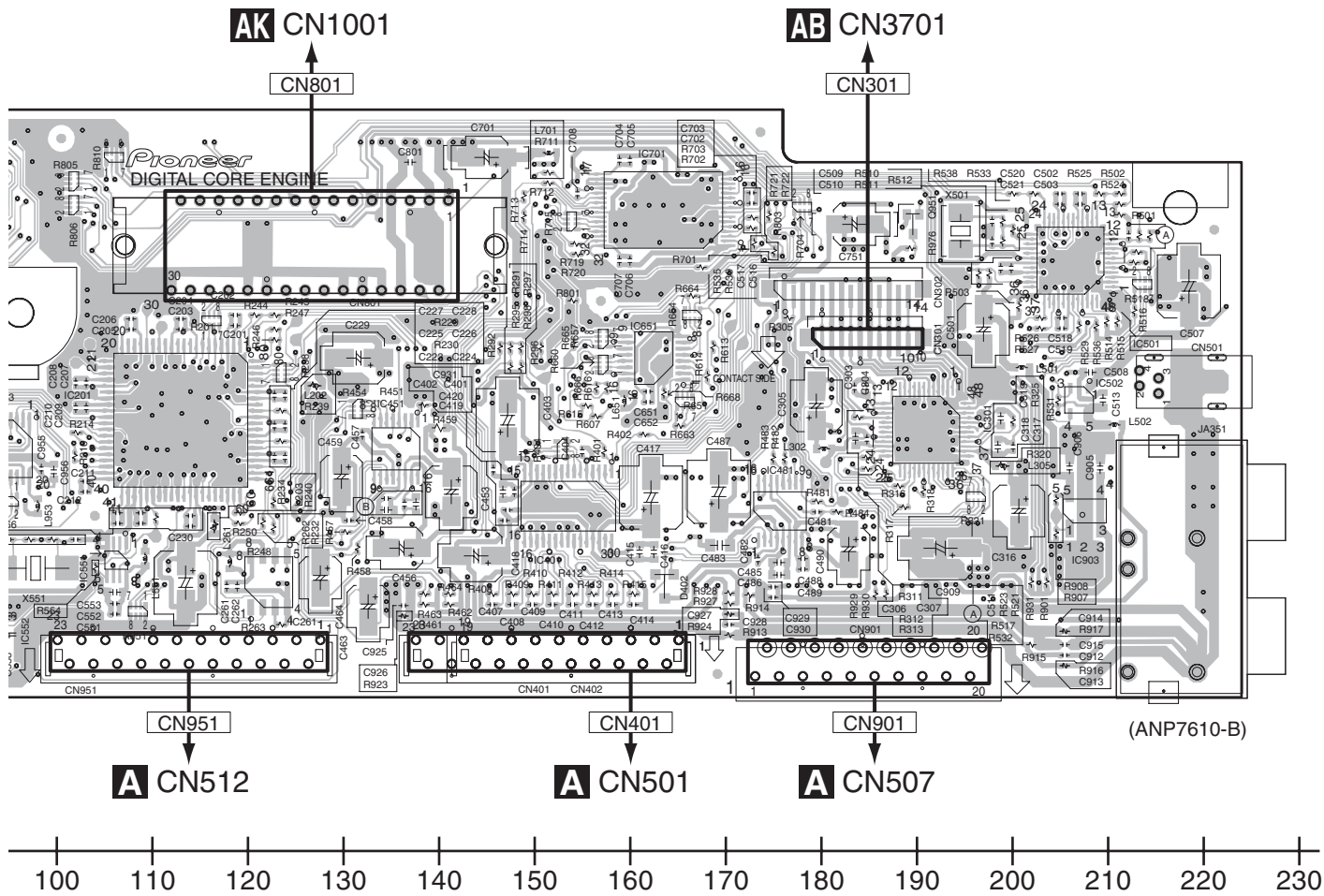

SIDE B

**G** DSP ASSY

CN801

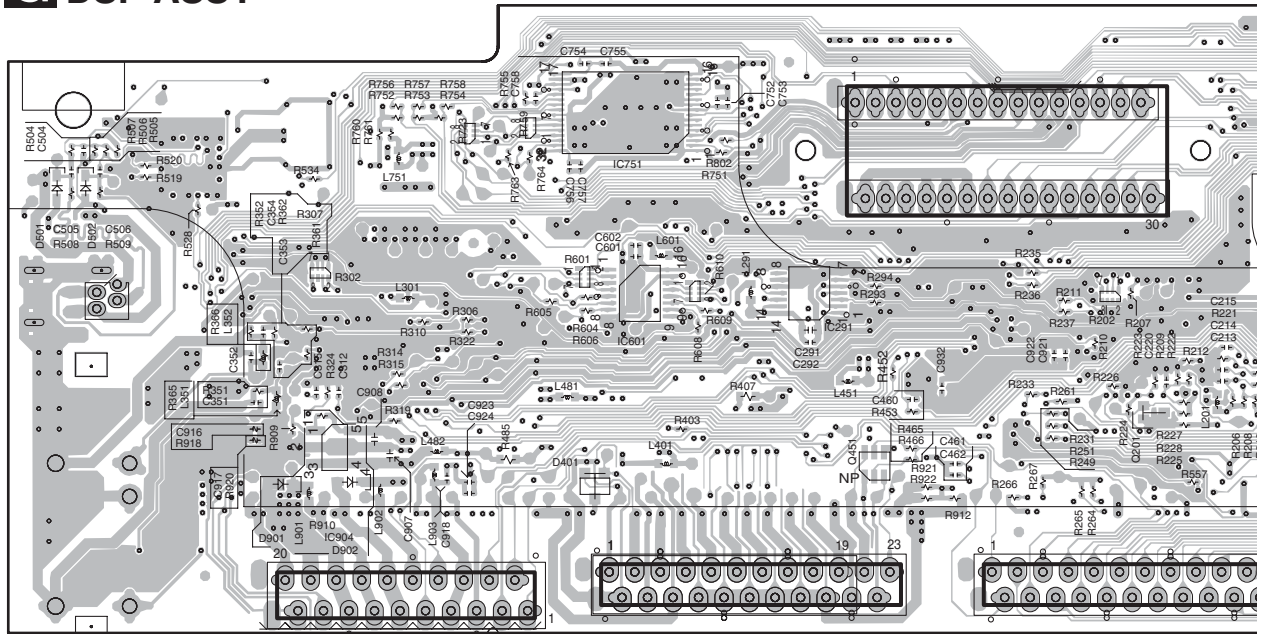

CN901

CN401

CN951

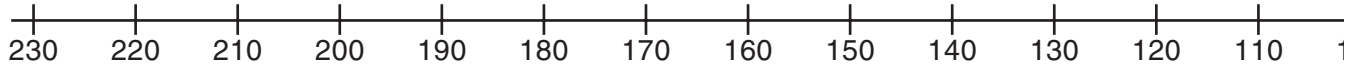

SIDE B

A

B

C

D

E

F

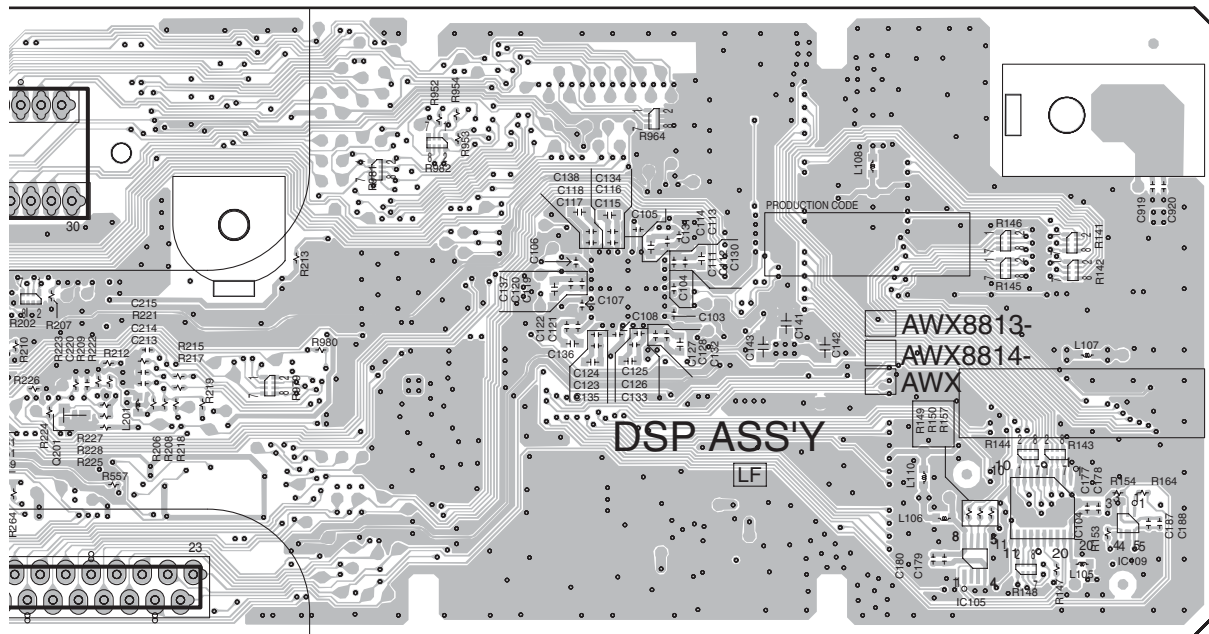

CN951

(ANP7610-B)

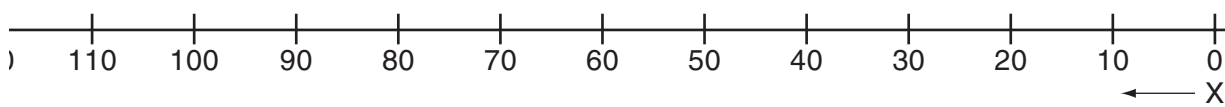



SIDE A

CR OUT    DVR IN    DVR OUT    TV IN    DVD IN

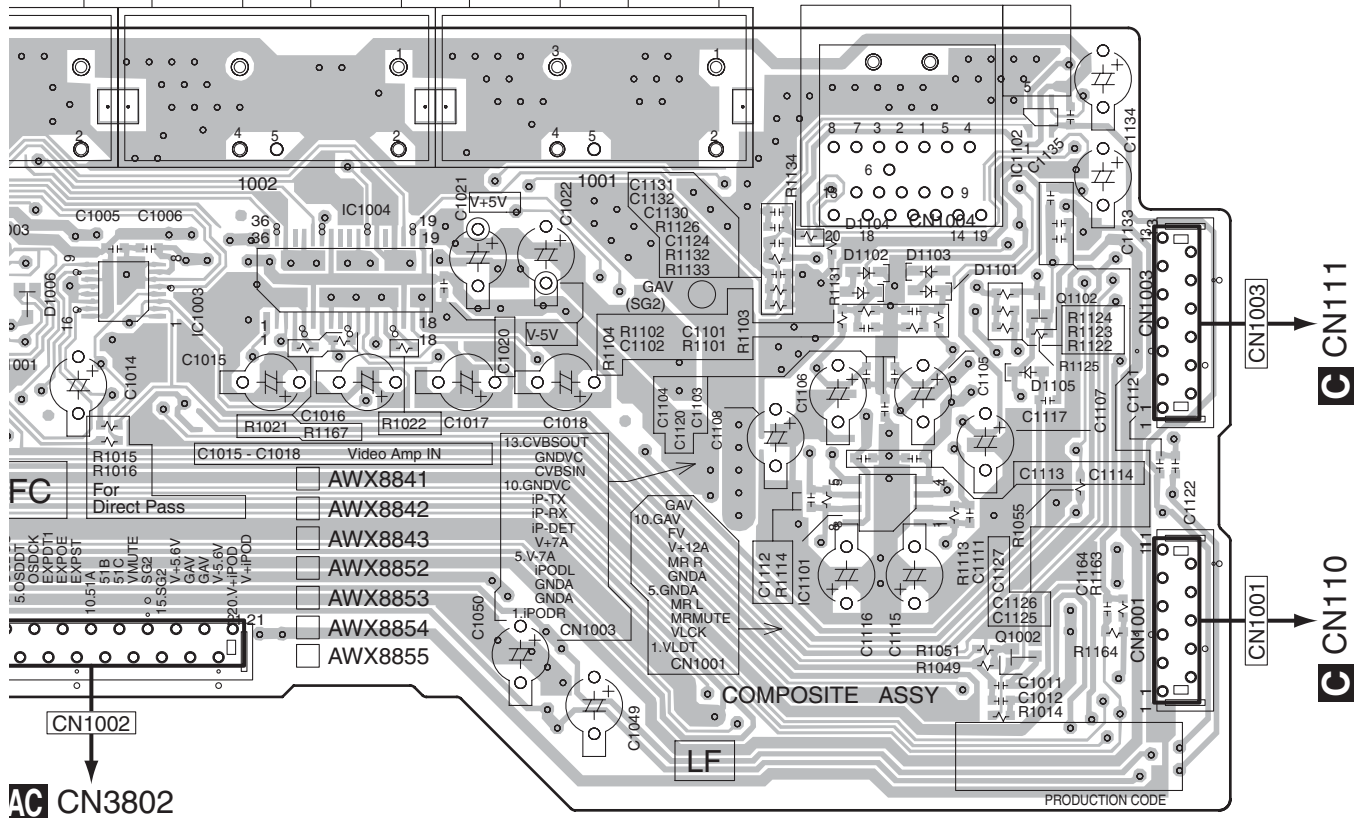

(ANP7598-B)

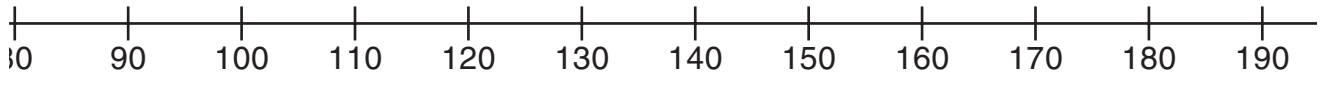

SIDE B

# COMPOSITE ASSY

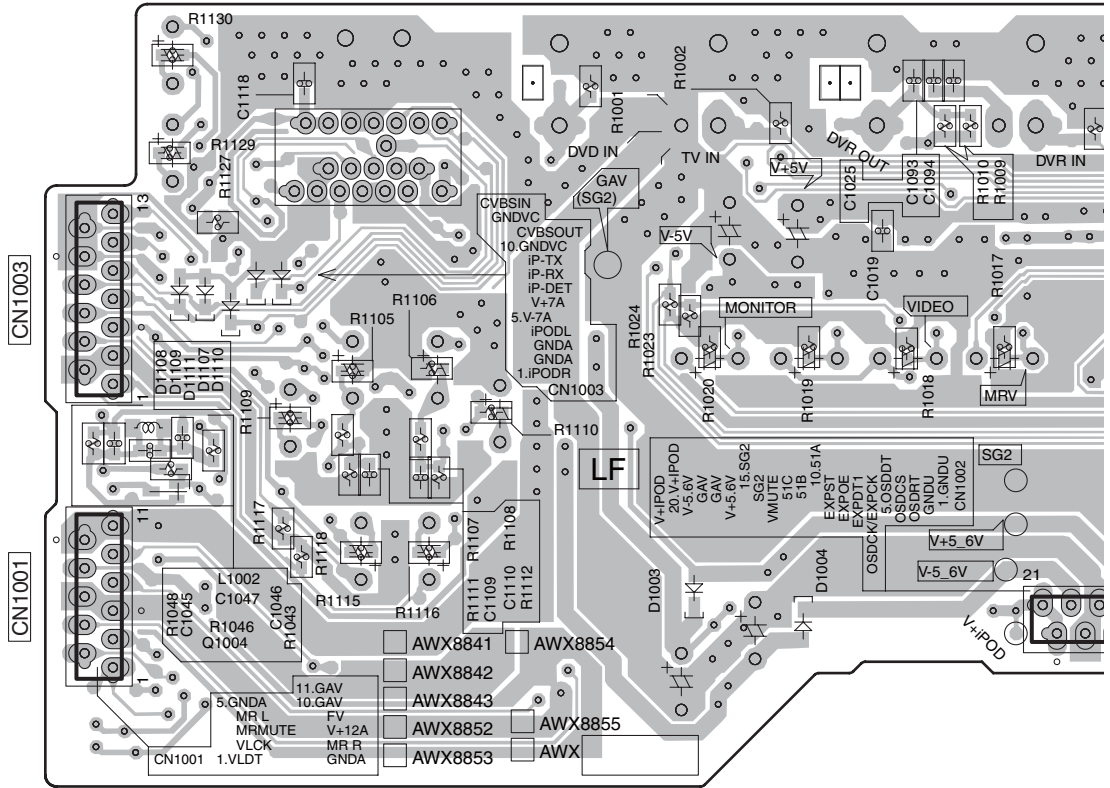

(ANP7598-B)

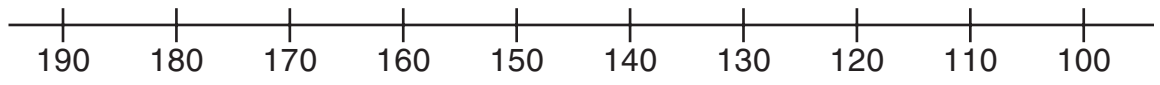

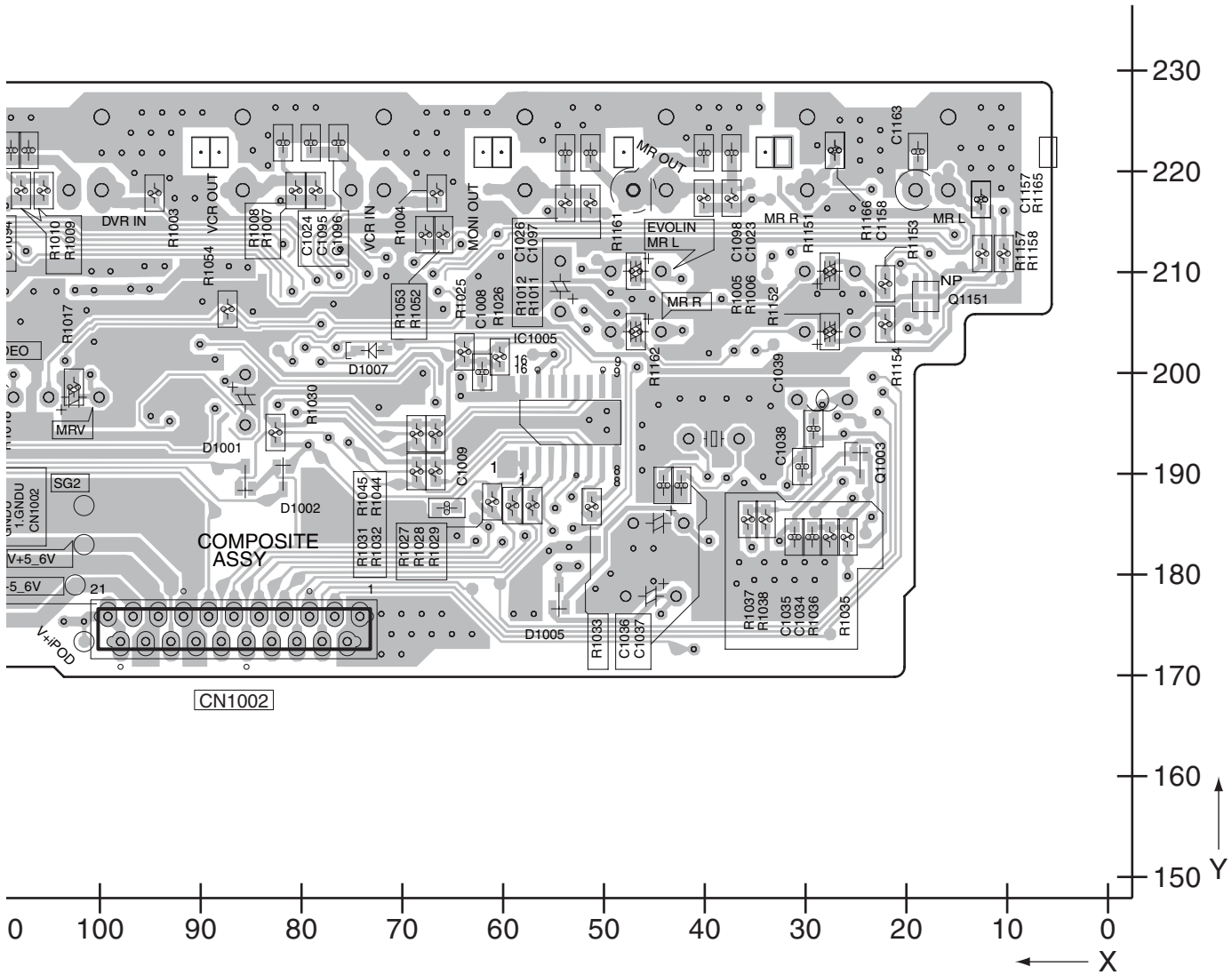

# 11.7 S-VIDEO ASSY

**SIDE A**

## S-VIDEO ASSY

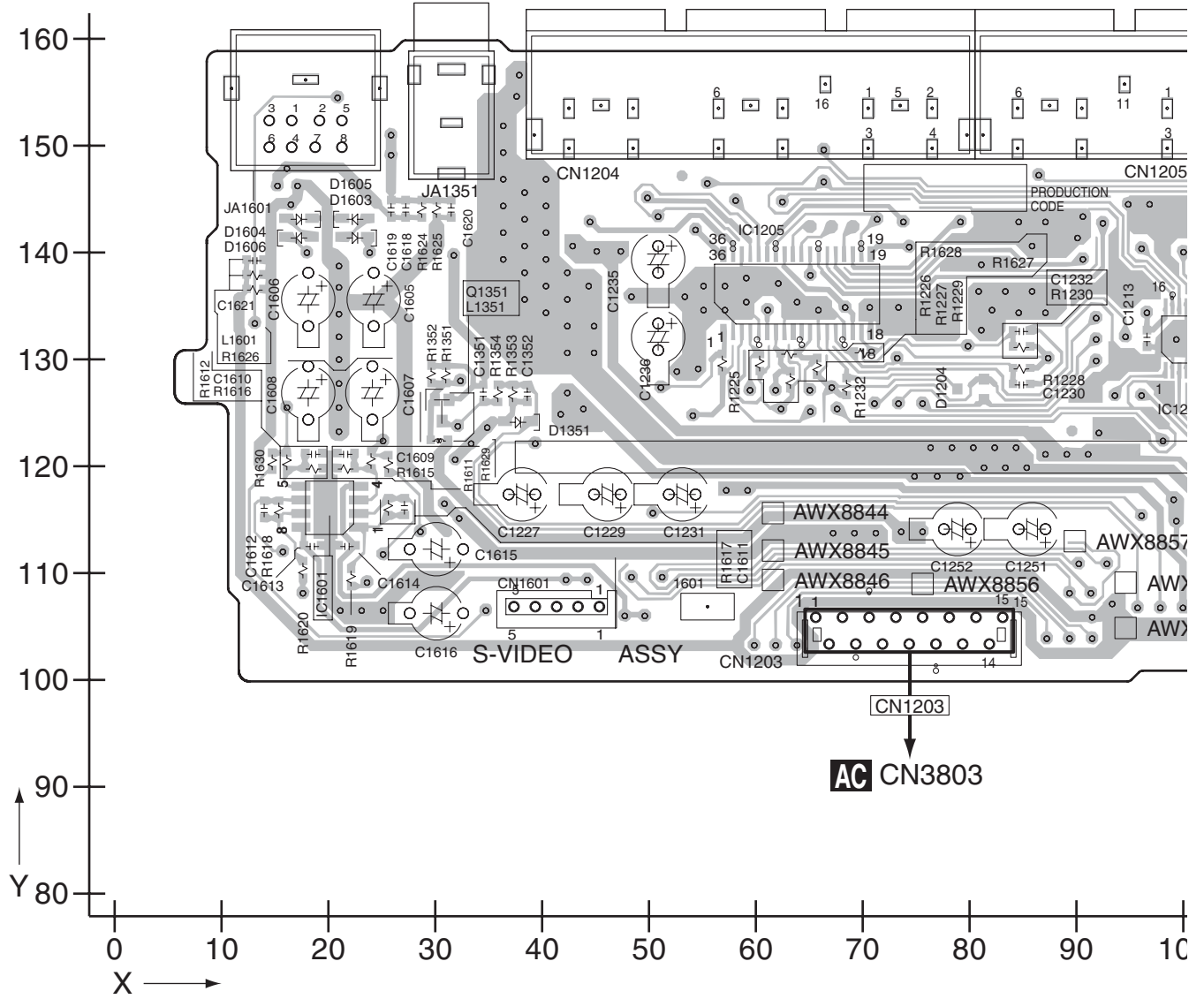



SIDE B

# S-VIDEO ASSY

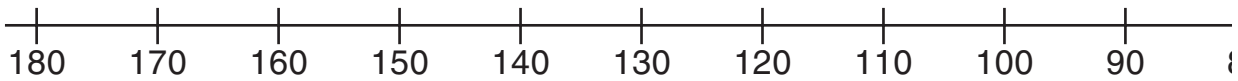
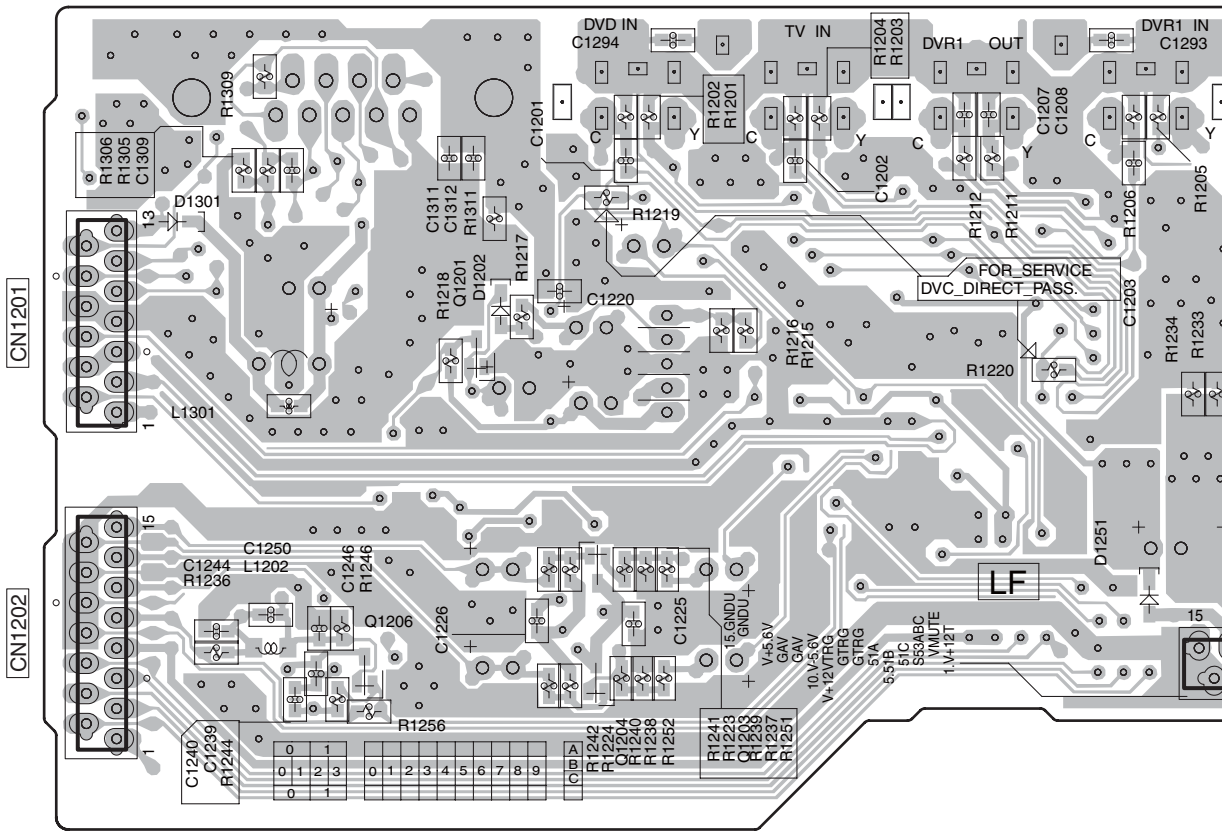

**SIDE B**

A

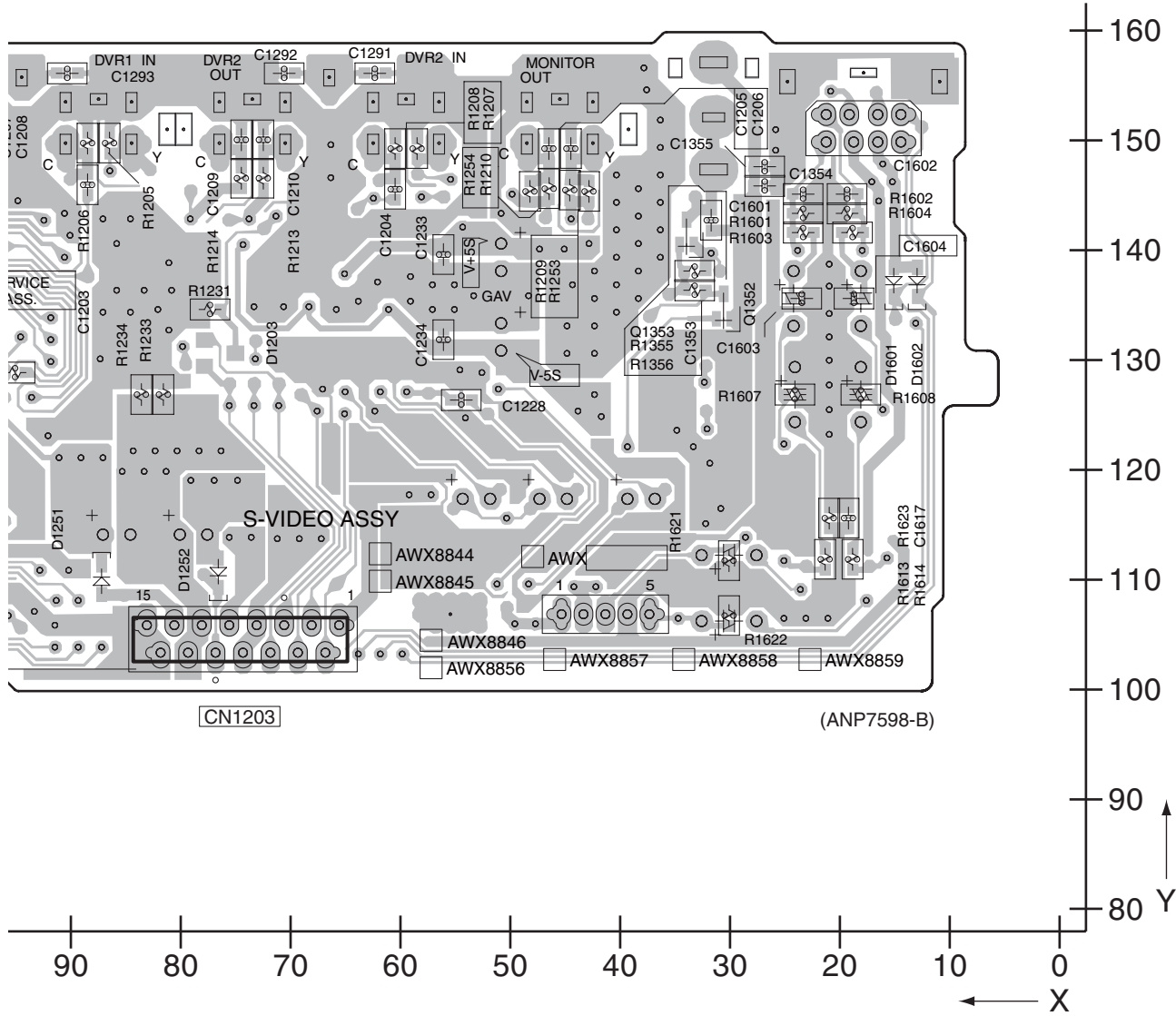

B

C

D

E

F



# 11.8 COMPONENT ASSY

SIDE A

## K COMPONENT ASSY

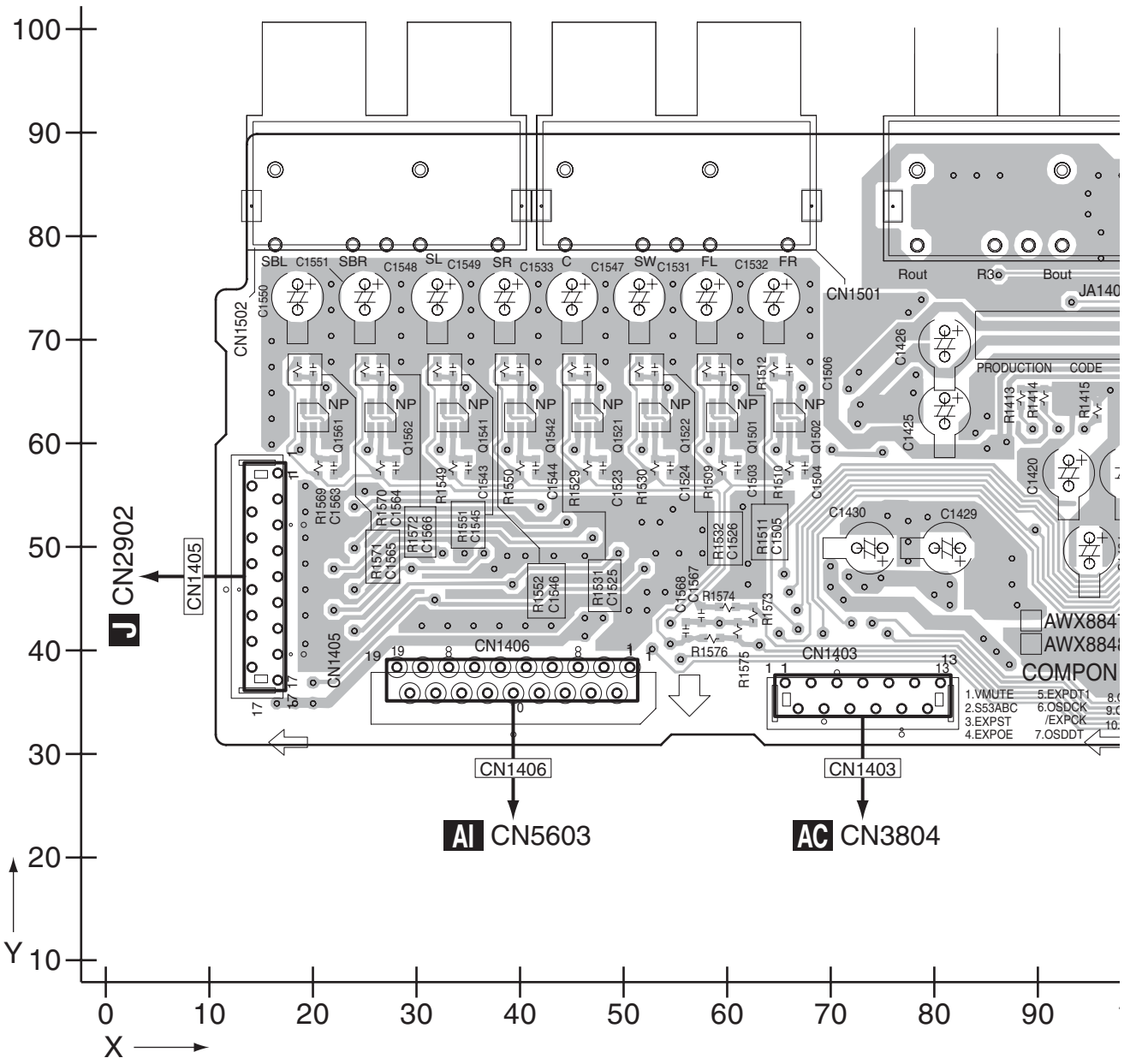

# K

SIDE A

A

B

C

D

E

F

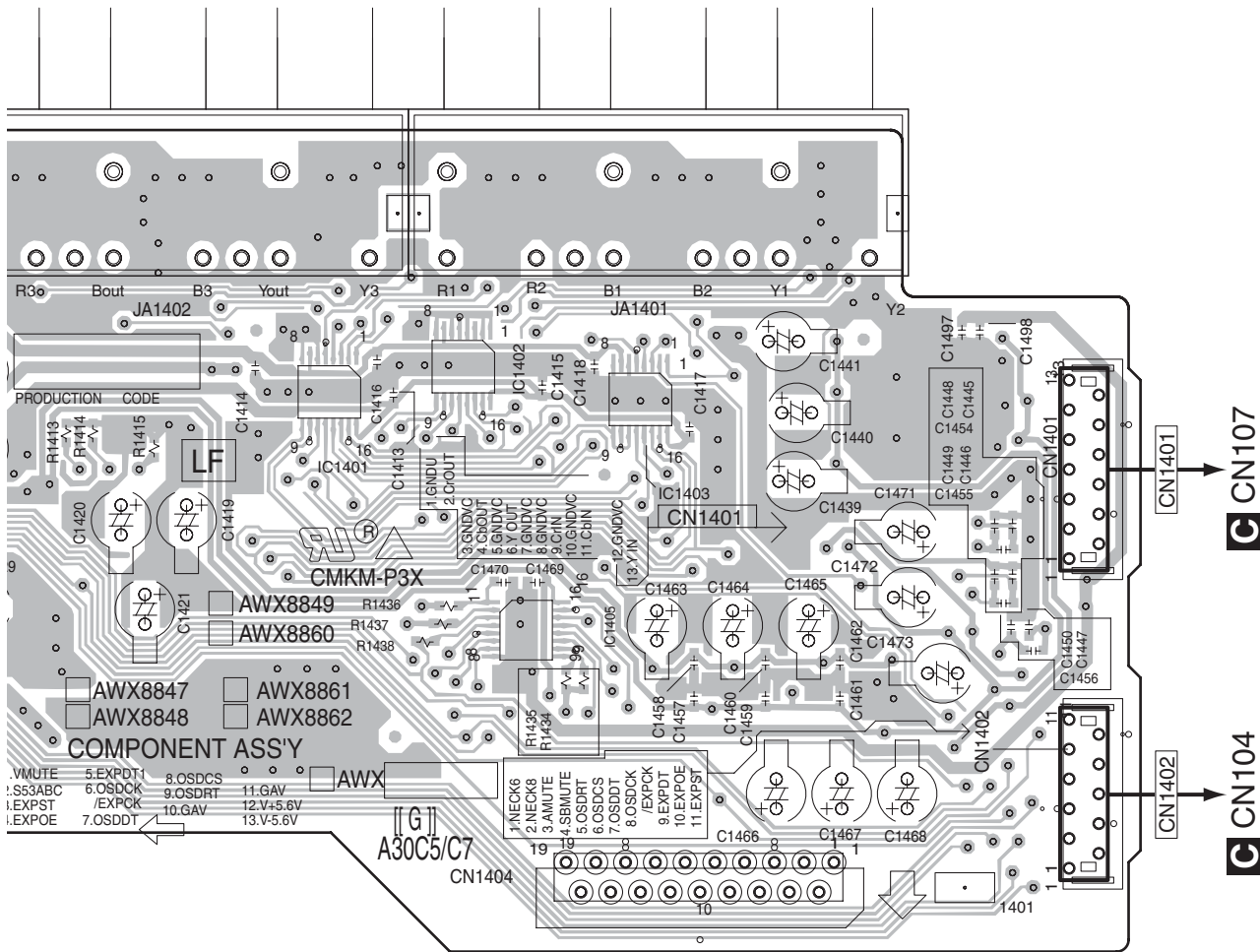

COMPONENT ASS'Y

1.VMUTE	5.EXPDT1	8.OSDCS	11.GAV
2.S63ABC	6.OSDCK	9.OSDRT	12.V+5.6V
3.EXPST	7.OSDDT	10.GAV	13.V-5.6V
4.EXPST			

- AWX8847
- AWX8848
- AWX8849
- AWX8860
- AWX8861
- AWX8862
- AWX

- 1.NECK6
- 2.NECK8
- 3.AMUTE
- 4.SBMUTE
- 5.OSDRT
- 6.OSDCS
- 7.OSDDT
- 8.OSDCK
- 9.EXPDT
- 10.EXPOE
- 11.EXPST

A30C5/C7  
CN1404

CMKM-P3X

PRODUCTION CODE

JA1402

JA1401

LF

AWX8847

AWX8848

AWX8849

AWX8860

AWX8861

AWX8862

AWX

1.NECK6

2.NECK8

3.AMUTE

4.SBMUTE

5.OSDRT

6.OSDCS

7.OSDDT

8.OSDCK

9.EXPDT

10.EXPOE

11.EXPST

A30C5/C7

CMKM-P3X

PRODUCTION CODE

JA1402

JA1401

LF

AWX8847

AWX8848

AWX8849

AWX8860

AWX8861

AWX8862

AWX

1.NECK6

2.NECK8

3.AMUTE

4.SBMUTE

5.OSDRT

6.OSDCS

7.OSDDT

8.OSDCK

9.EXPDT

10.EXPOE

11.EXPST

A30C5/C7

CMKM-P3X

PRODUCTION CODE

JA1402

JA1401

LF

AWX8847

AWX8848

AWX8849

AWX8860

AWX8861

AWX8862

AWX

1.NECK6

2.NECK8

3.AMUTE

4.SBMUTE

5.OSDRT

6.OSDCS

7.OSDDT

8.OSDCK

9.EXPDT

10.EXPOE

11.EXPST

A30C5/C7

CMKM-P3X

PRODUCTION CODE

JA1402

JA1401

LF

AWX8847

AWX8848

AWX8849

AWX8860

AWX8861

AWX8862

AWX

1.NECK6

2.NECK8

3.AMUTE

4.SBMUTE

5.OSDRT

6.OSDCS

7.OSDDT

8.OSDCK

9.EXPDT

10.EXPOE

11.EXPST

A30C5/C7

CMKM-P3X

PRODUCTION CODE

JA1402

JA1401

LF

AWX8847

AWX8848

AWX8849

AWX8860

AWX8861

AWX8862

AWX

1.NECK6

2.NECK8

3.AMUTE

4.SBMUTE

5.OSDRT

6.OSDCS

7.OSDDT

8.OSDCK

9.EXPDT

10.EXPOE

11.EXPST

A30C5/C7

CMKM-P3X

PRODUCTION CODE

JA1402

JA1401

LF

AWX8847

AWX8848

AWX8849

AWX8860

AWX8861

AWX8862

AWX

1.NECK6

2.NECK8

3.AMUTE

4.SBMUTE

5.OSDRT

6.OSDCS

7.OSDDT

8.OSDCK

9.EXPDT

10.EXPOE

11.EXPST

A30C5/C7

CMKM-P3X

PRODUCTION CODE

JA1402

JA1401

LF

AWX8847

AWX8848

AWX8849

AWX8860

AWX8861

AWX8862

AWX

1.NECK6

2.NECK8

3.AMUTE

4.SBMUTE

5.OSDRT

6.OSDCS

7.OSDDT

8.OSDCK

9.EXPDT

10.EXPOE

11.EXPST

A30C5/C7

CMKM-P3X

PRODUCTION CODE

JA1402

JA1401

LF

AWX8847

AWX8848

AWX8849

AWX8860

AWX8861

AWX8862

AWX

1.NECK6

2.NECK8

3.AMUTE

4.SBMUTE

5.OSDRT

6.OSDCS

7.OSDDT

8.OSDCK

9.EXPDT

10.EXPOE

11.EXPST

A30C5/C7

CMKM-P3X

PRODUCTION CODE

JA1402

JA1401

LF

AWX8847

AWX8848

AWX8849

AWX8860

AWX8861

AWX8862

AWX

1.NECK6

2.NECK8

3.AMUTE

4.SBMUTE

5.OSDRT

6.OSDCS

7.OSDDT

8.OSDCK

9.EXPDT

10.EXPOE

11.EXPST

A30C5/C7

CMKM-P3X

PRODUCTION CODE

JA1402

JA1401

LF

AWX8847

AWX8848

AWX8849

AWX8860

AWX8861

AWX8862

AWX

1.NECK6

2.NECK8

3.AMUTE

4.SBMUTE

5.OSDRT

6.OSDCS

7.OSDDT

8.OSDCK

9.EXPDT

10.EXPOE

11.EXPST

A30C5/C7

CMKM-P3X

PRODUCTION CODE

JA1402

JA1401

LF

AWX8847

AWX8848

AWX8849

AWX8860

AWX8861

AWX8862

AWX

1.NECK6

2.NECK8

3.AMUTE

4.SBMUTE

5.OSDRT

6.OSDCS

7.OSDDT

8.OSDCK

9.EXPDT

10.EXPOE

11.EXPST

A30C5/C7

CMKM-P3X

PRODUCTION CODE

SIDE B

# K COMPONENT ASSY

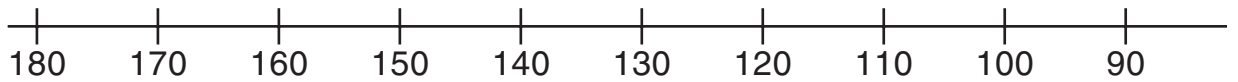
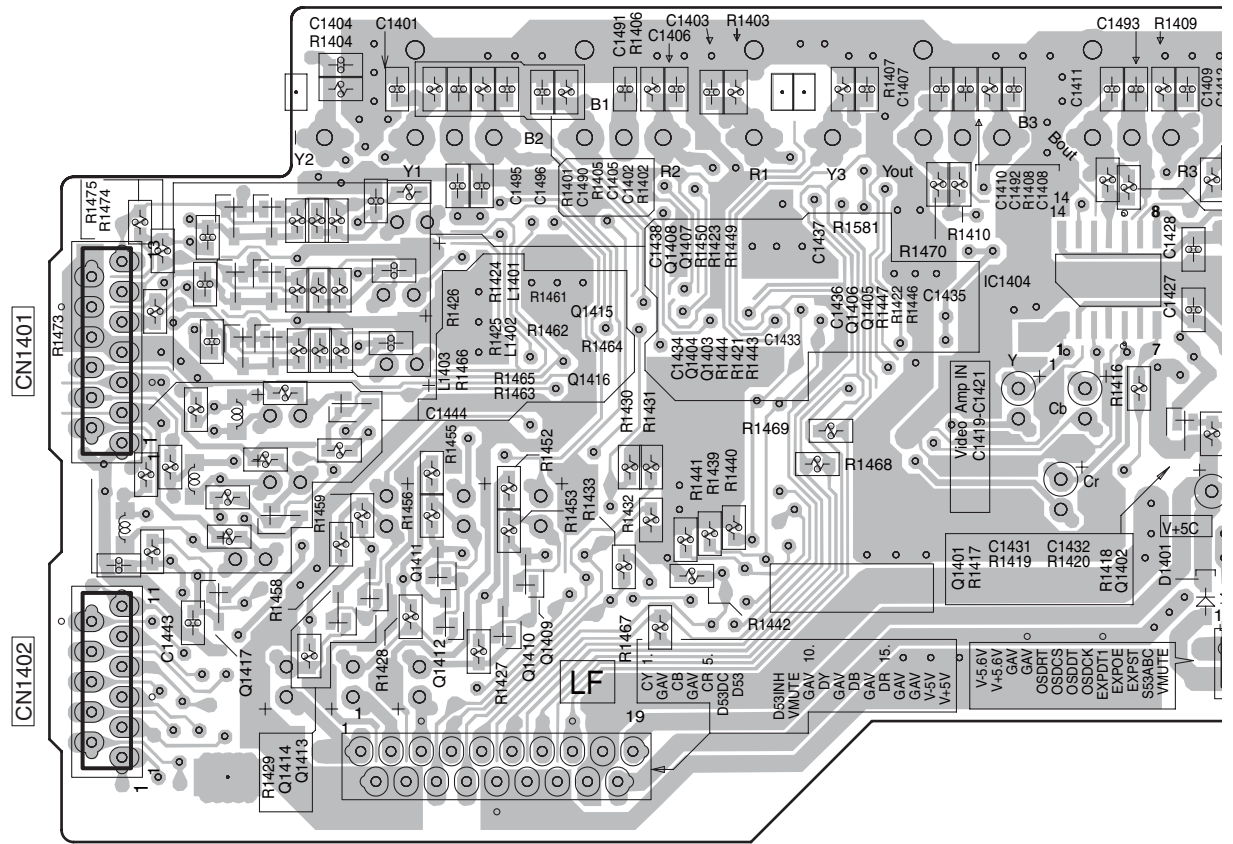

SIDE B

A

B

C

D

E

F

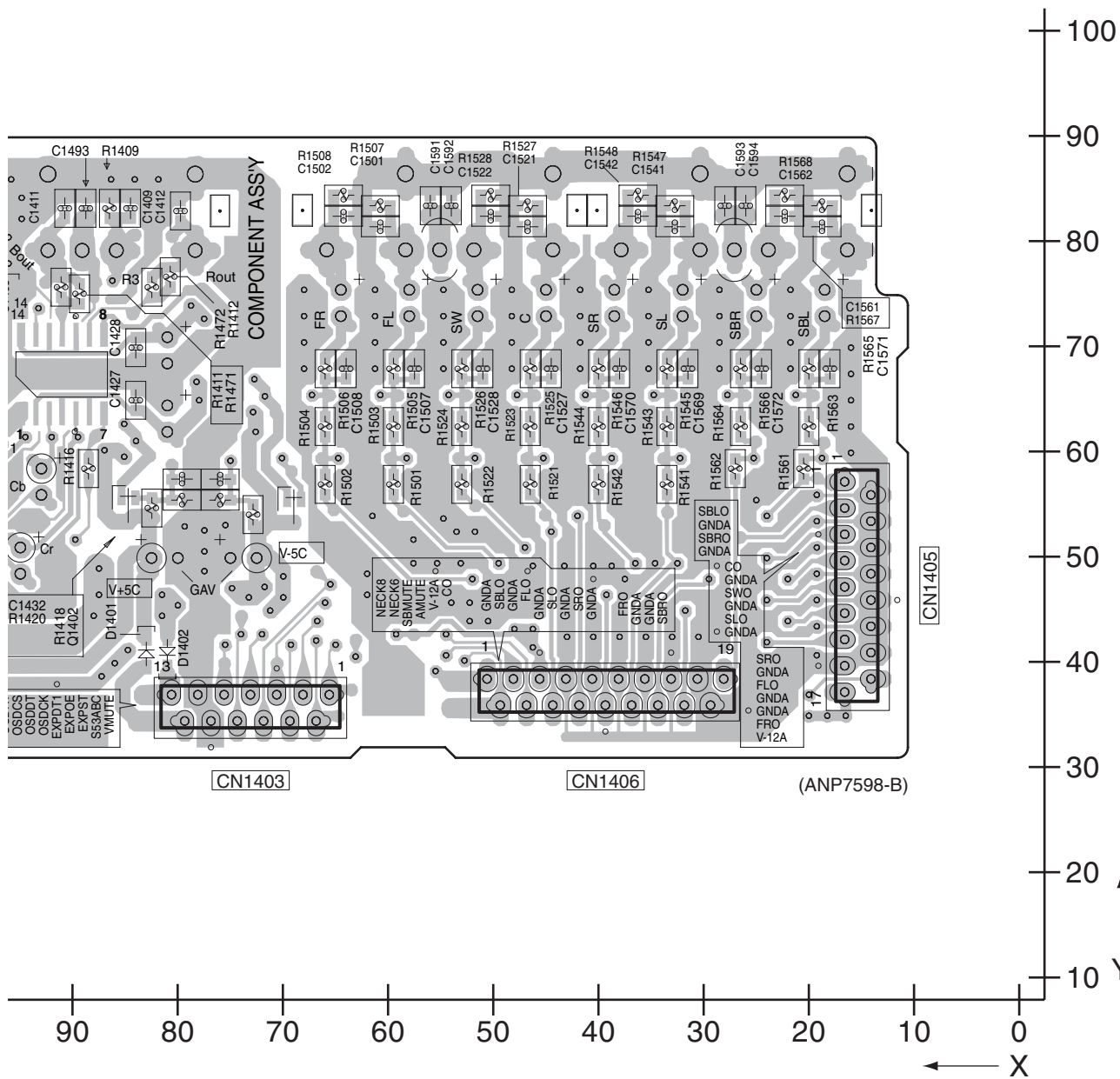



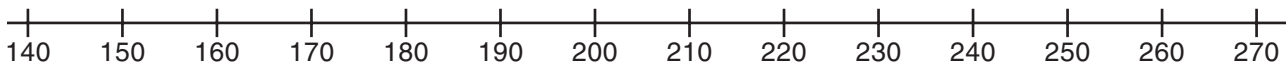
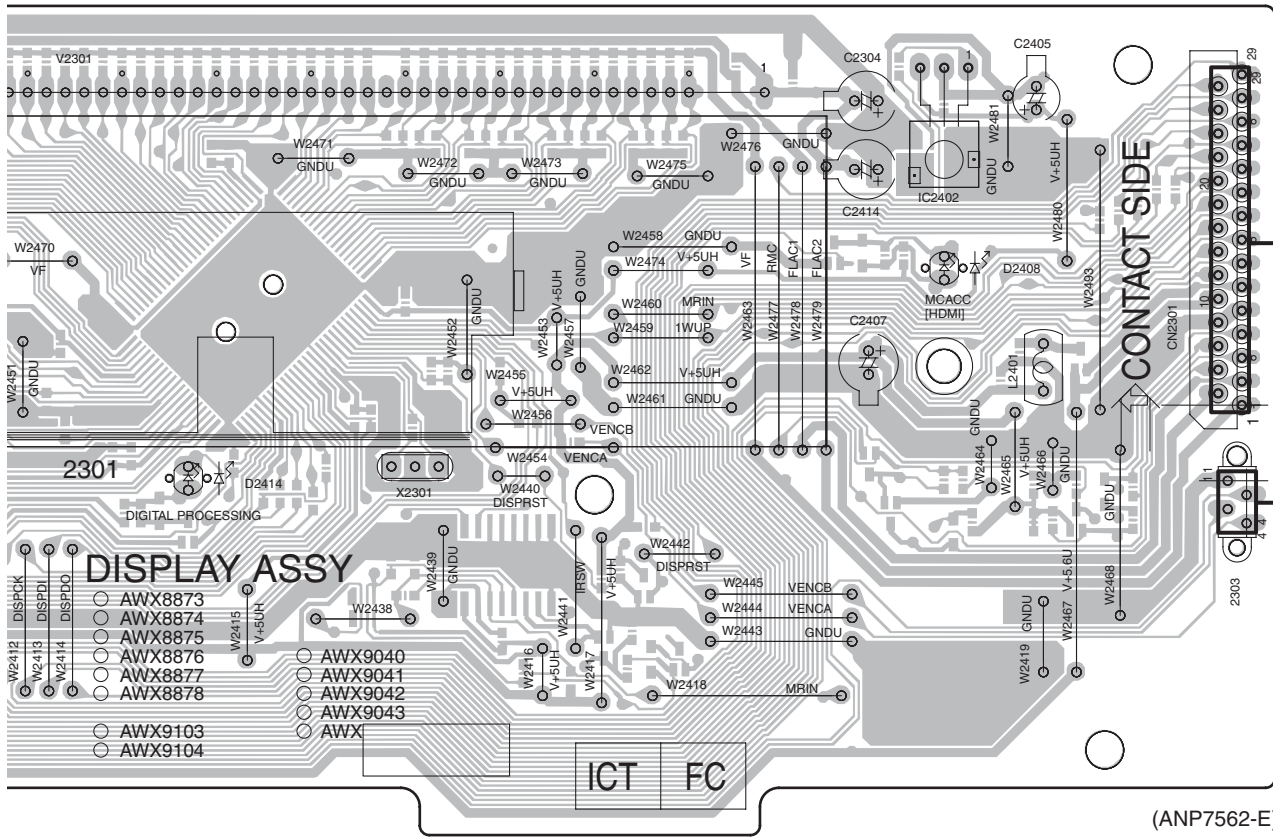

SIDE B

# DISPLAY ASSY

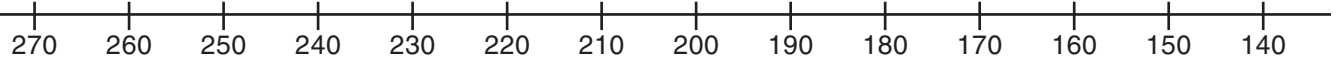
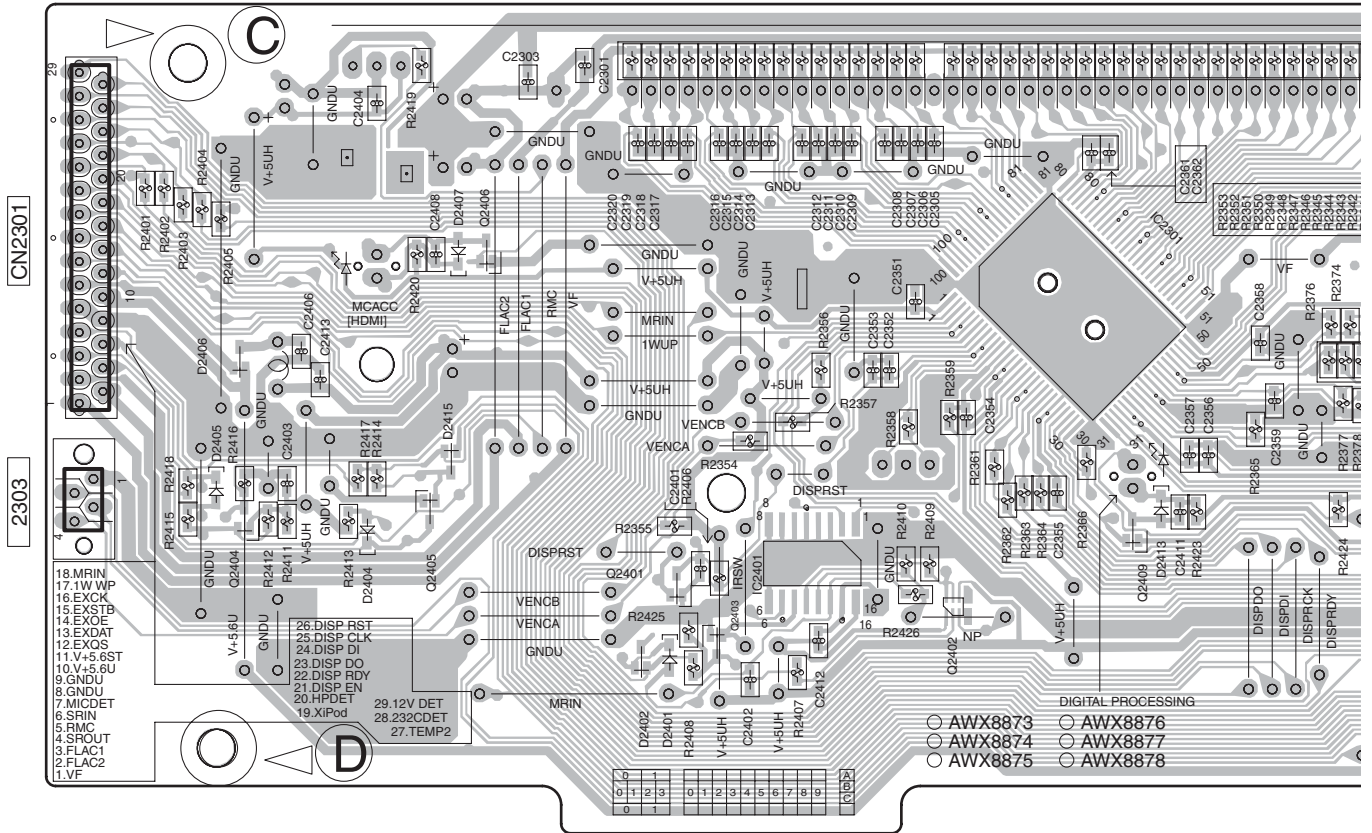

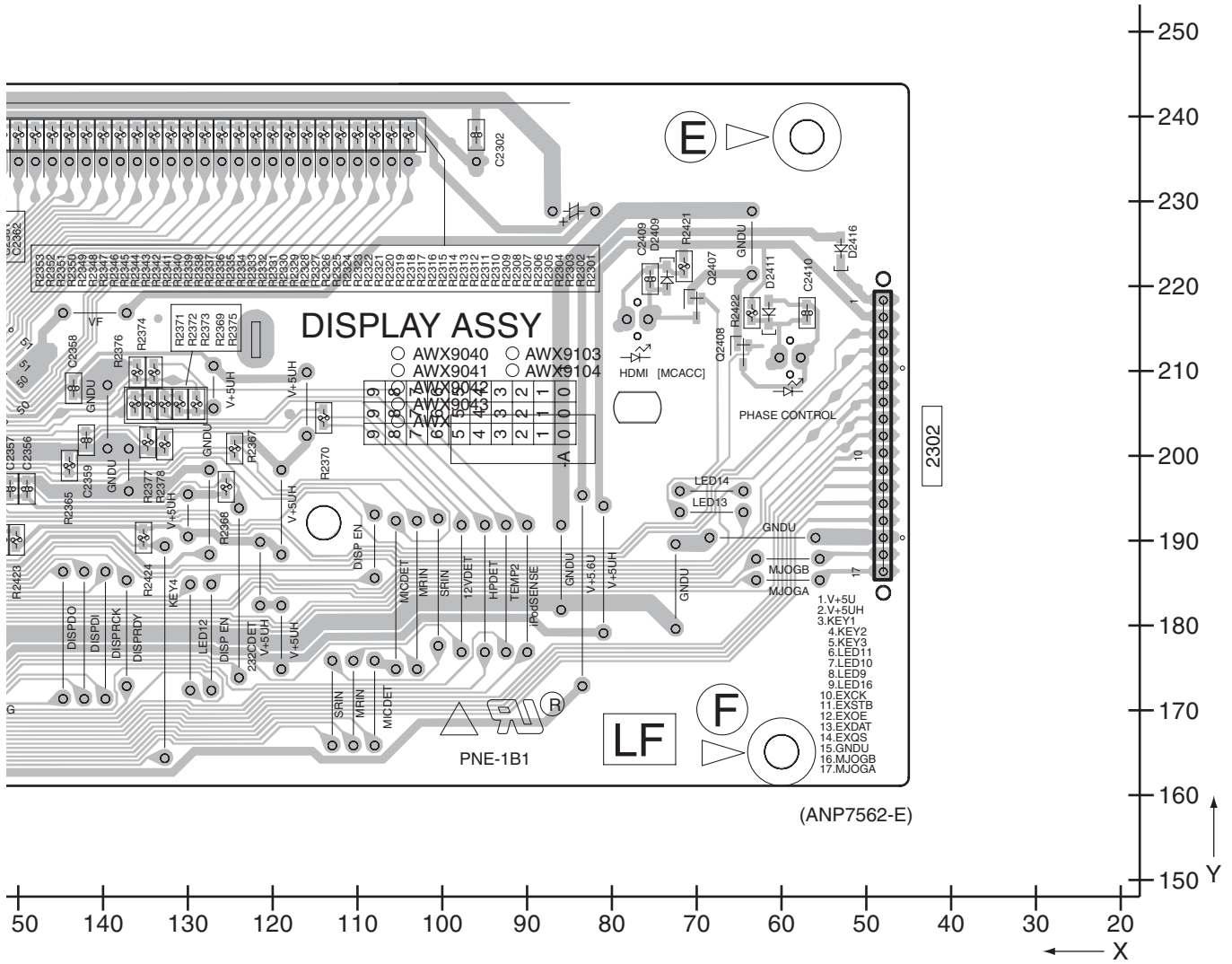

# 11.10 VOLUME ASSY

**SIDE A**

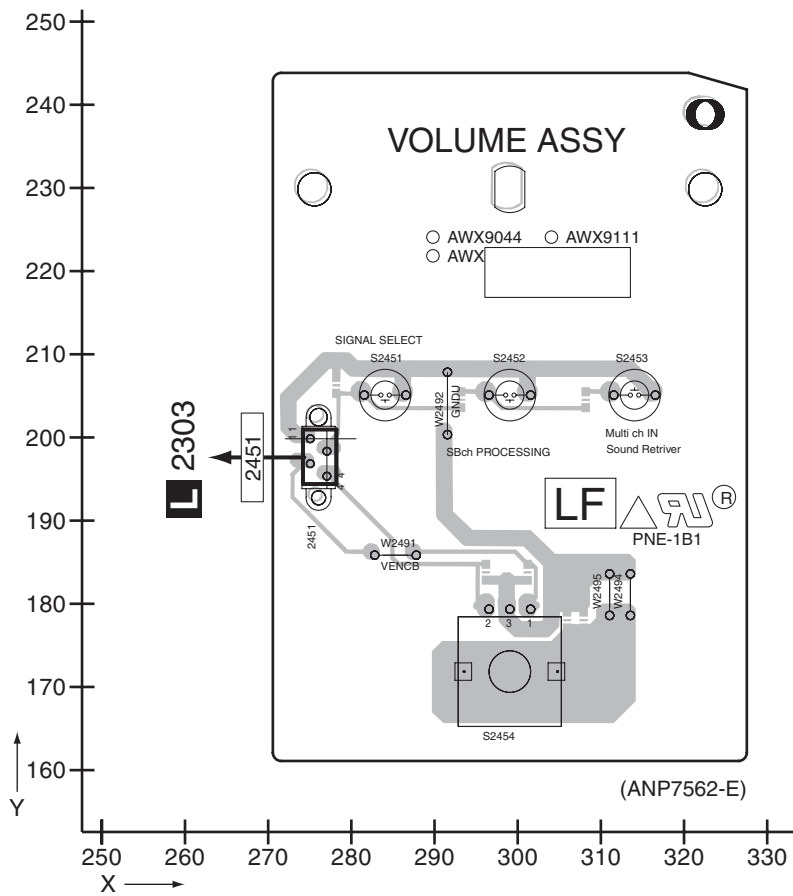

**SIDE A**

**M** VOLUME ASSY

**SIDE B**

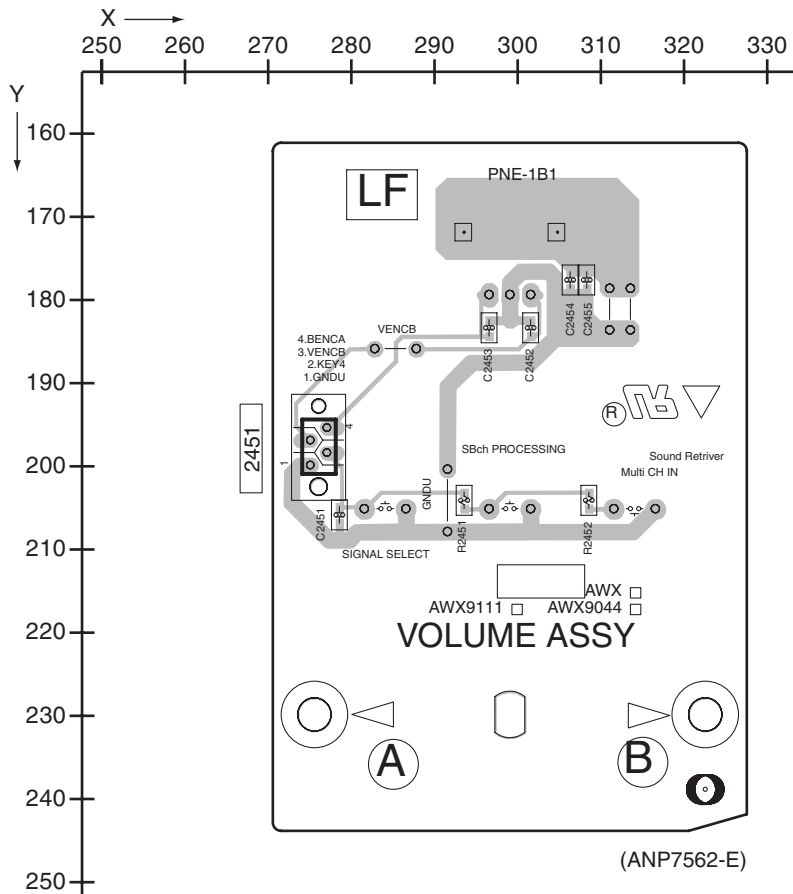

**SIDE B**

**M** VOLUME ASSY

**M**

**M**

5 6 7 8

# 11.11 HEADPHONE ASSY

**SIDE A**

**SIDE A**

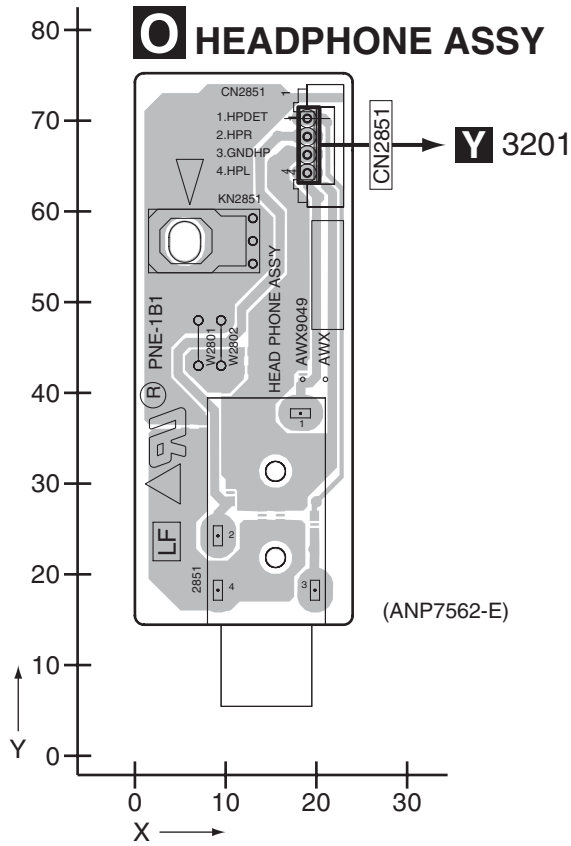

**SIDE B**

**SIDE B**

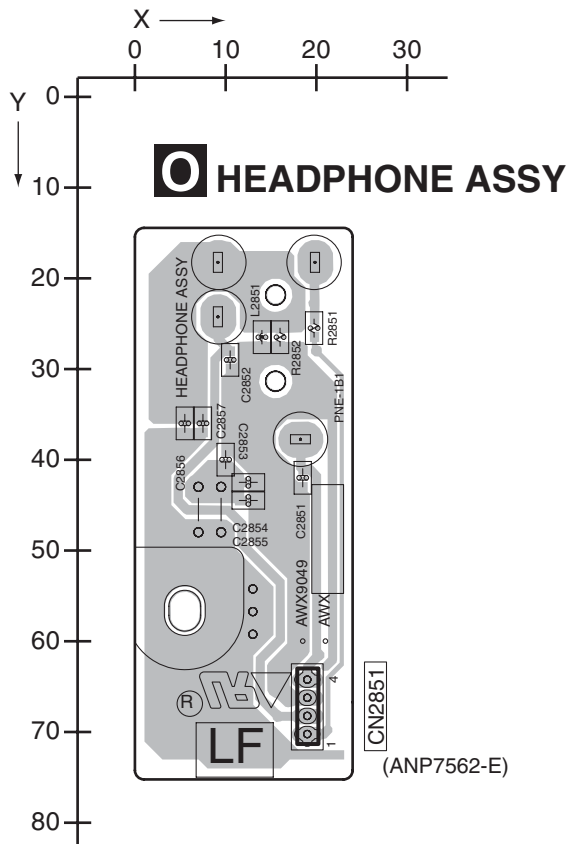

# 11.12 MULTI JOG ASSY

**SIDE A**

## N MULTI JOG ASSY

A  
B  
C  
D  
E  
F

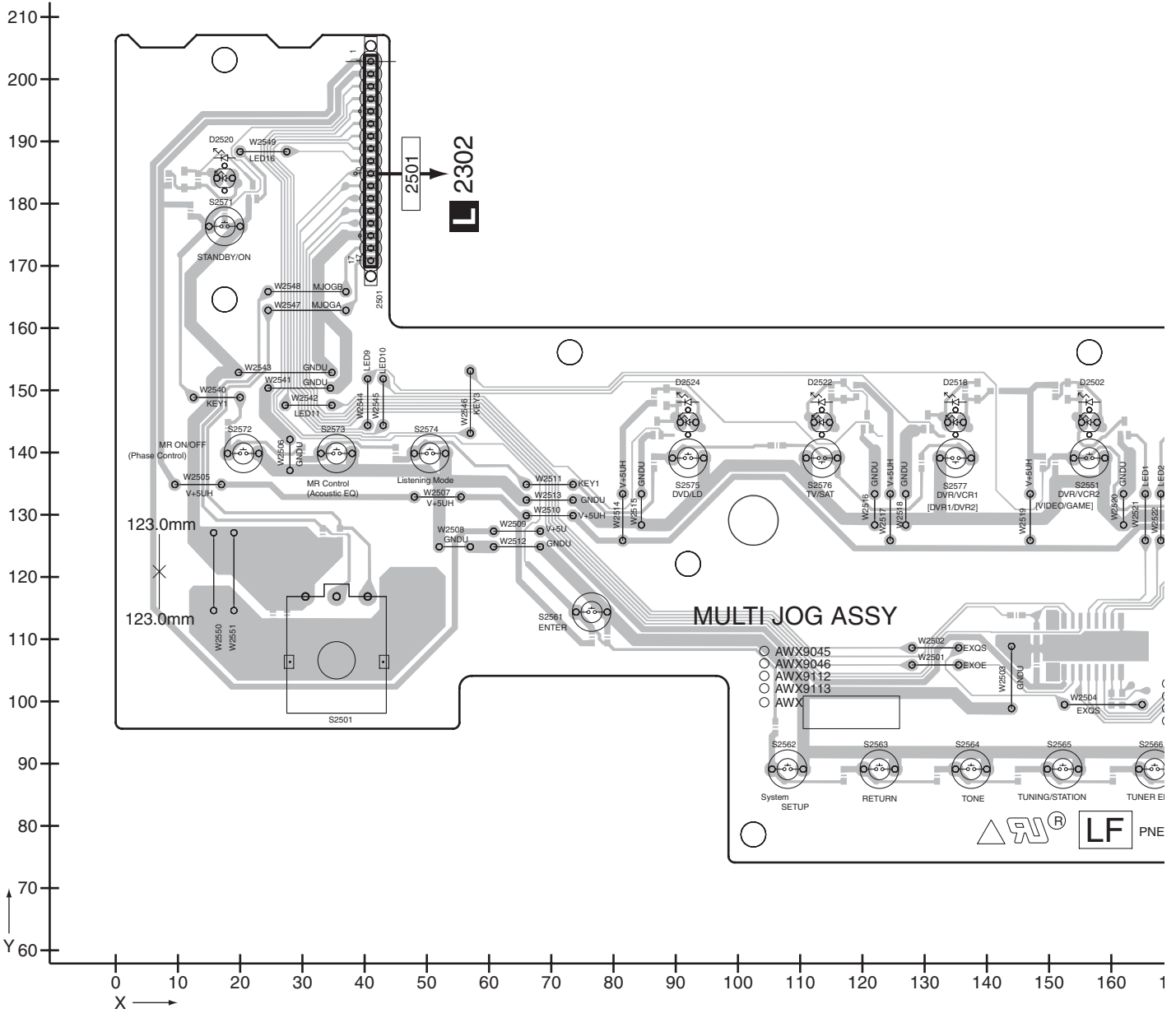

**N**

180

VSX-LX50

1

2

3

4



SIDE B

A

B

# N MULTI JOG ASSY

C

D

E

F

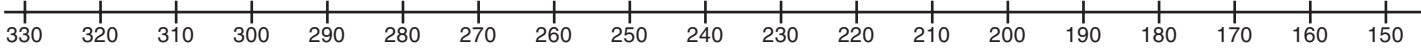
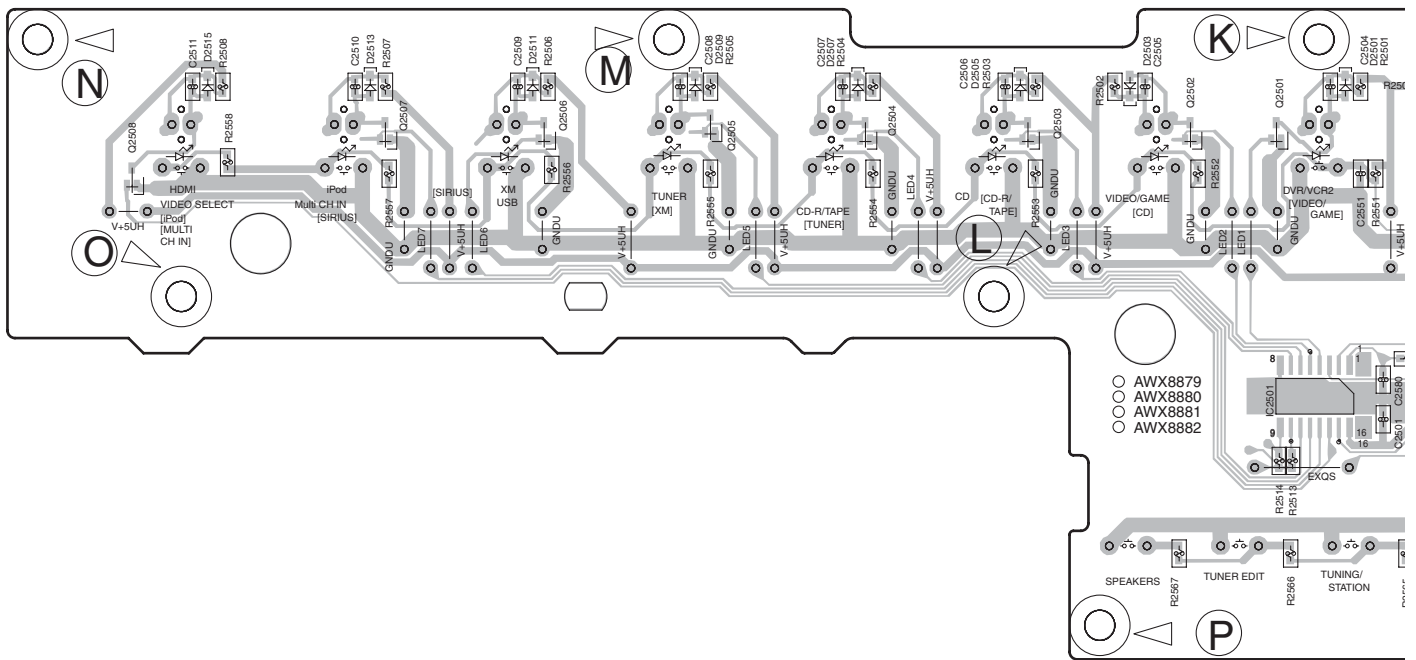

# N

SIDE B

A

B

C

D

E

F

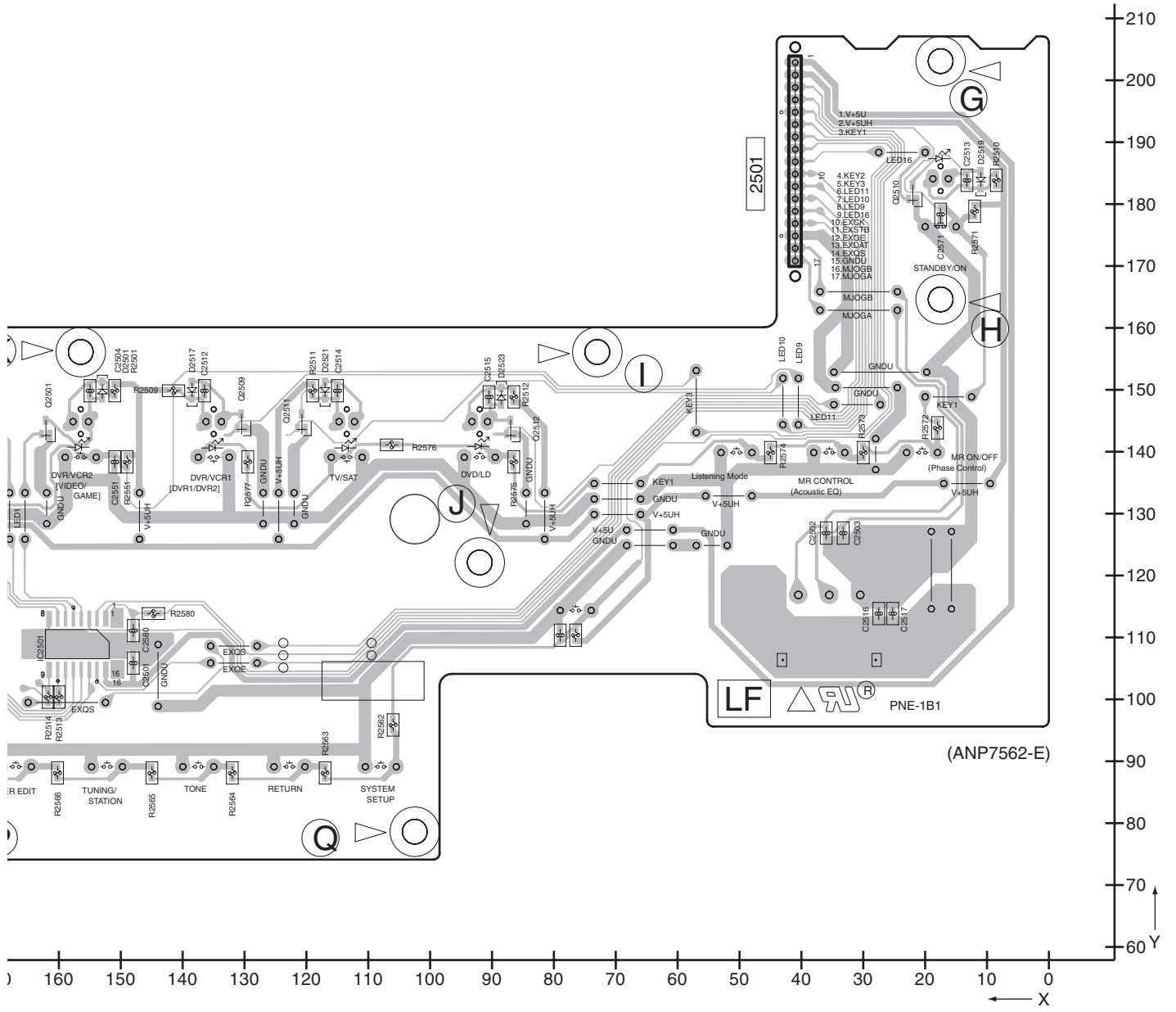

# 11.13 FRONT-IN ASSY

**SIDE A**

## **P** FRONT-IN ASSY

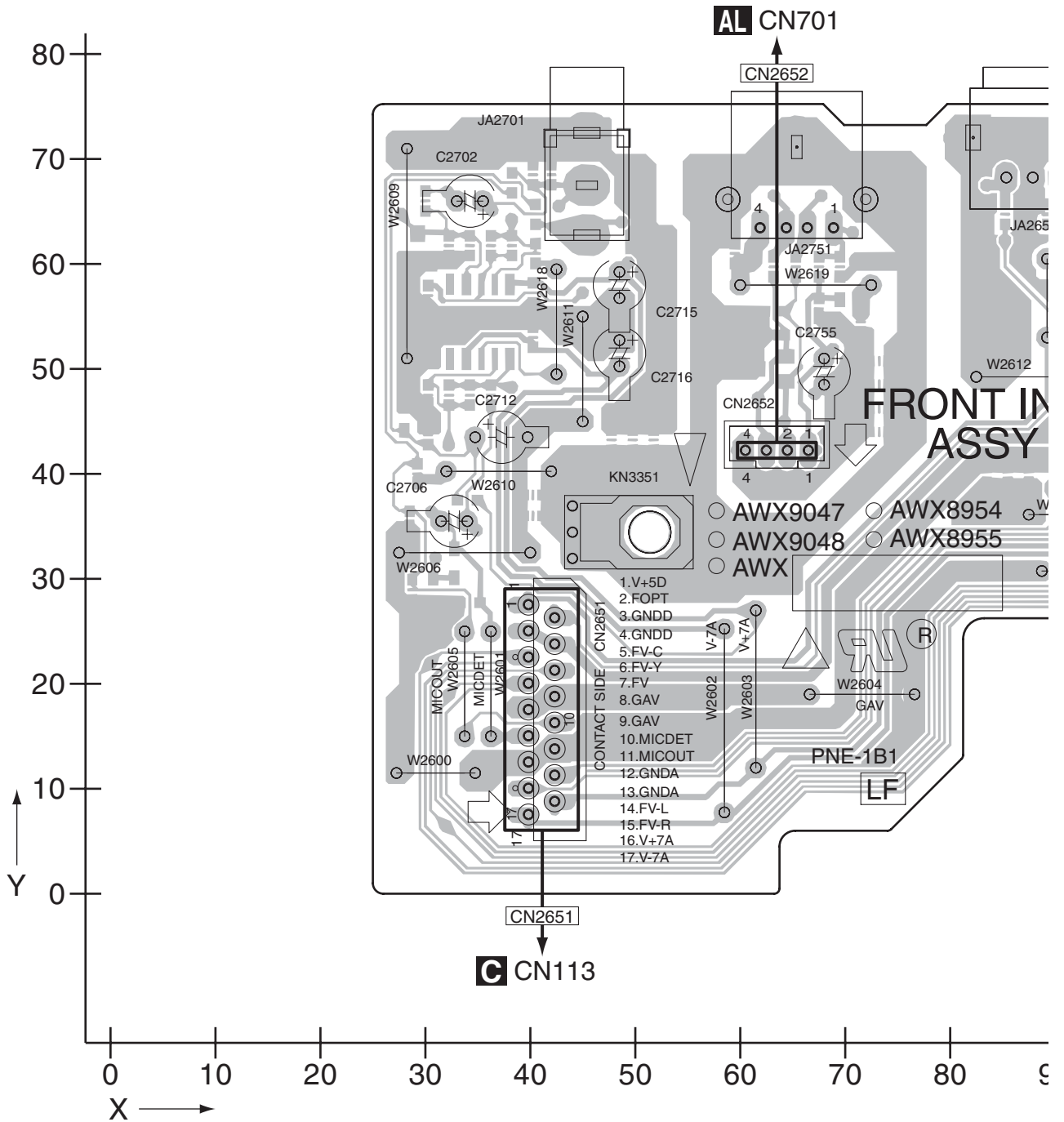

**P**

SIDE A

A

B

C

D

E

F

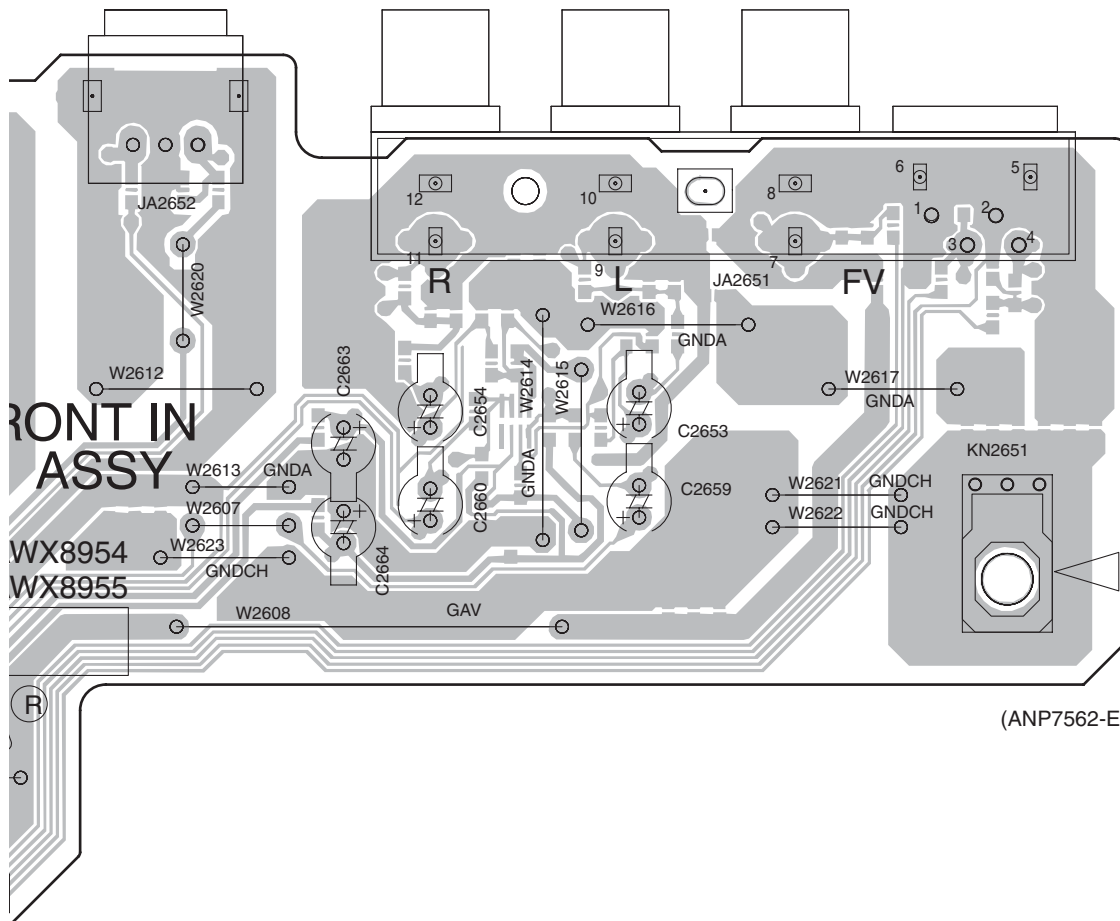

(ANP7562-E)

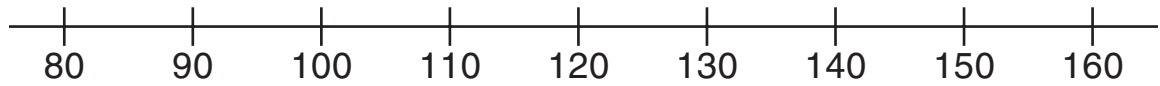



SIDE B

A

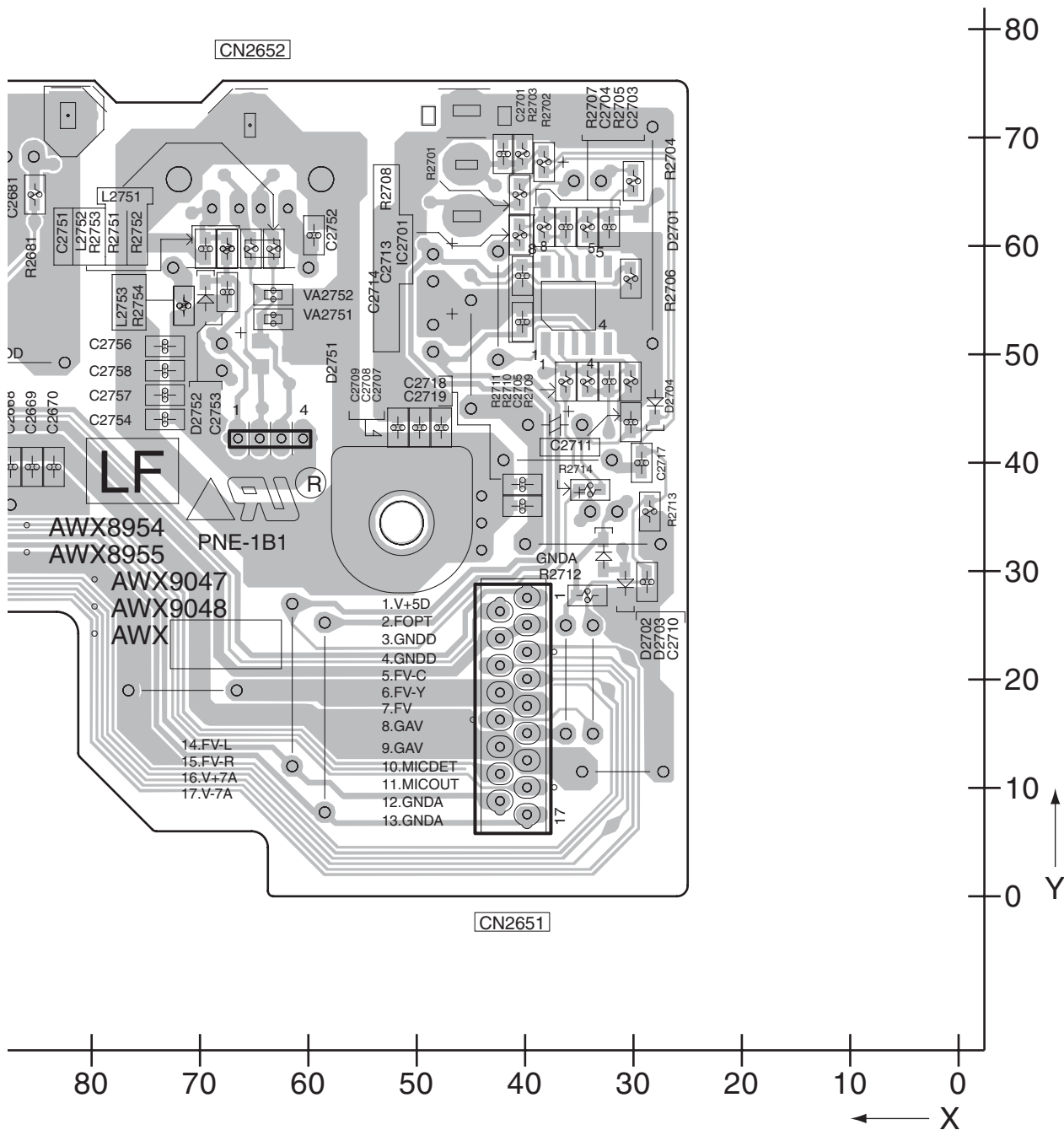

B

C

D

E

F

11.14 PRIMARY ASSY

SIDE A

Q PRIMARY ASSY

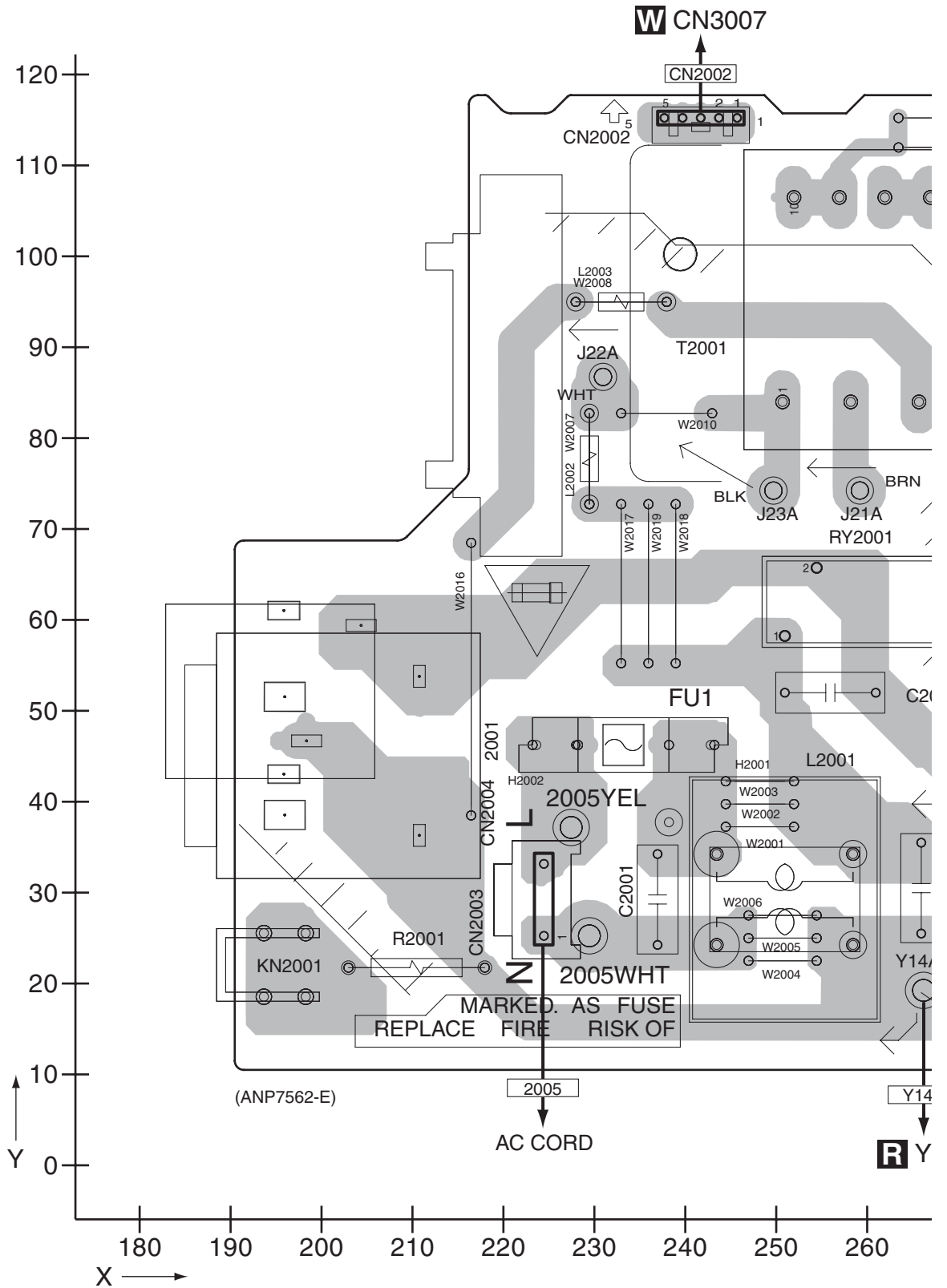

Q

**SIDE A**

A

B

C

D

E

F

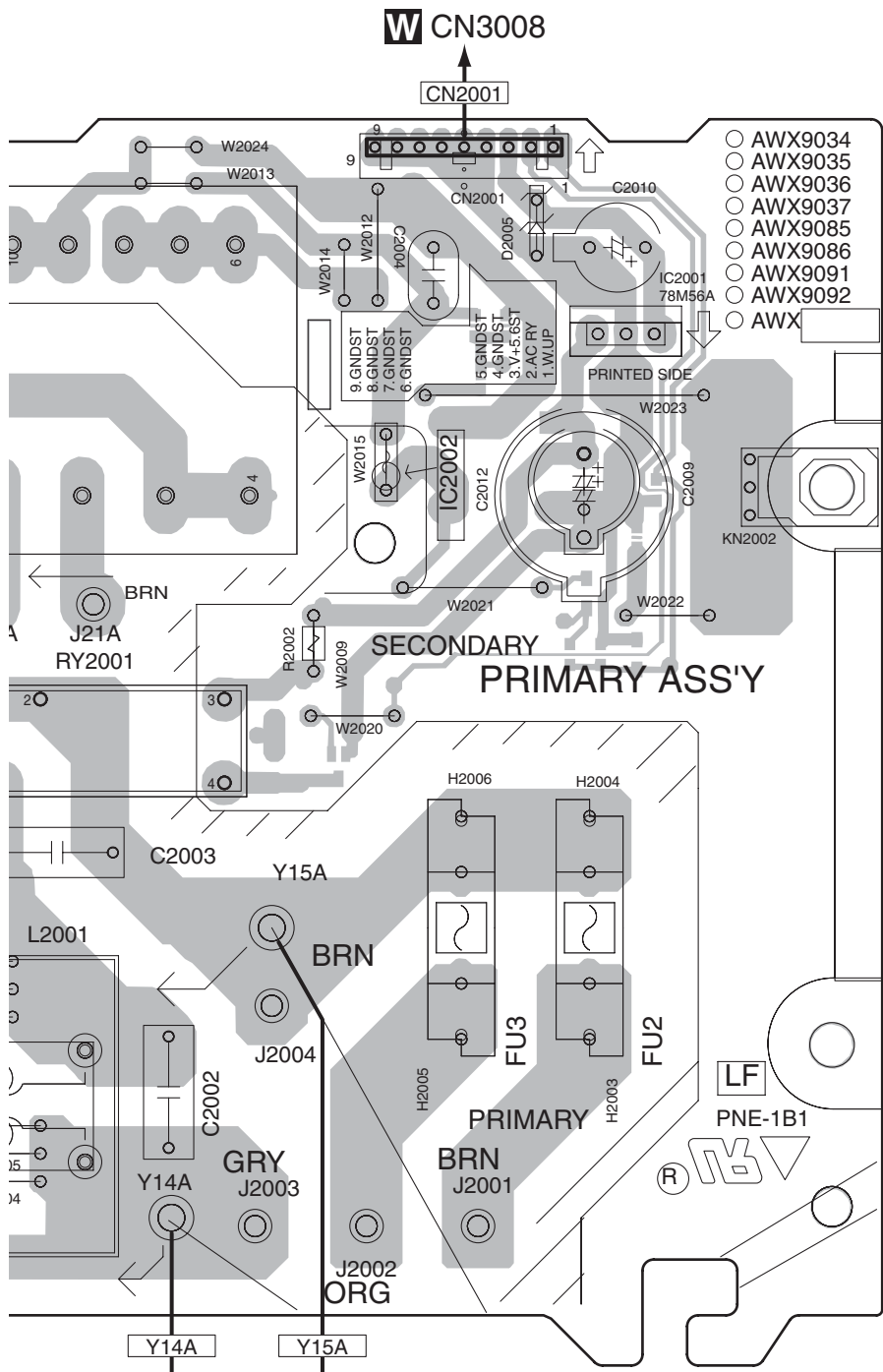

**R** Y14B **R** Y15B

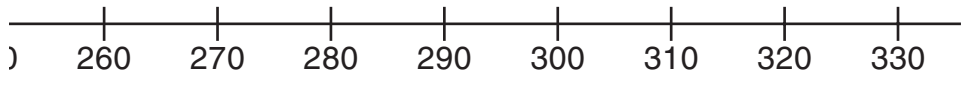

SIDE B

# Q PRIMARY ASSY

A

B

C

D

E

F

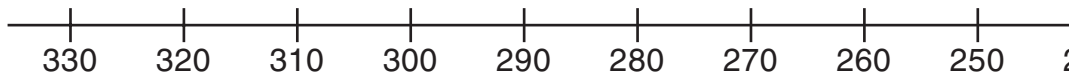
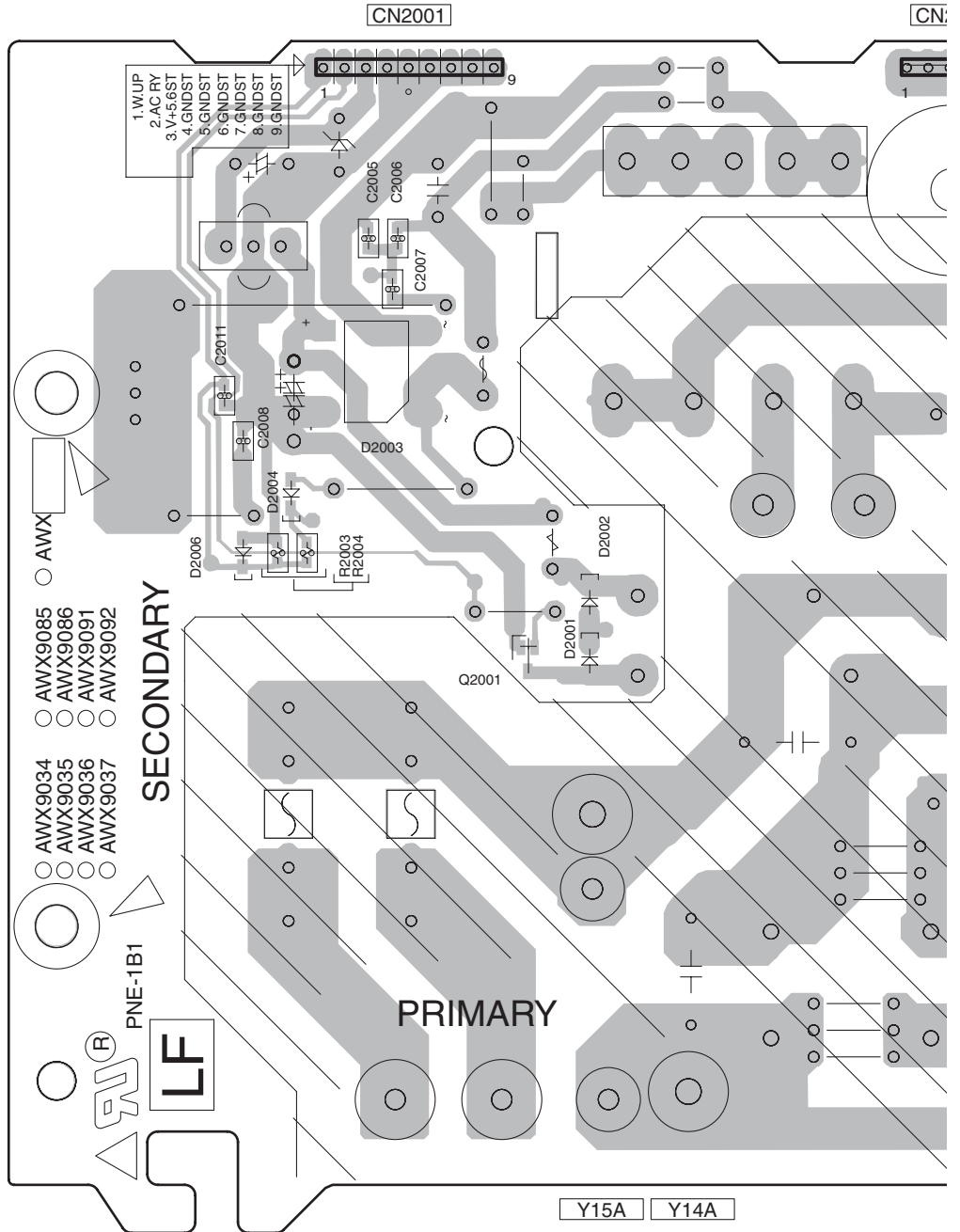

**SIDE B**

A  
B  
C  
D  
E  
F

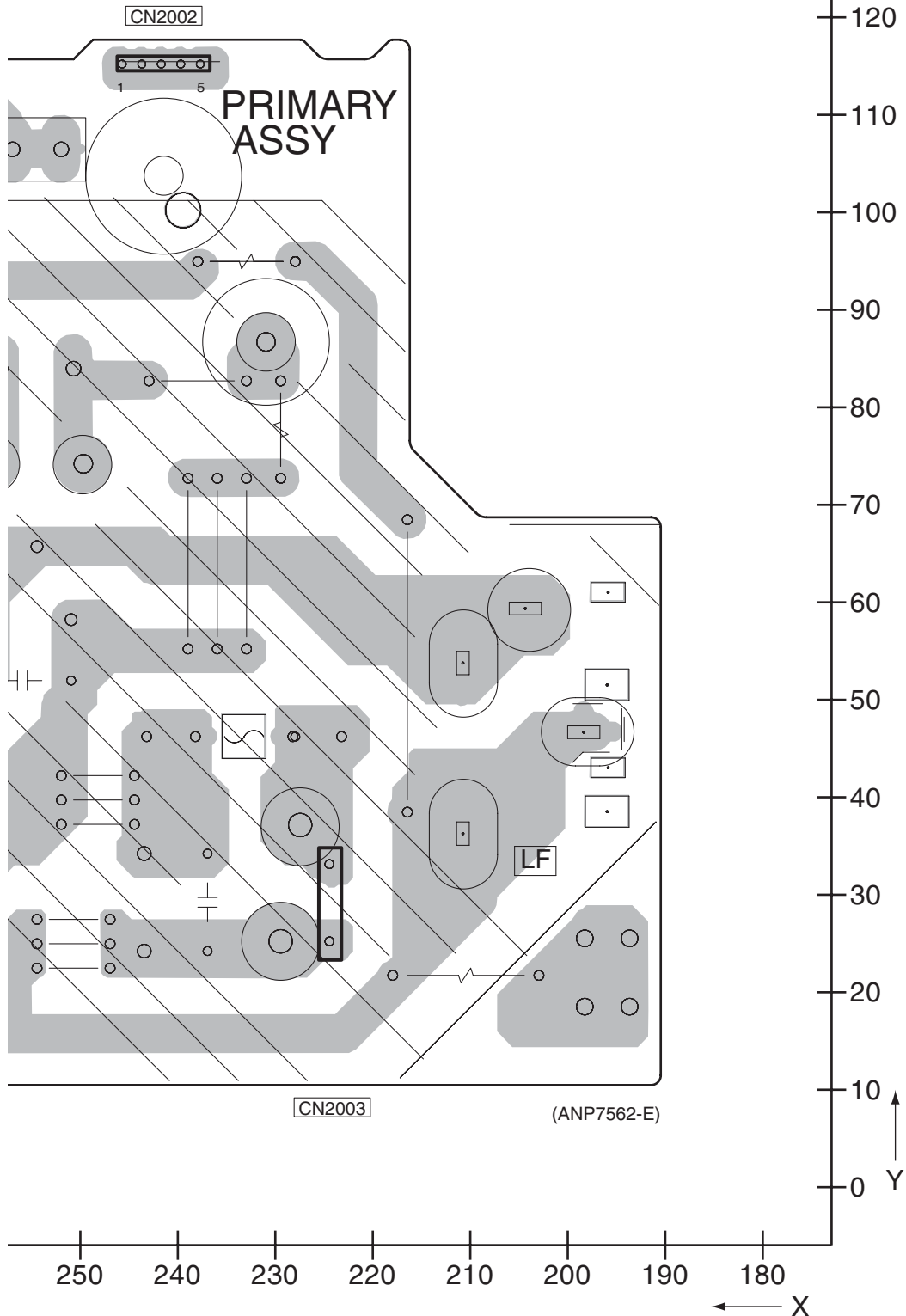

# 11.15 TRANS 1 ASSY

**SIDE A**

**SIDE A**

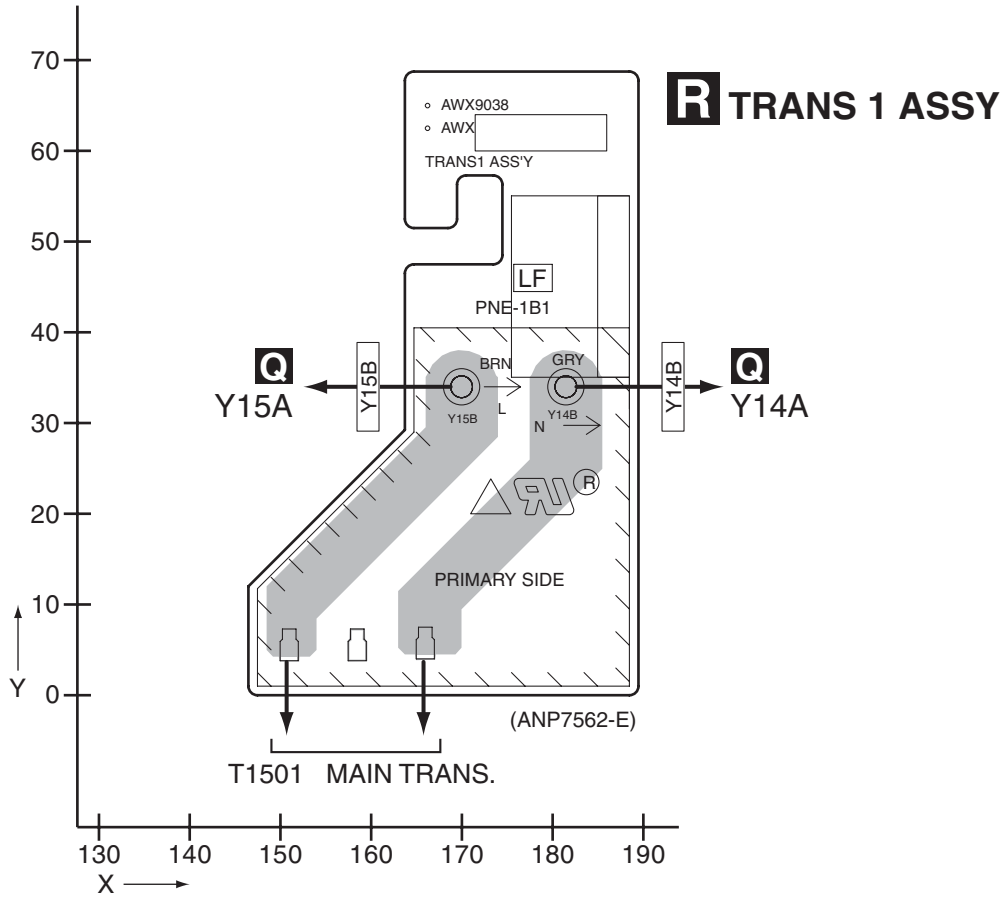

**SIDE B**

**SIDE B**

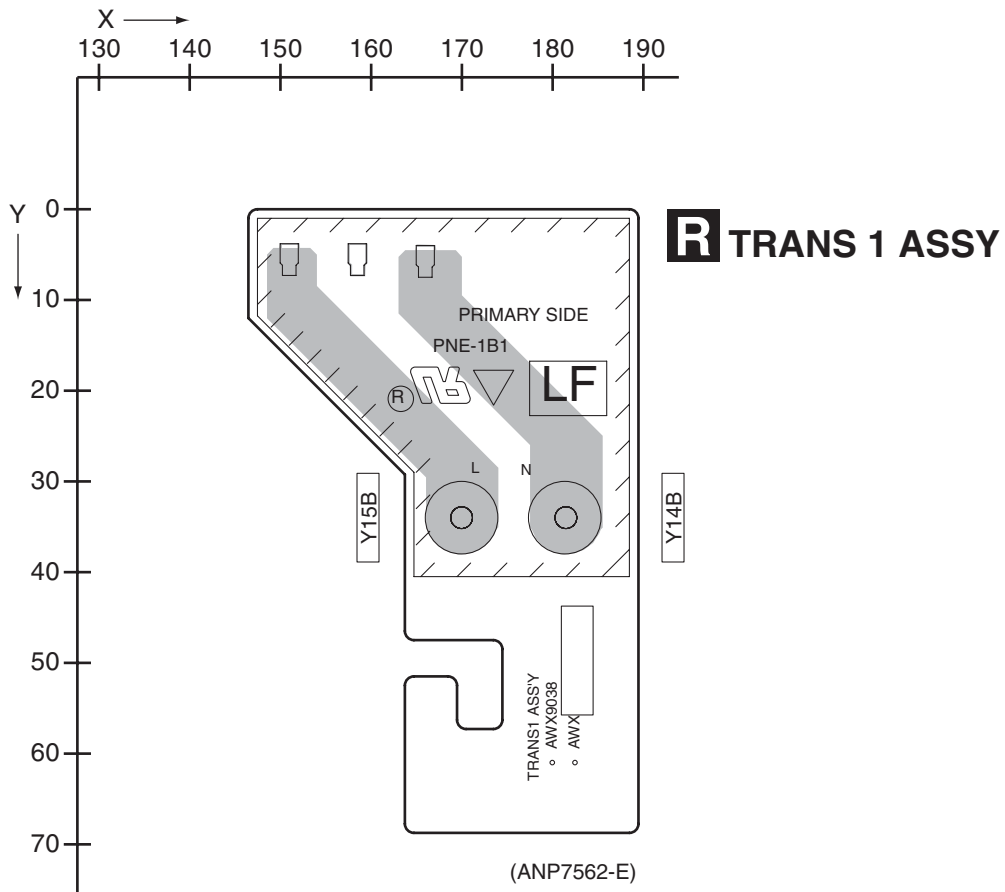

**R**

**R**

# 11.16 TRANS 2-1 ASSY

**SIDE A**

**SIDE A**

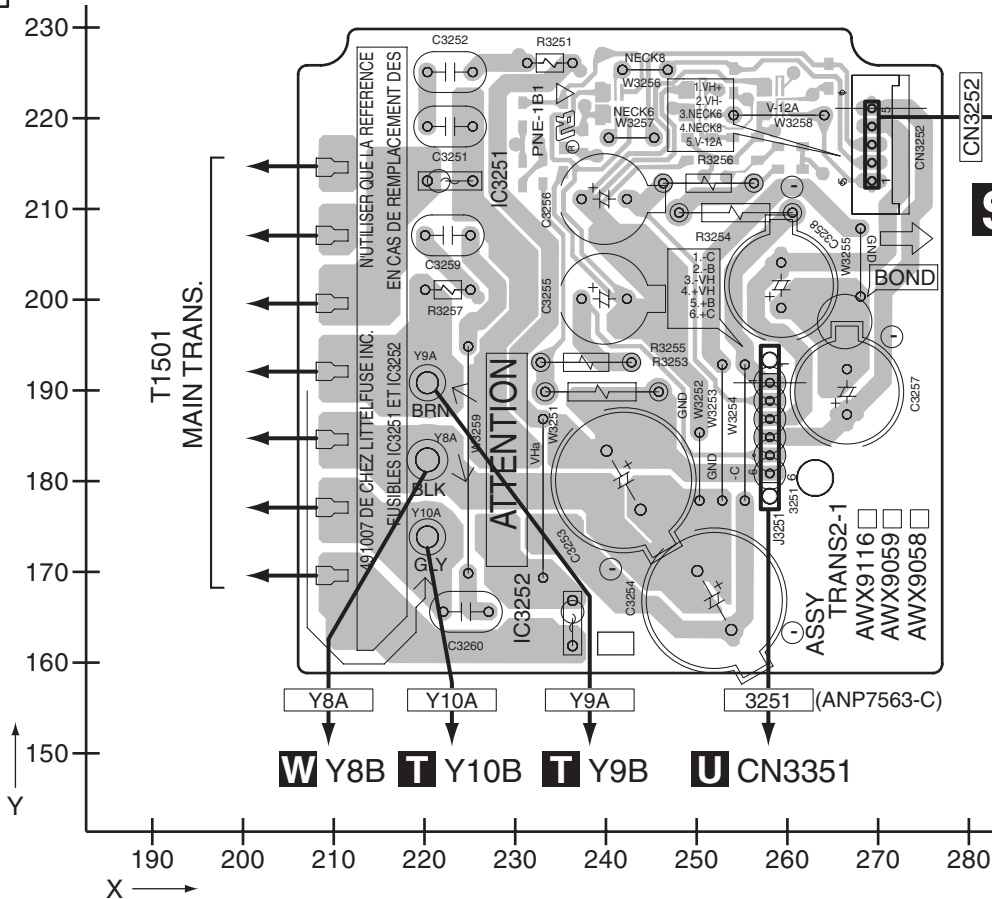

**S** TRANS 2-1 ASSY

**SIDE B**

**SIDE B**

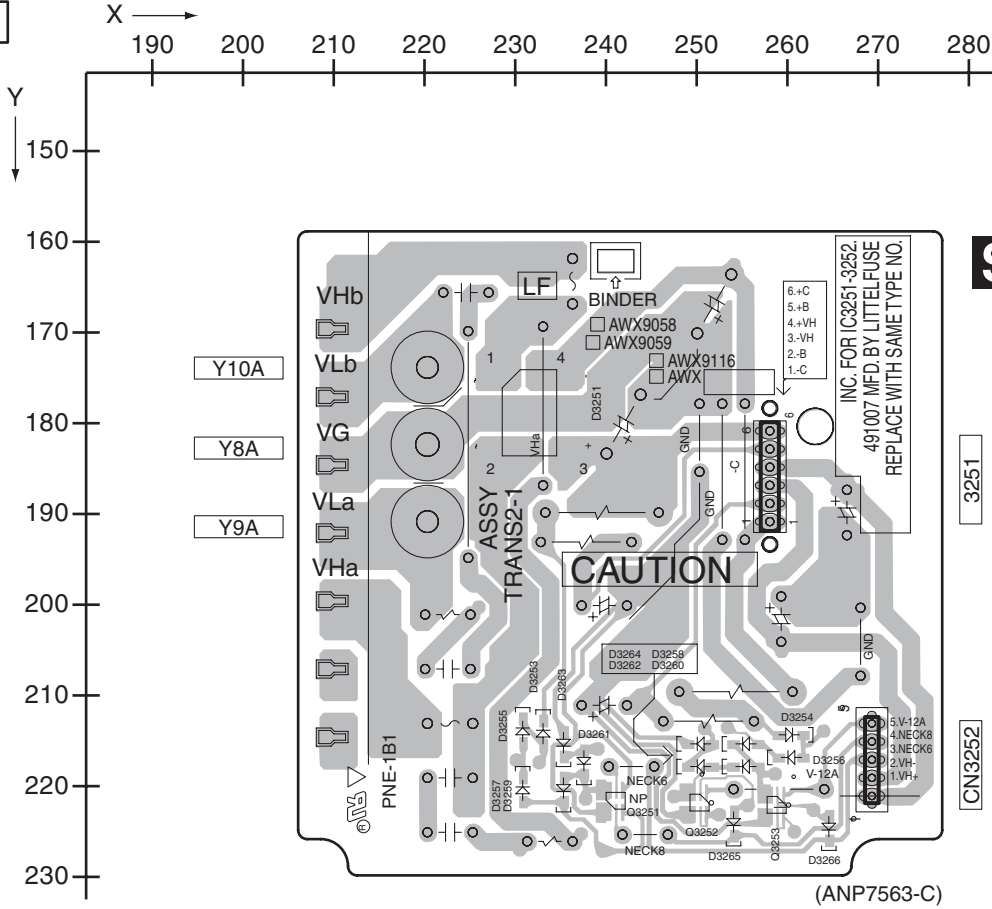

**S** TRANS 2-1 ASSY

**S**

**S**

VSX-LX50

# 11.17 DIODE 1 and VH TR ASSYS

**SIDE A**

**SIDE B**

A

B

C

D

E

F

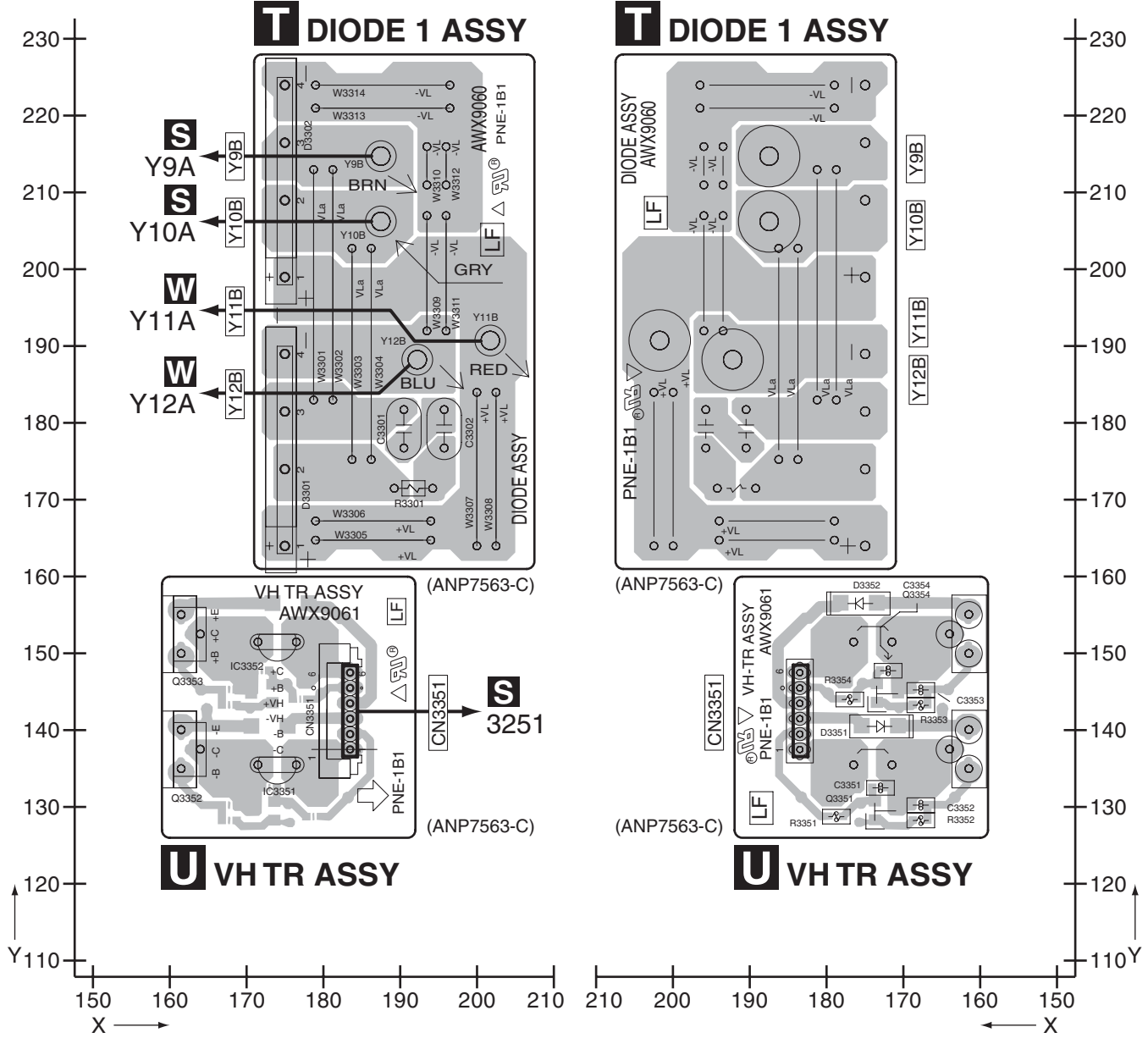

**T U**

**T U**

11.18 BRIDGE 1 ASSY

SIDE A

SIDE A

V BRIDGE 1 ASSY

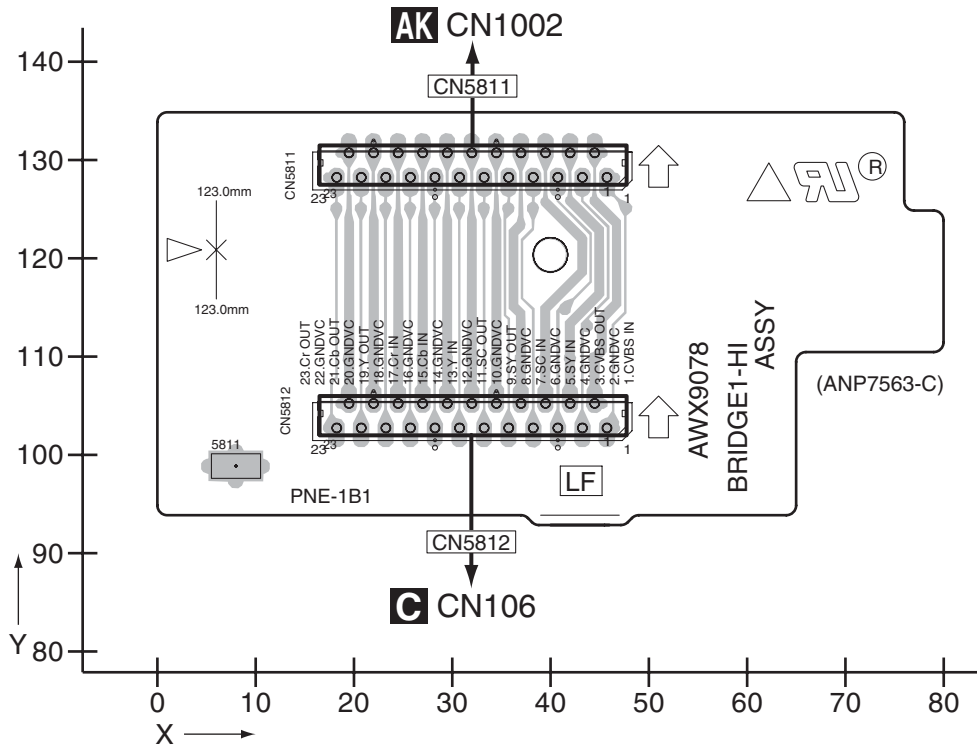

SIDE B

SIDE B

V BRIDGE 1 ASSY

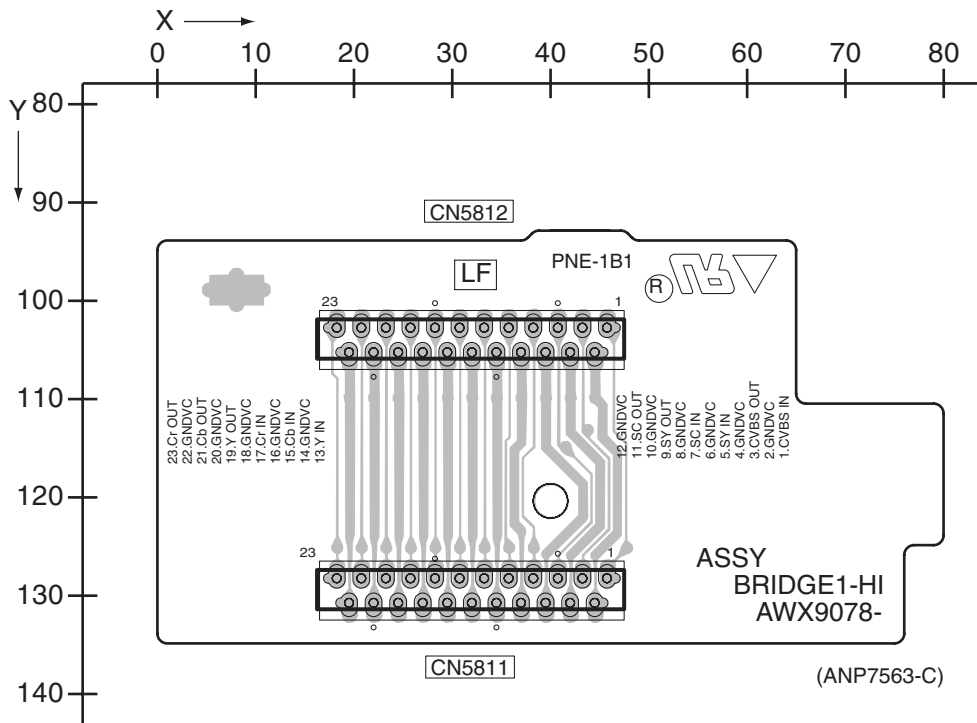

V

V

11.19 PS/SP ASSY

SIDE A

W PS/SP ASSY

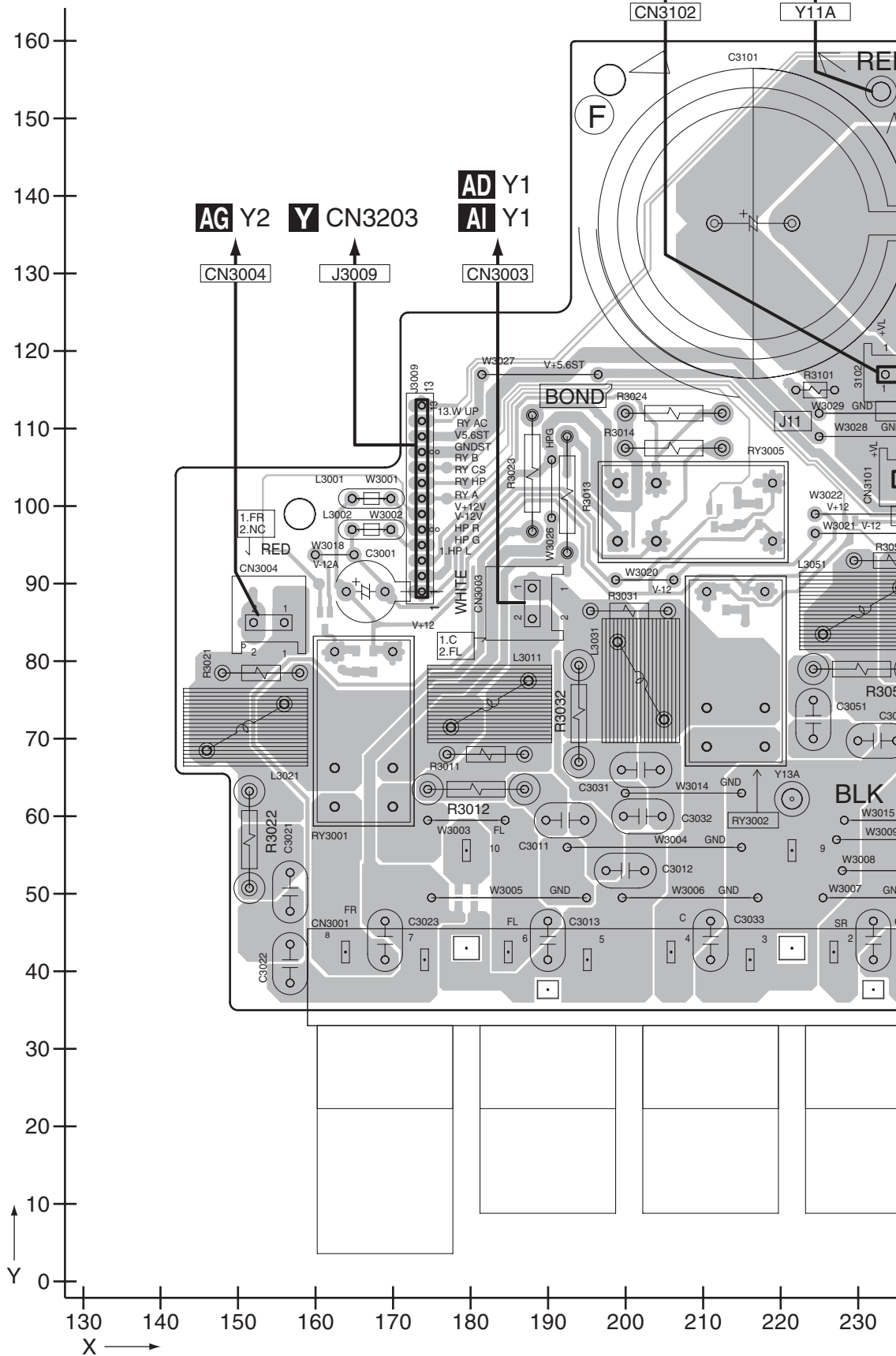



**SIDE B**

**W PS/SP ASSY**

Y12A Y8B Y11A

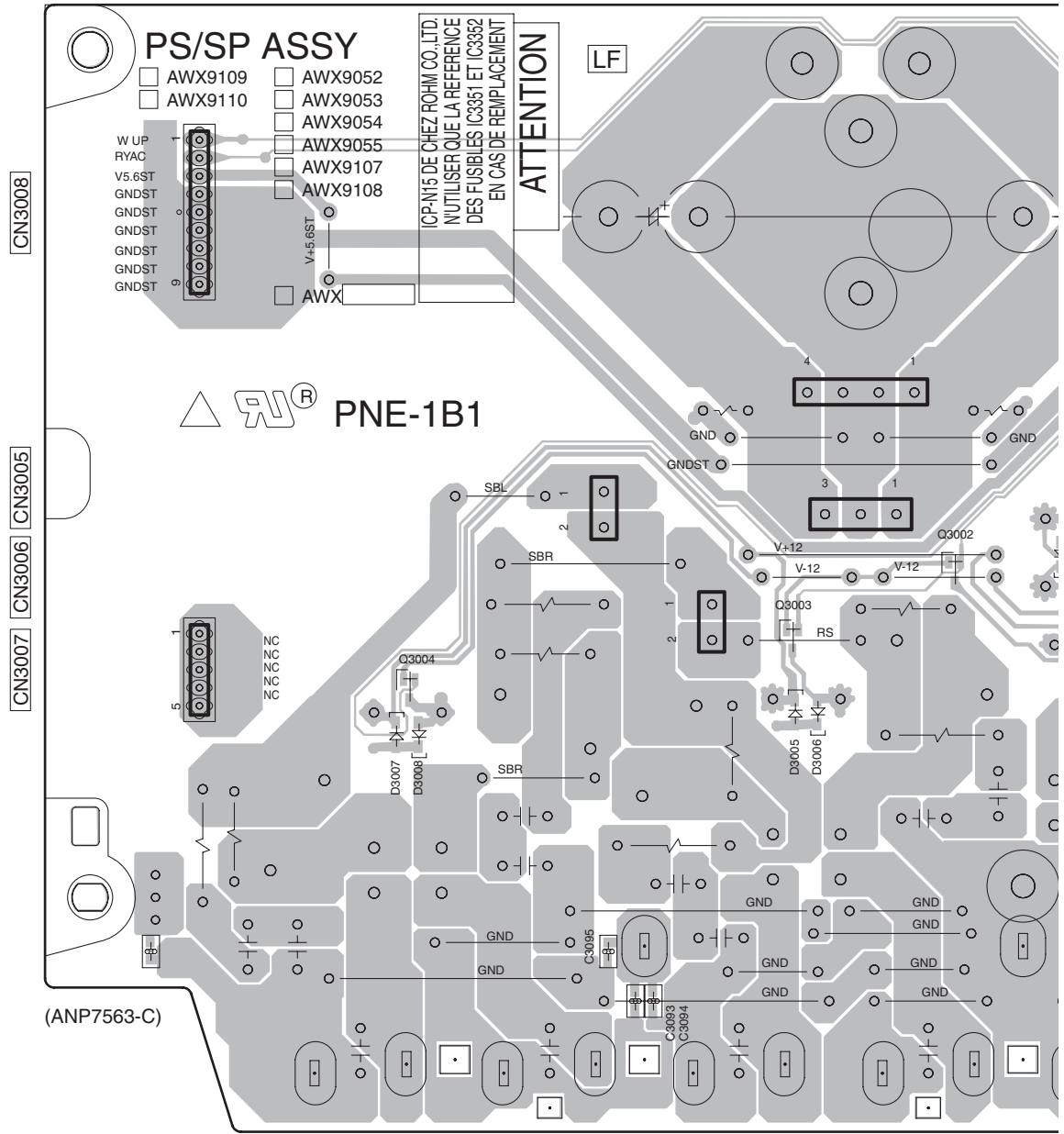

CN3102 CN3101

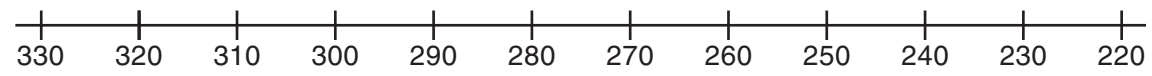

VSX-LX50



SIDE B

A

B

C

D

E

F

Y11A

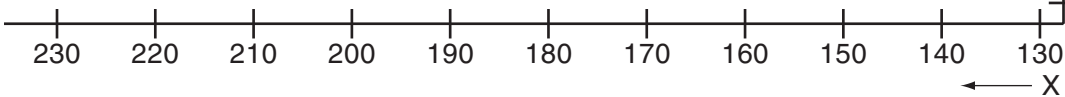
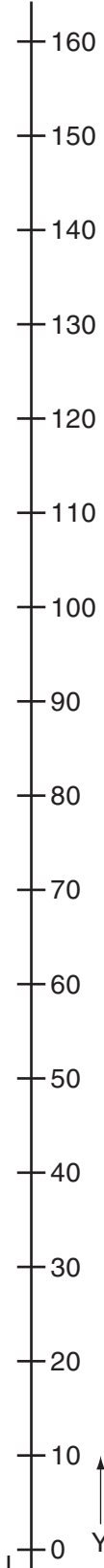
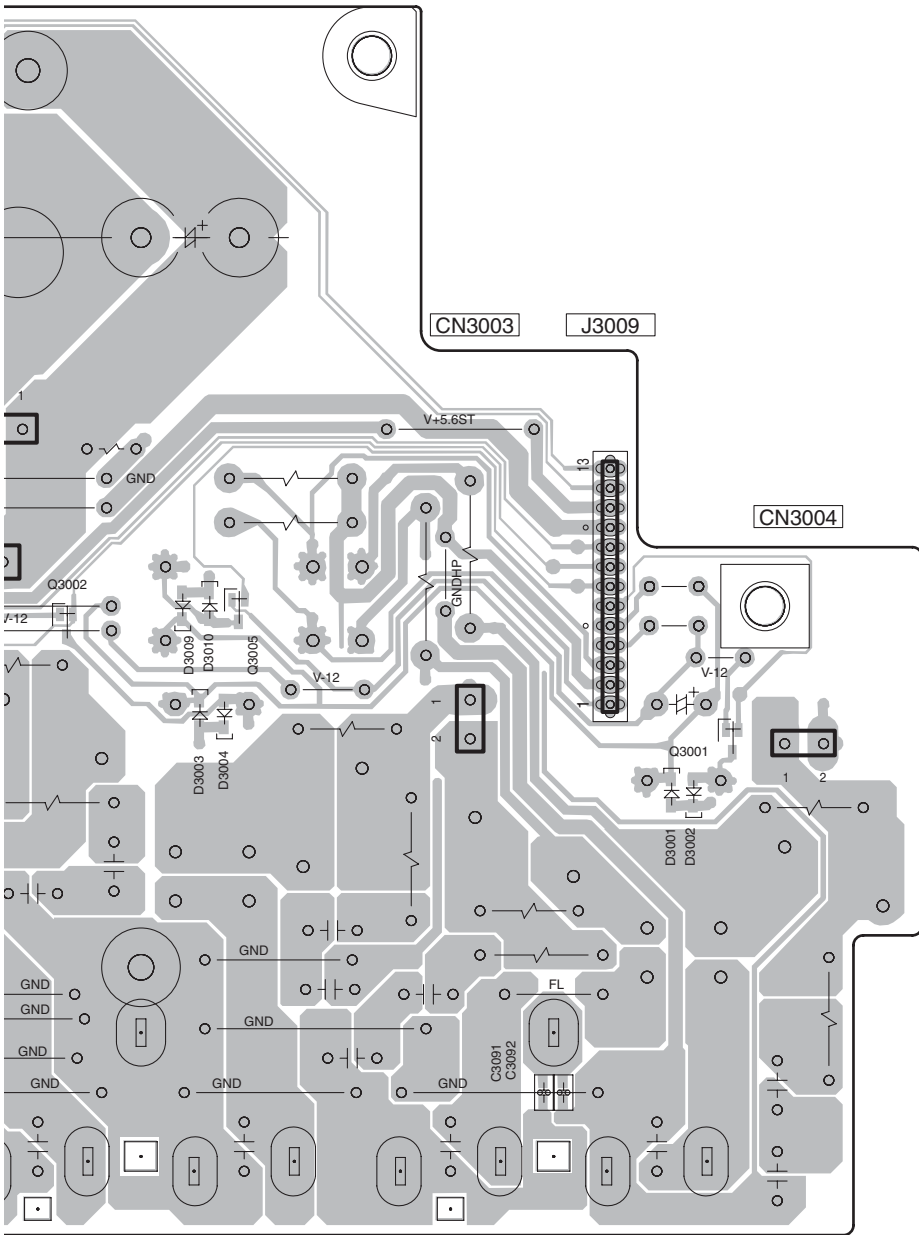

VSX-LX50



# 11.20 TRANS 2-2 ASSY

**SIDE A**

**SIDE A**

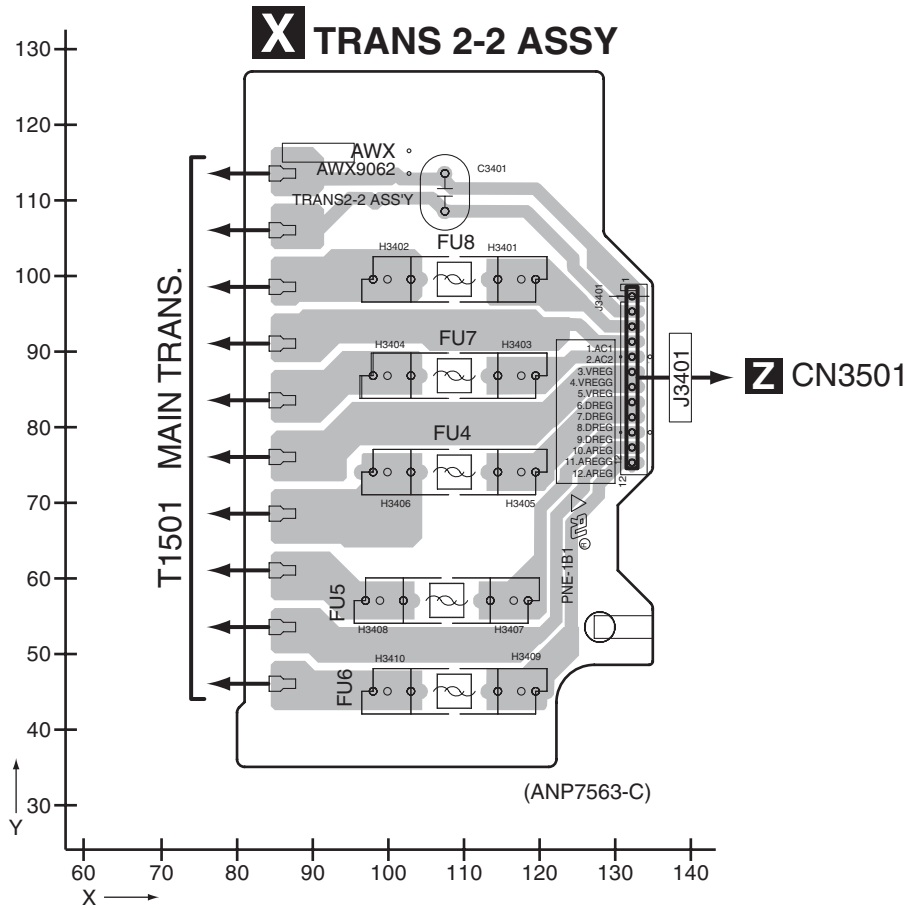

**SIDE B**

**SIDE B**

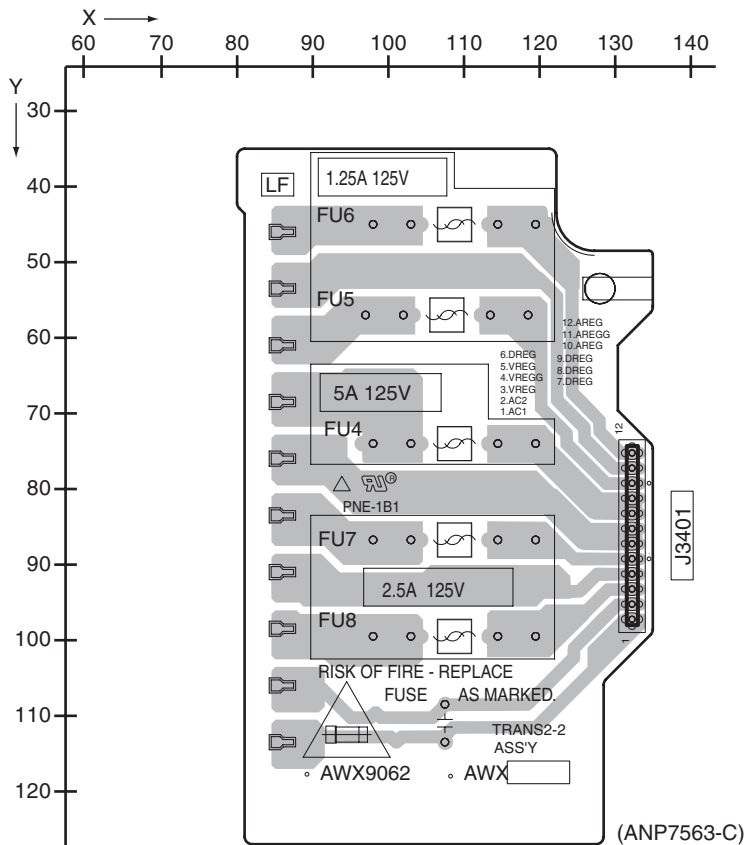

200

**X TRANS 2-2 ASSY**



VSX-LX50

11.21 POSI 1-L, POSI 2-L and POSI 1-R ASSYS

SIDE A

SIDE A

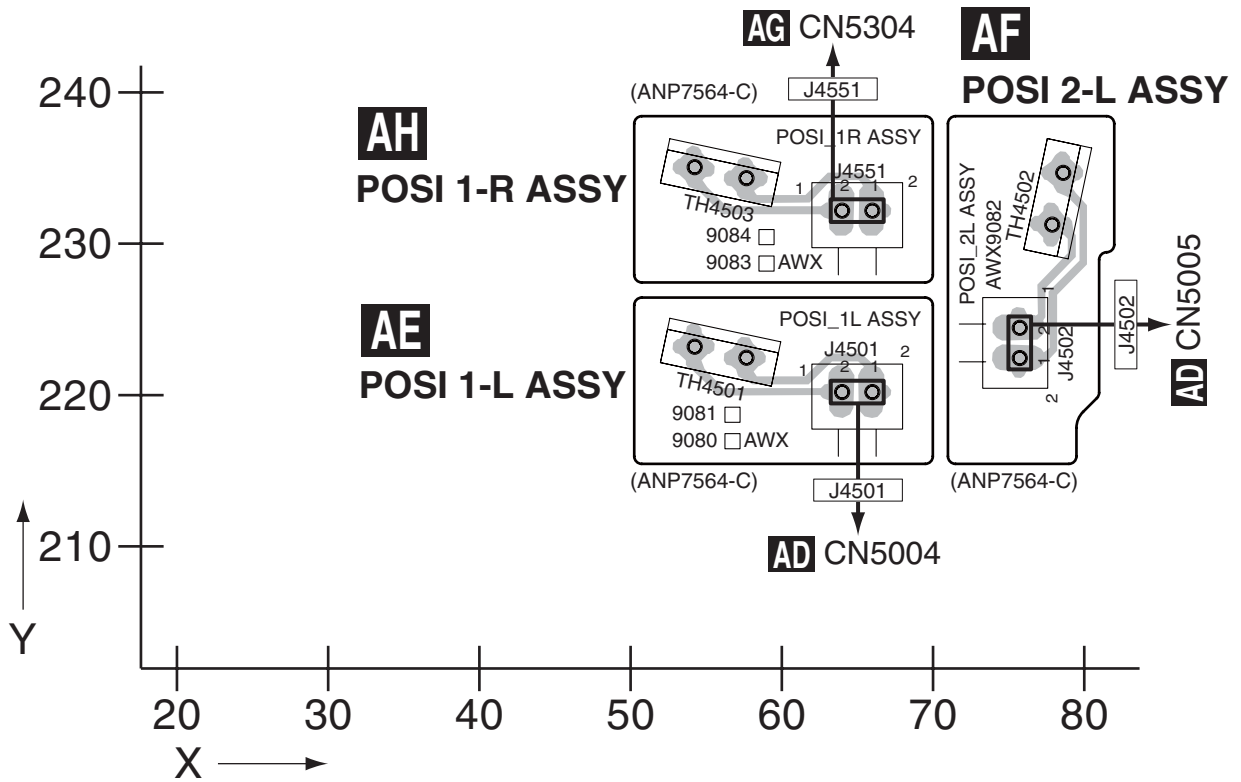

SIDE B

SIDE B

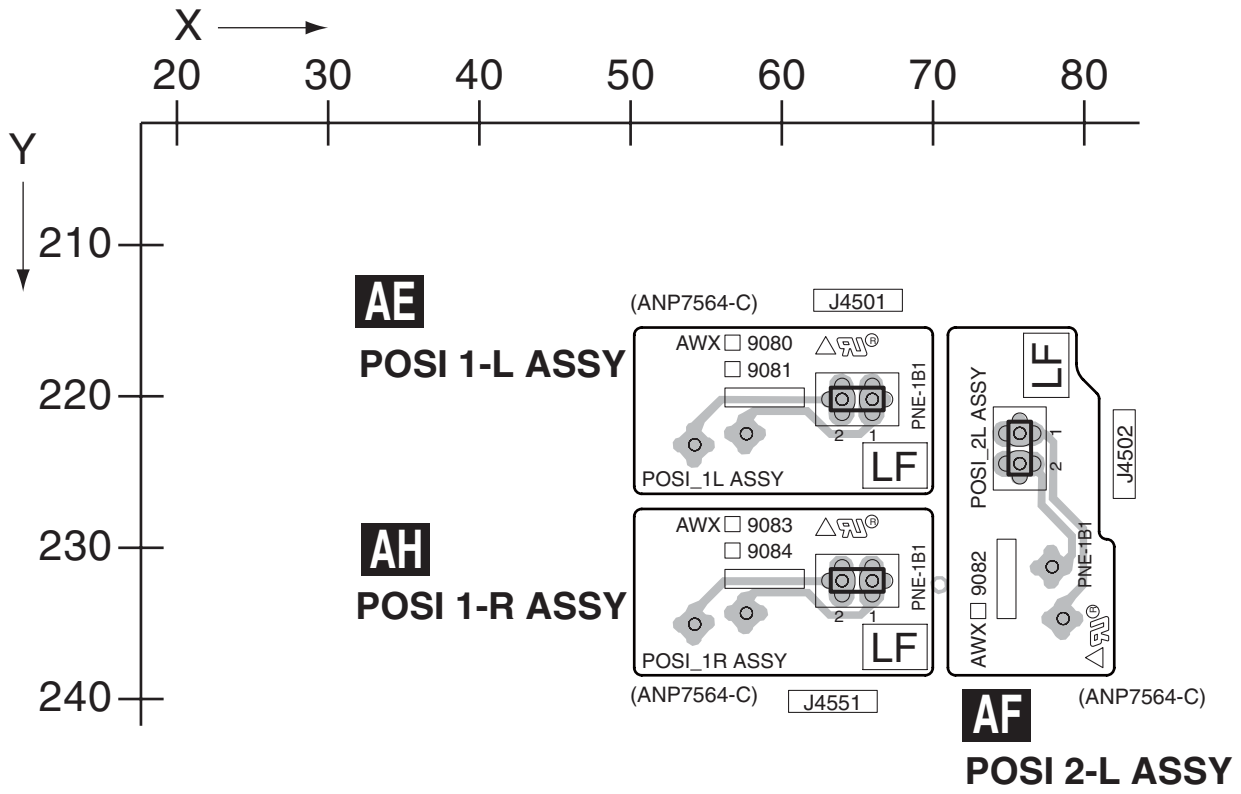

**AE AF AH**

**AE AF AH**

# 11.22 TRANS SIDE ASSY

**SIDE A**

## Y TRANS SIDE ASSY

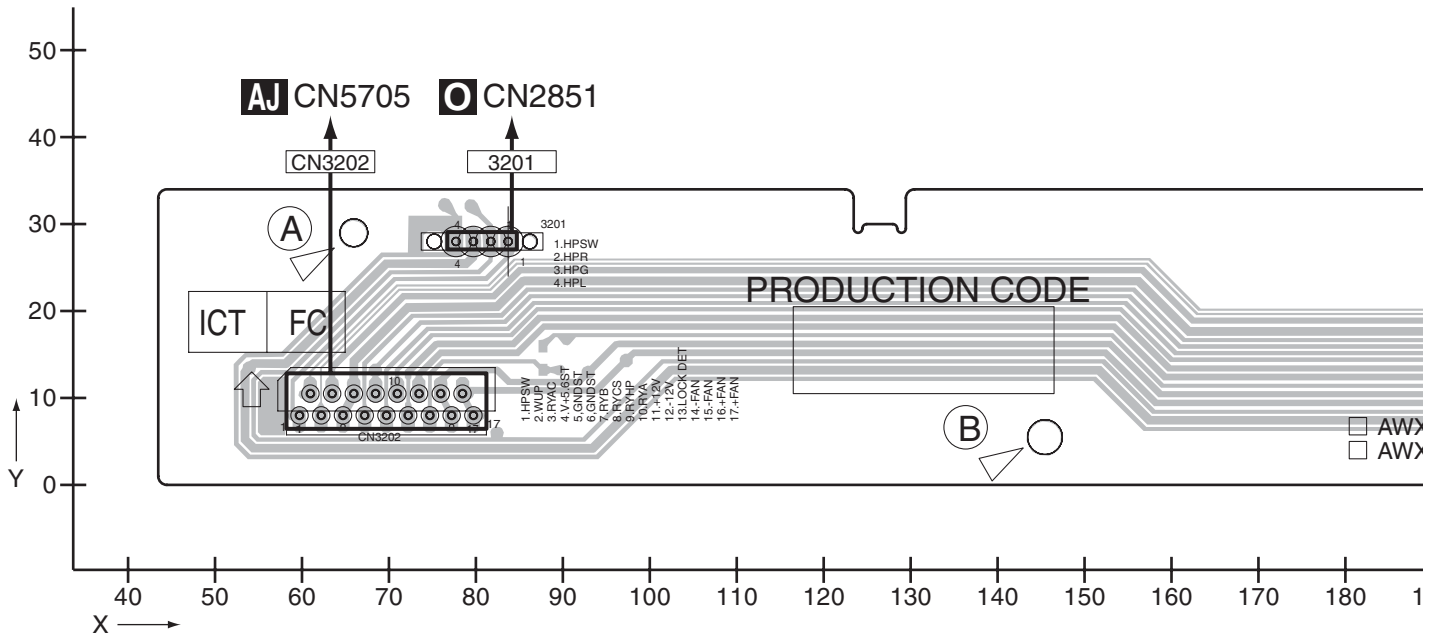

**SIDE B**

## Y TRANS SIDE ASSY

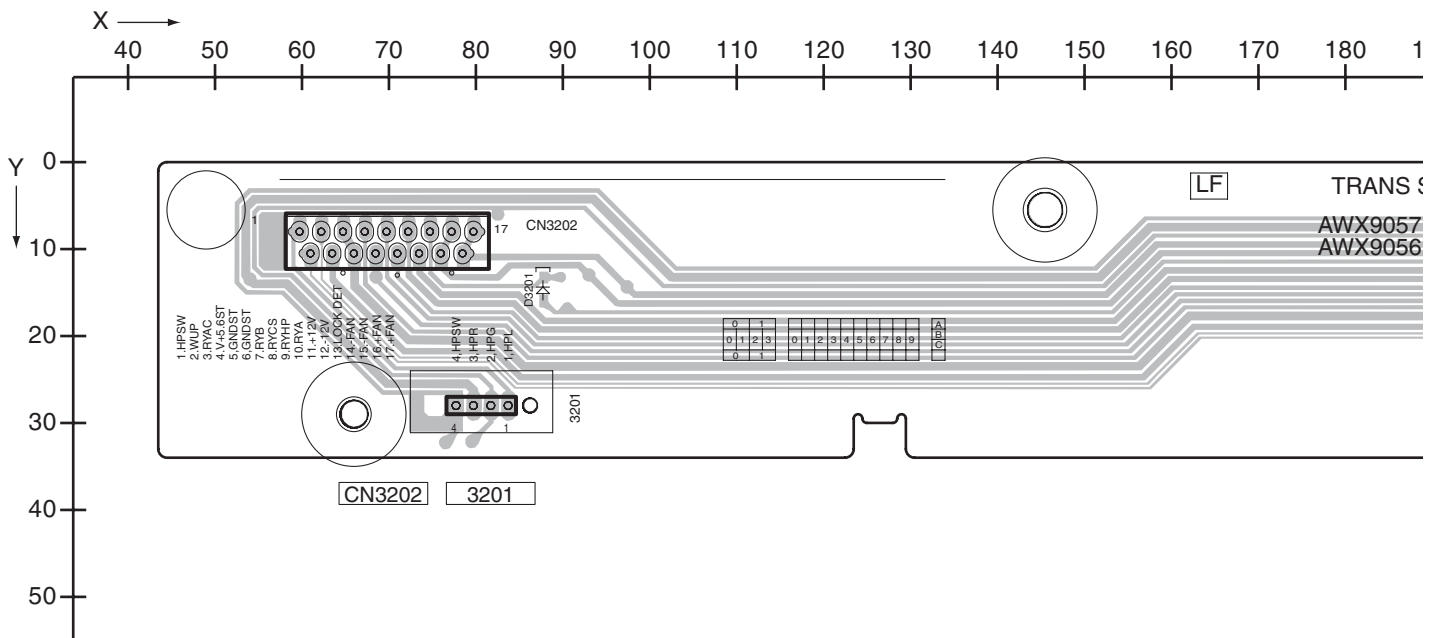

**Y**

202

VSX-LX50

**SIDE A**

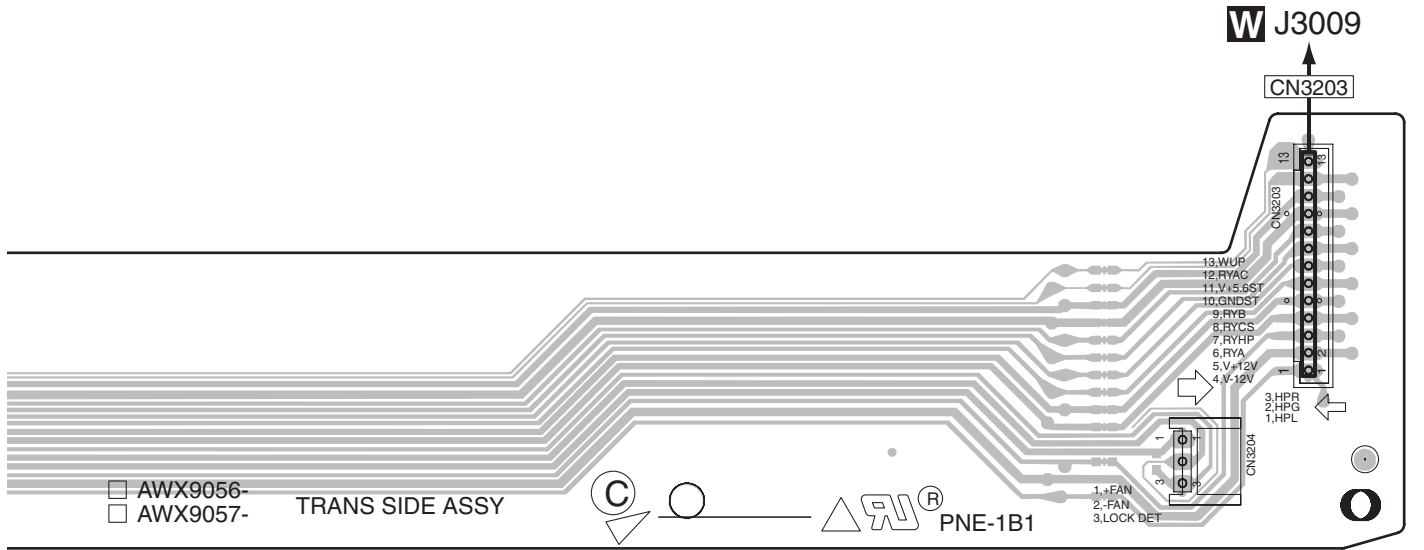

(ANP7563-C)

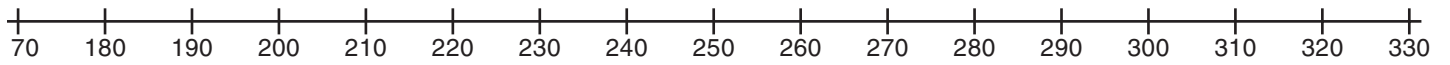

**SIDE B**

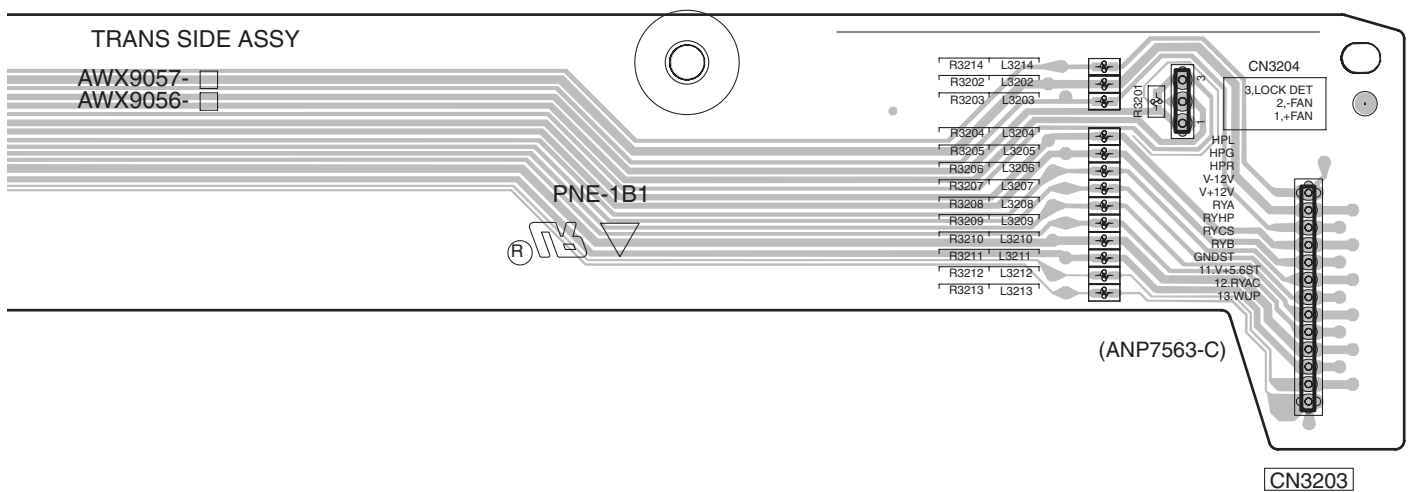
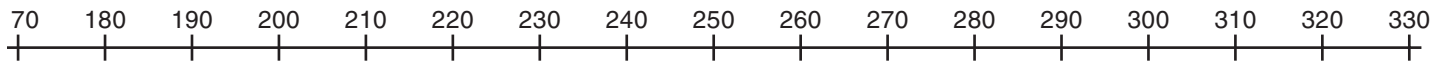

(ANP7563-C)

**Y**

# 11.23 IR I/O ASSY

**SIDE A**

**SIDE A**

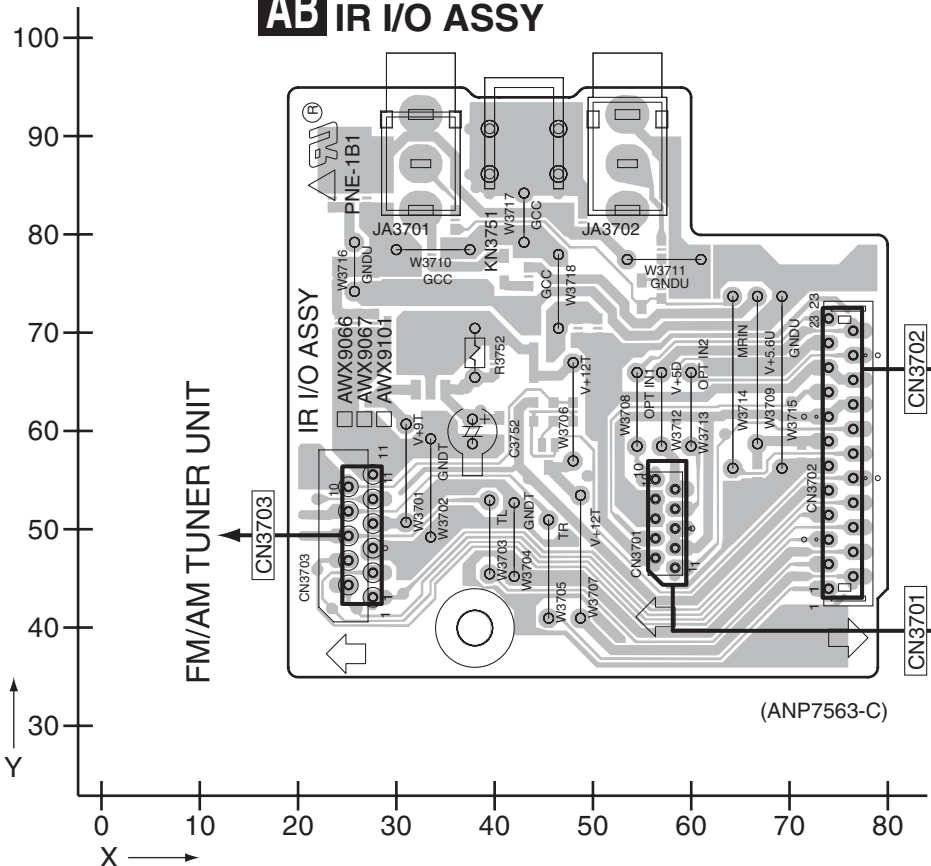

**SIDE B**

**SIDE B**

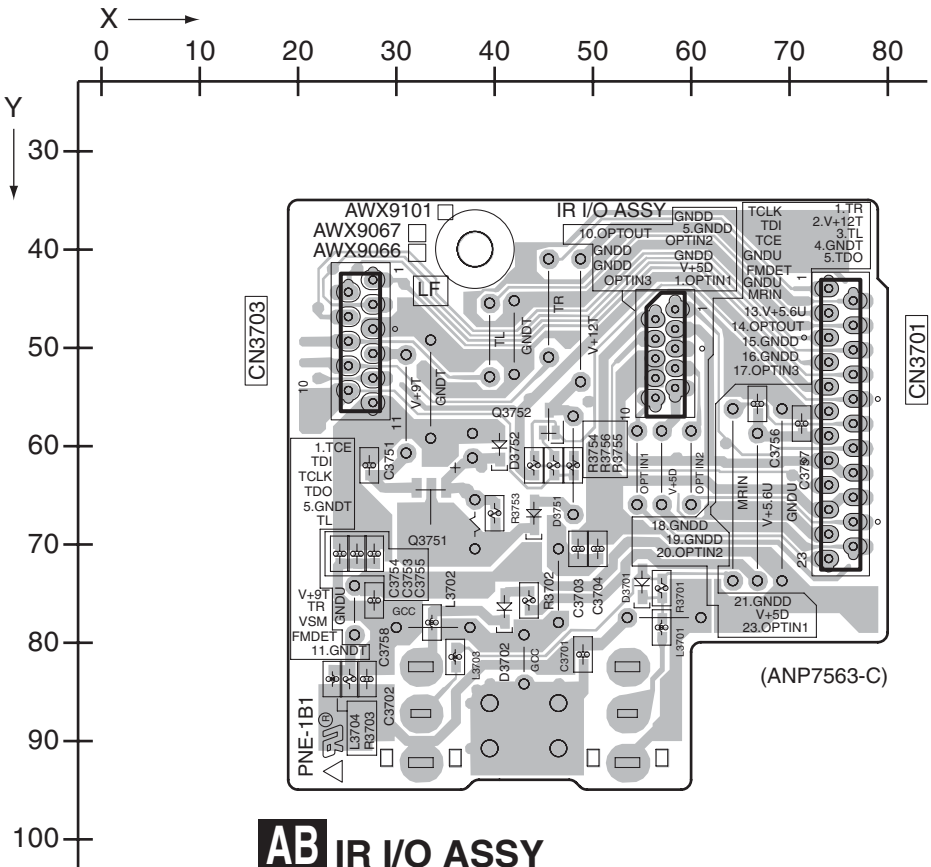

**AB** IR I/O ASSY

**AB**

■

5

■

6

■

7

■

8

■

A

■

B

■

C

■

D

■

E

■

F

■

5

■

6

VSX-LX50

■

7

■

8

■

# 11.24 LOCAL P-SUPPLY ASSY

**SIDE A**

**SIDE A**

## Z LOCAL P-SUPPLY ASSY

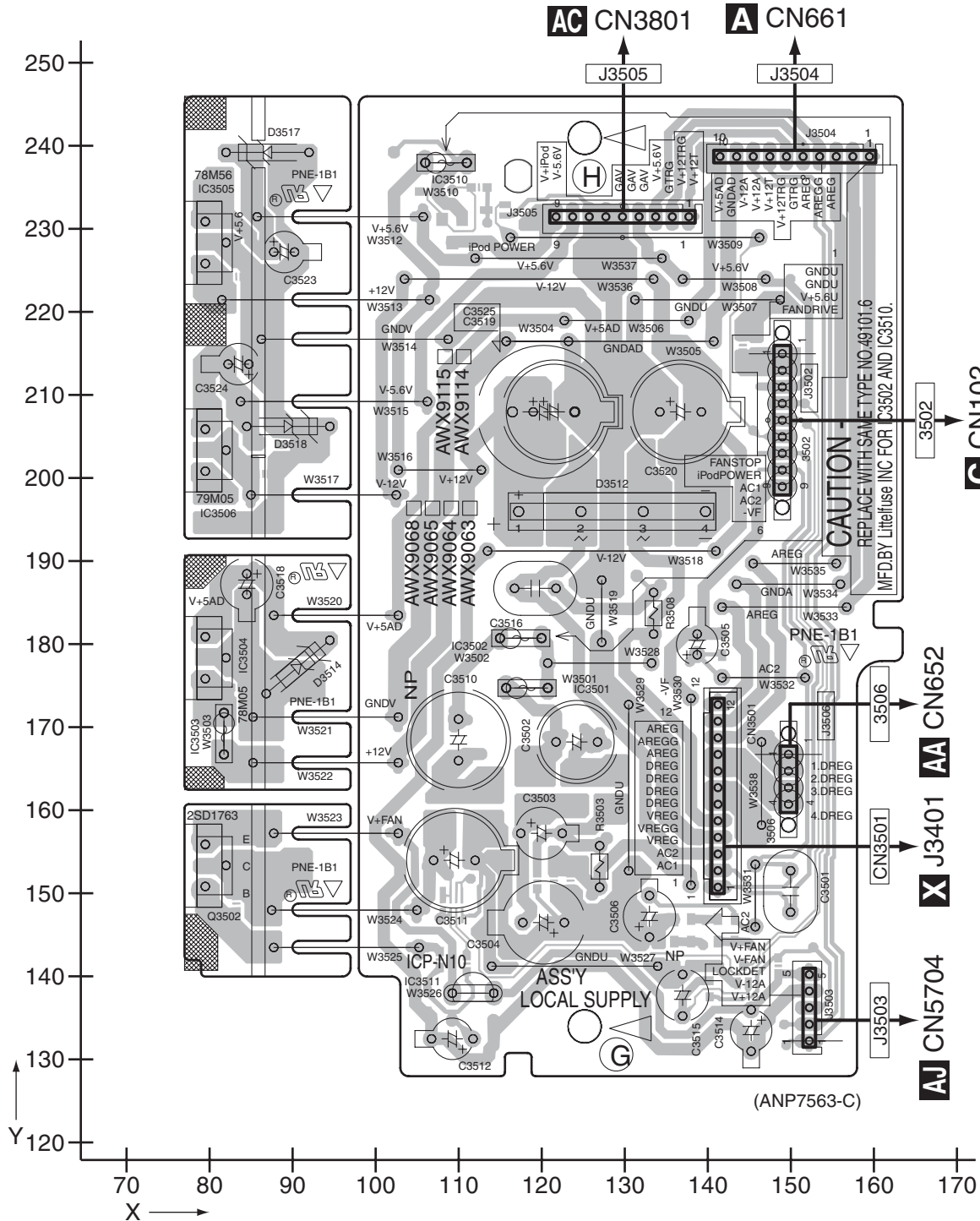

**Z**

**Z**

SIDE B

SIDE B

# Z LOCAL P-SUPPLY ASSY

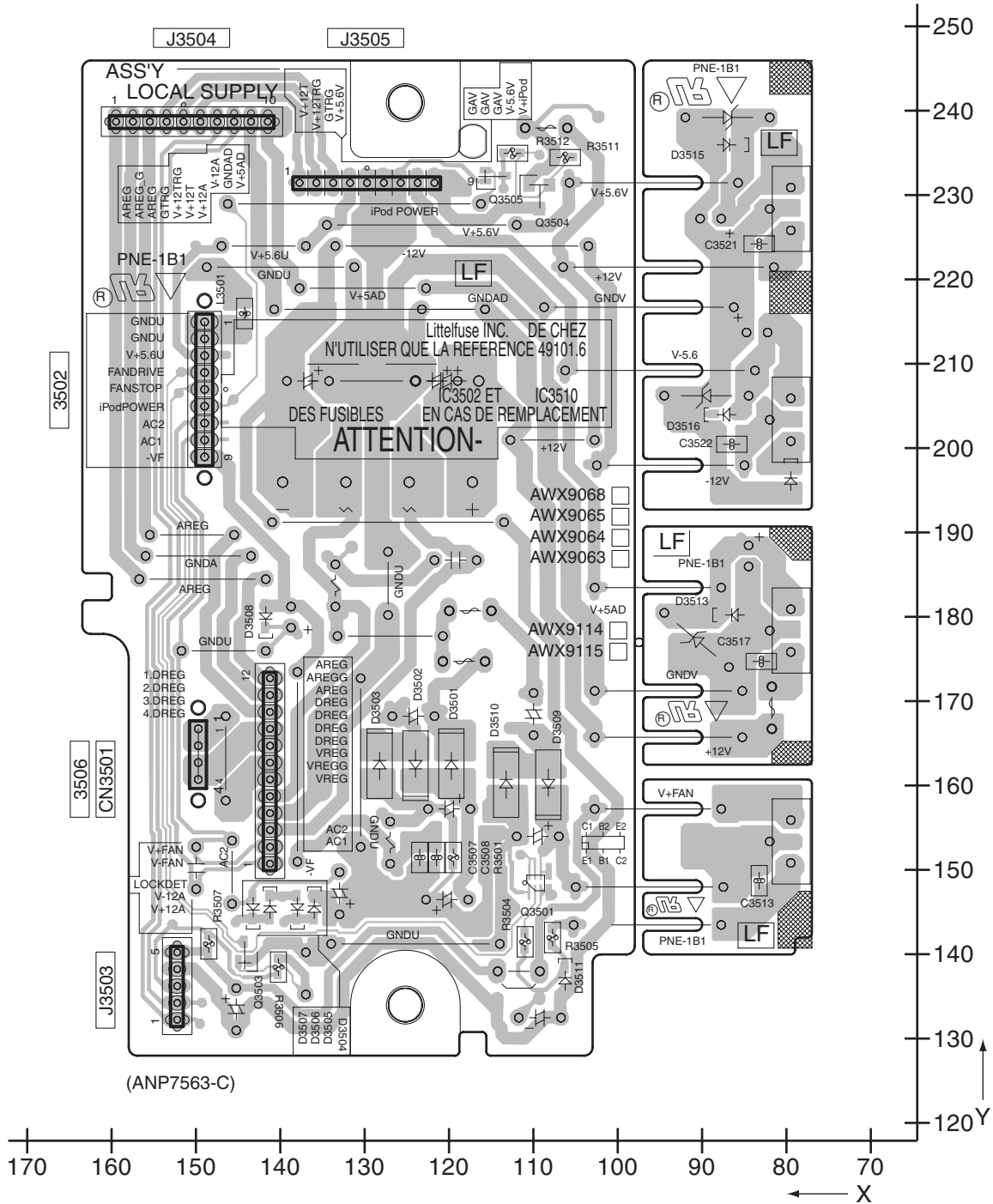

Z

VSX-LX50

Z

11.25 DC/DC ASSY

SIDE A

SIDE A

AA DC/DC ASSY

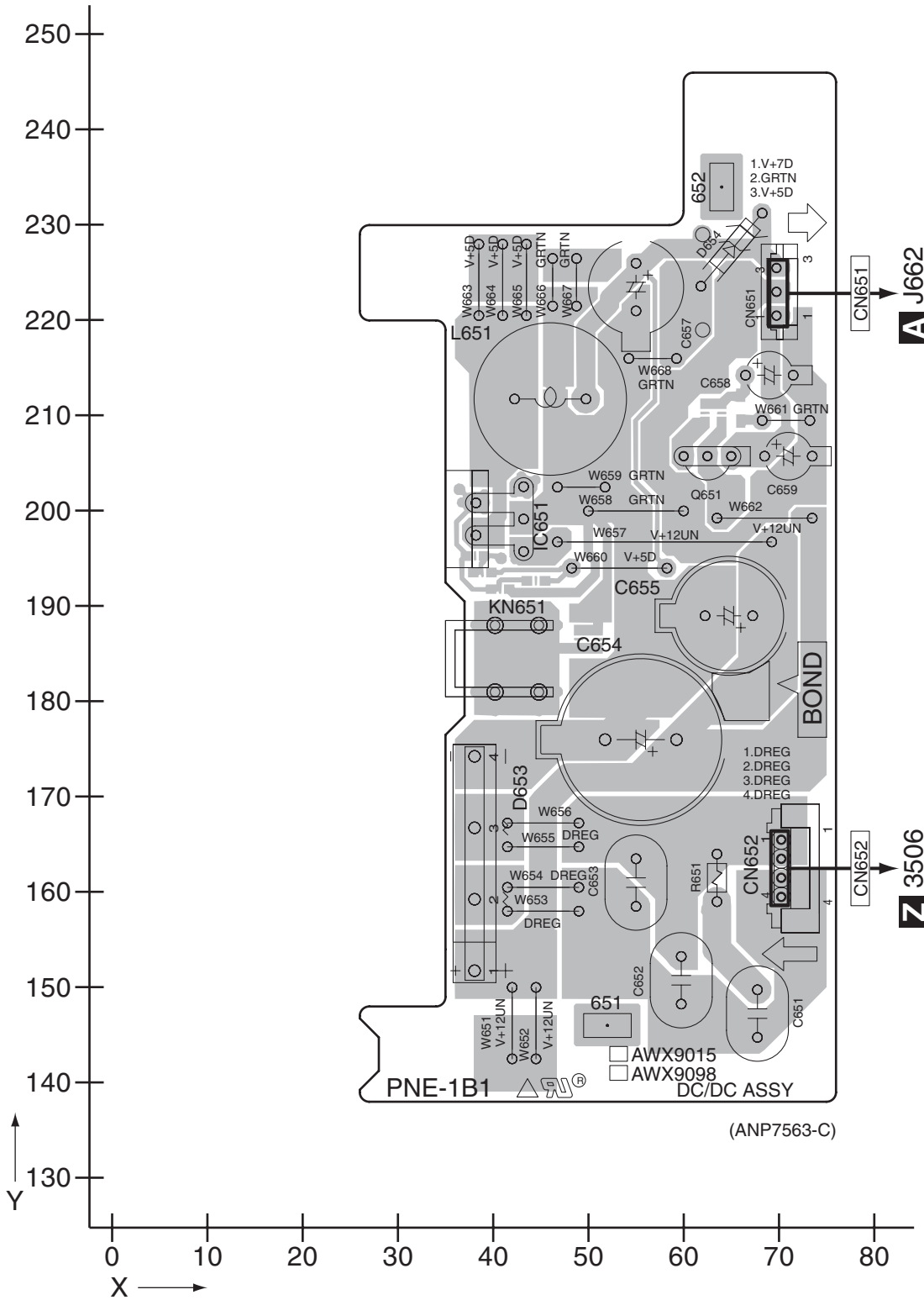

AA

AA

SIDE B

SIDE B

# AA DC/DC ASSY

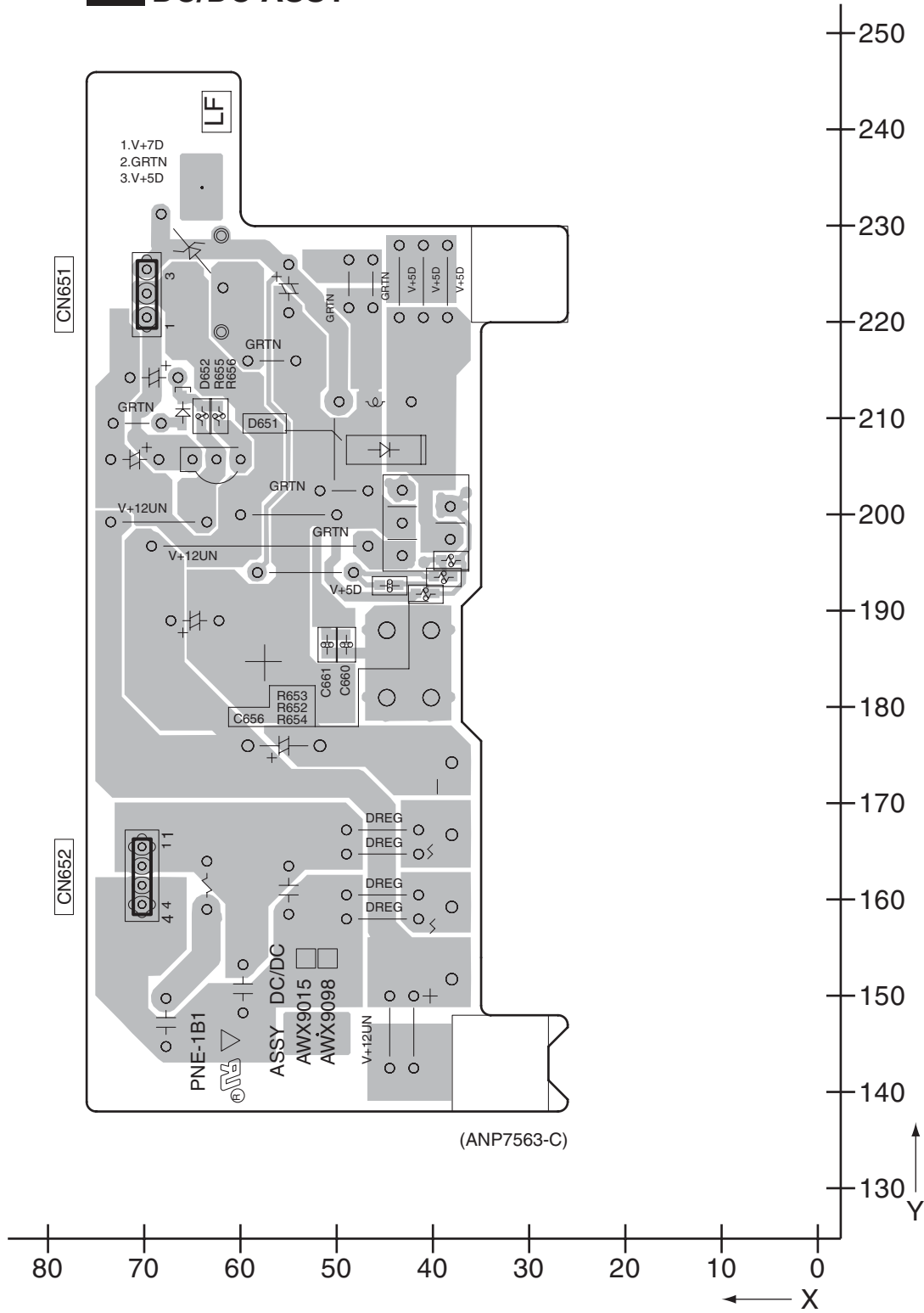

AA

AA

# 11.26 VIDEO CONNECT ASSY

SIDE A

SIDE A

## AC VIDEO CONNECT ASSY

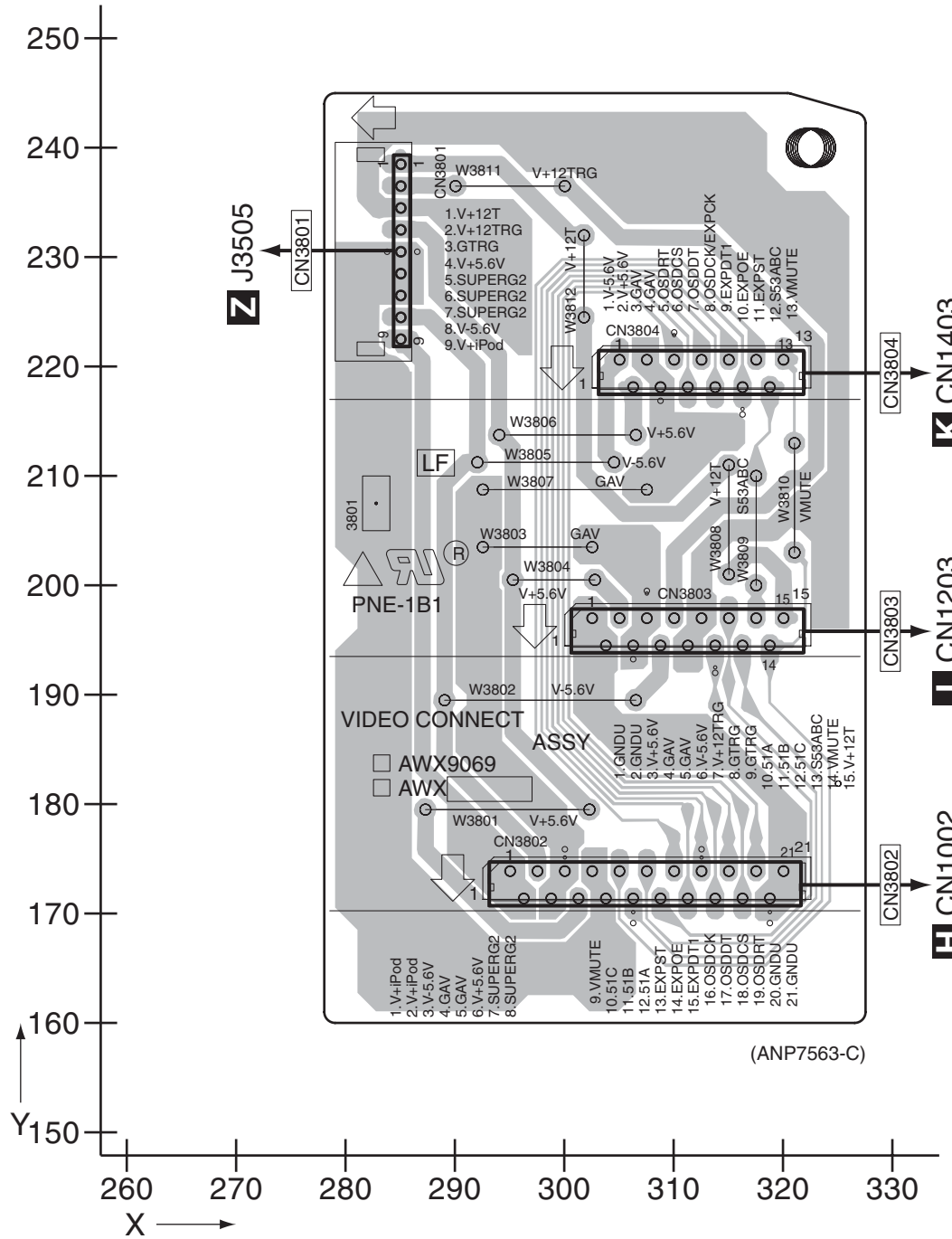

AC

AC

SIDE B

SIDE B

# AC VIDEO CONNECT ASSY

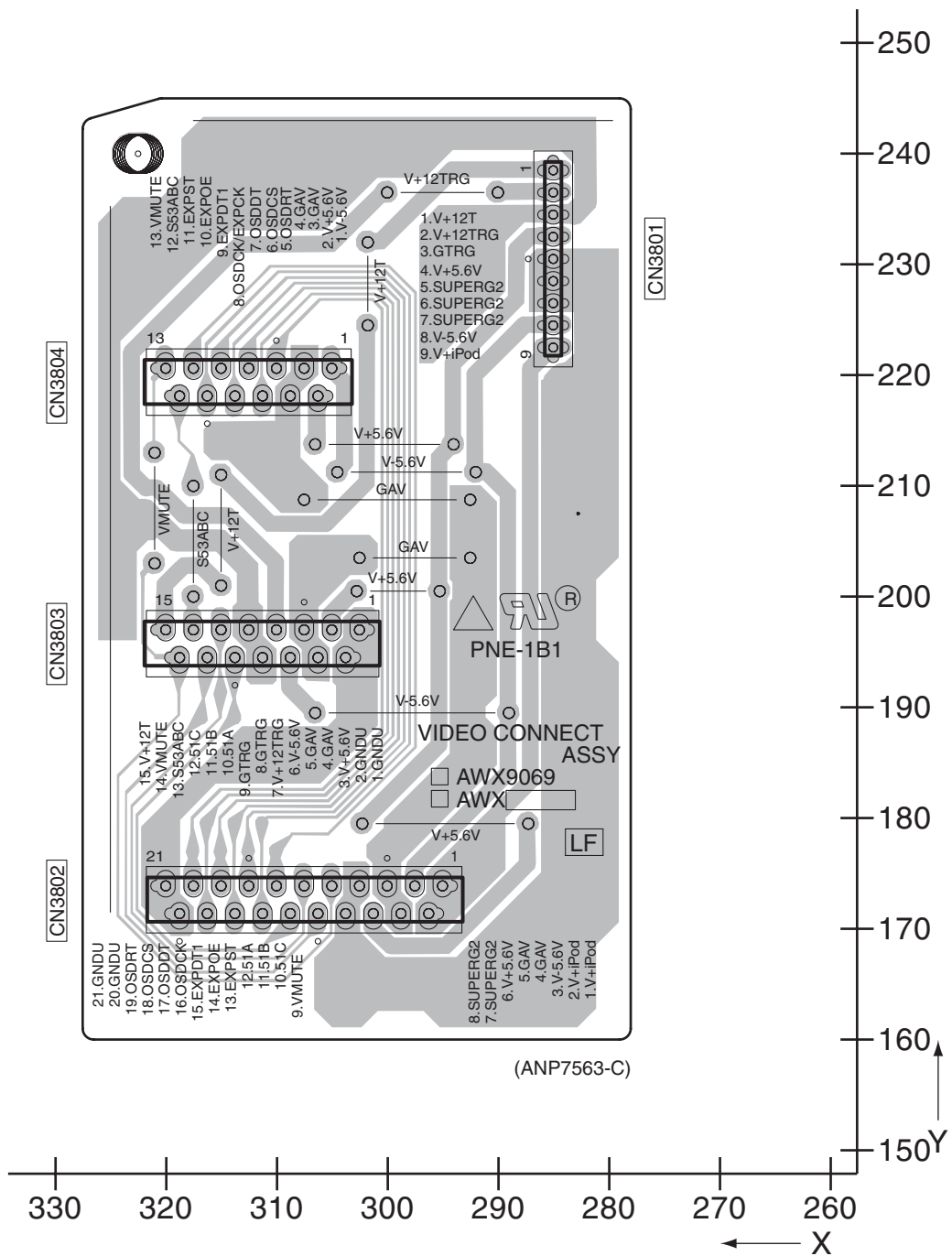

AC

AC

11.27 POWER AMP-L ASSY

SIDE A

AD POWER AMP-L ASSY

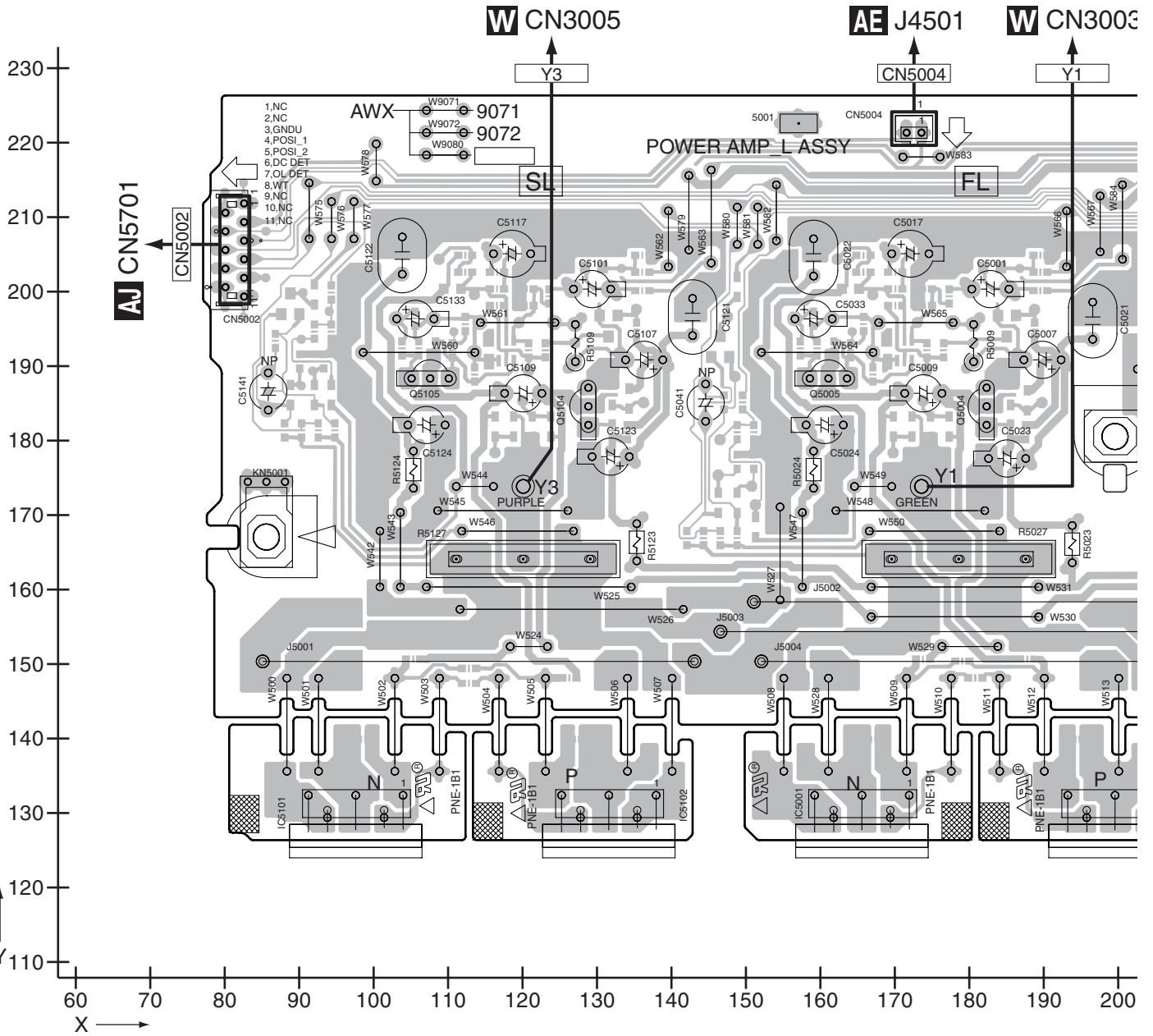

AD

SIDE A

A

B

C

D

E

F

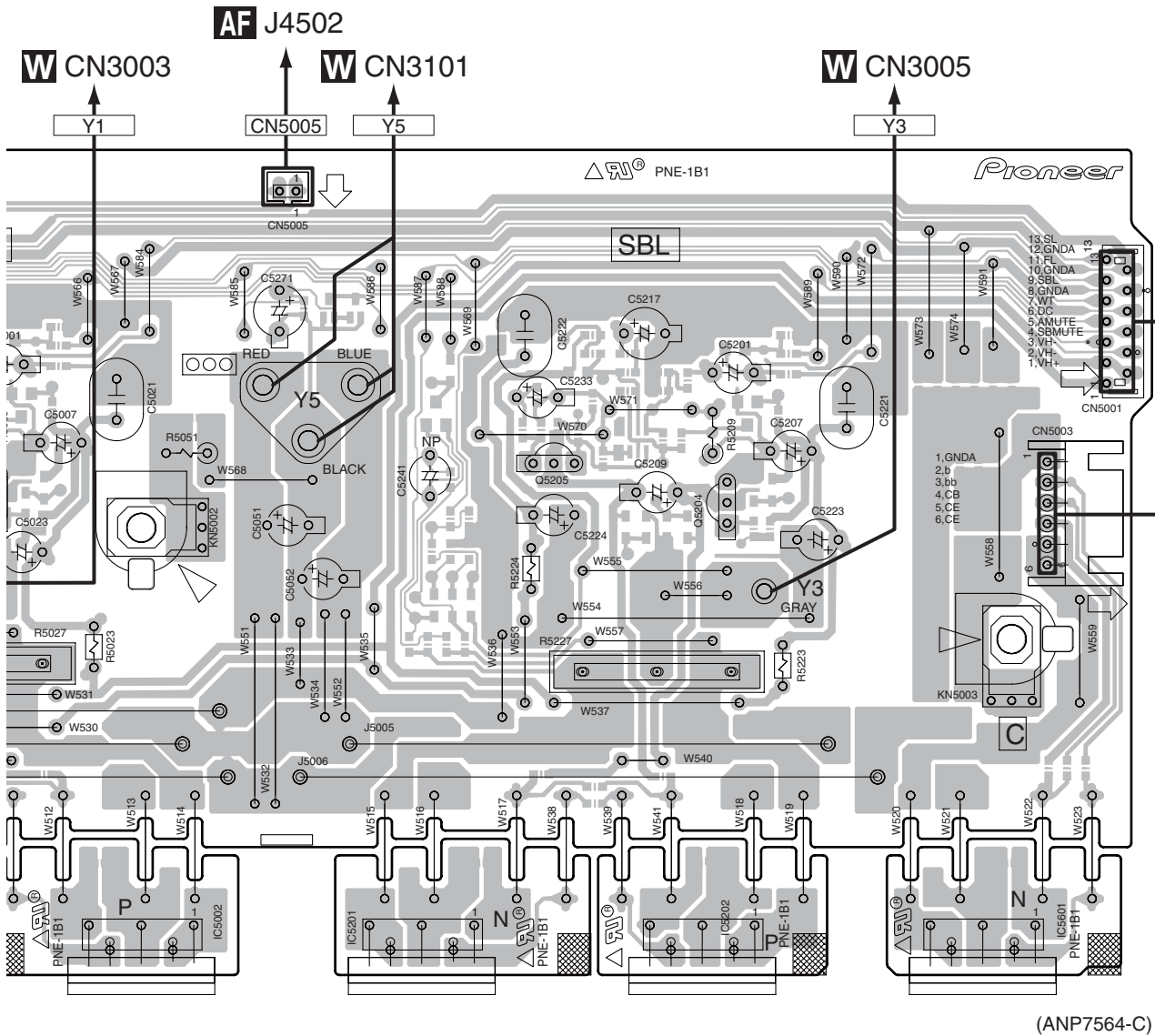

(ANP7564-C)

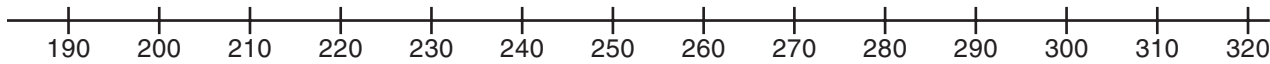

SIDE B

# AD POWER AMP-L ASSY

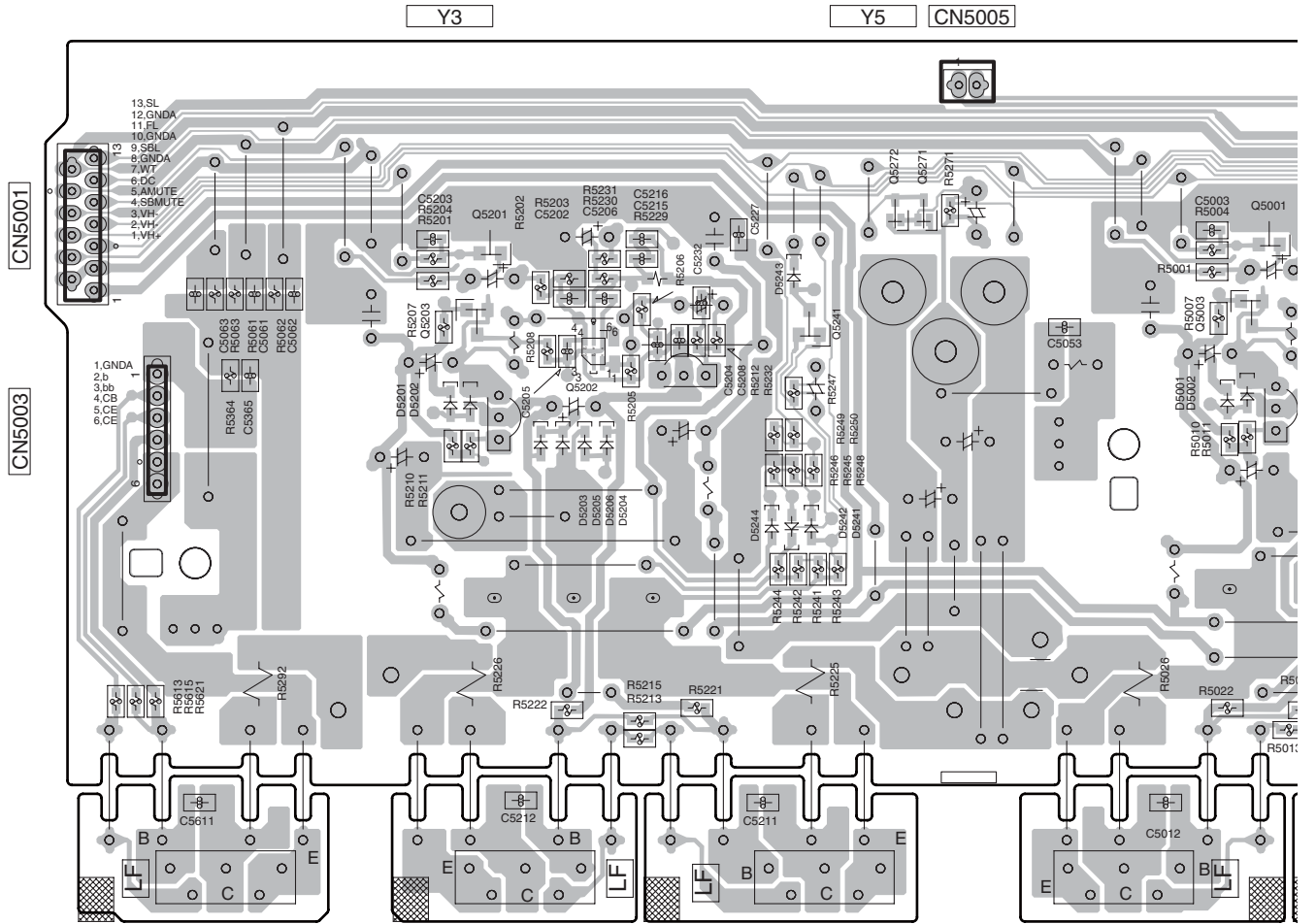

320 310 300 290 280 270 260 250 240 230 220 210 200 190 180

AD

SIDE B

A

B

C

D

E

F

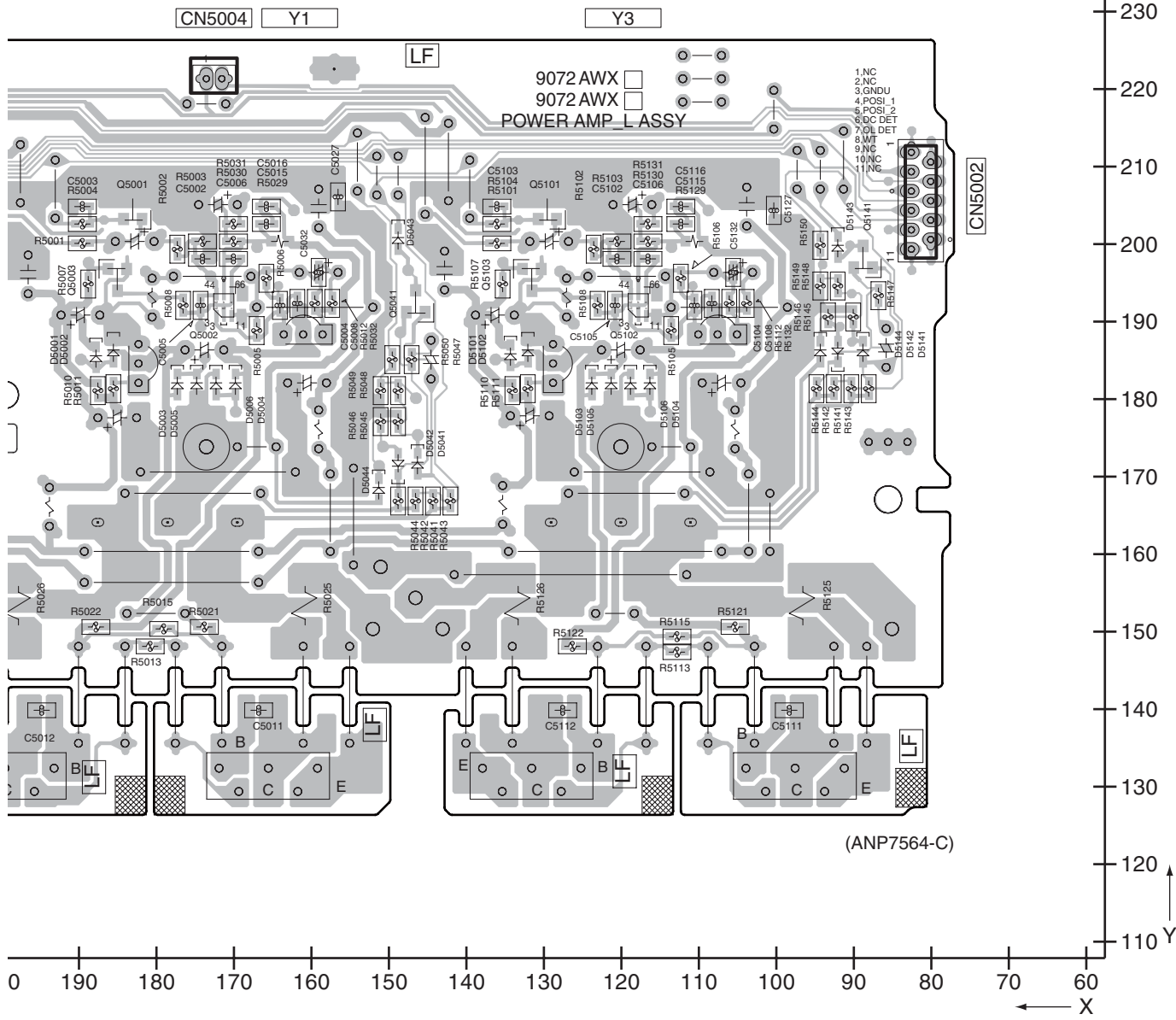

# 11.28 POWER AMP-R ASSY

**SIDE A**

## AG POWER AMP-R ASSY

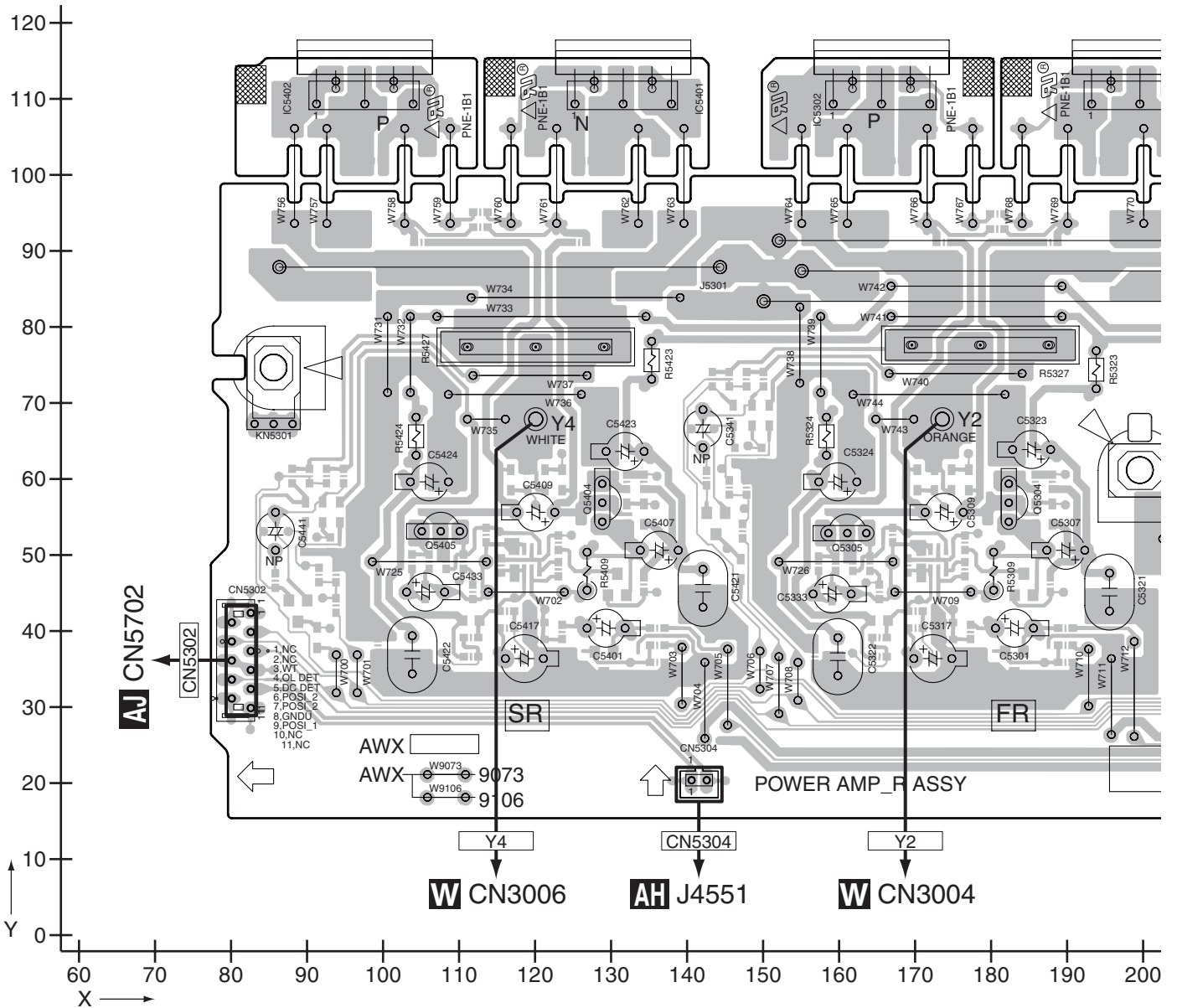



SIDE B

# AG POWER AMP-R ASSY

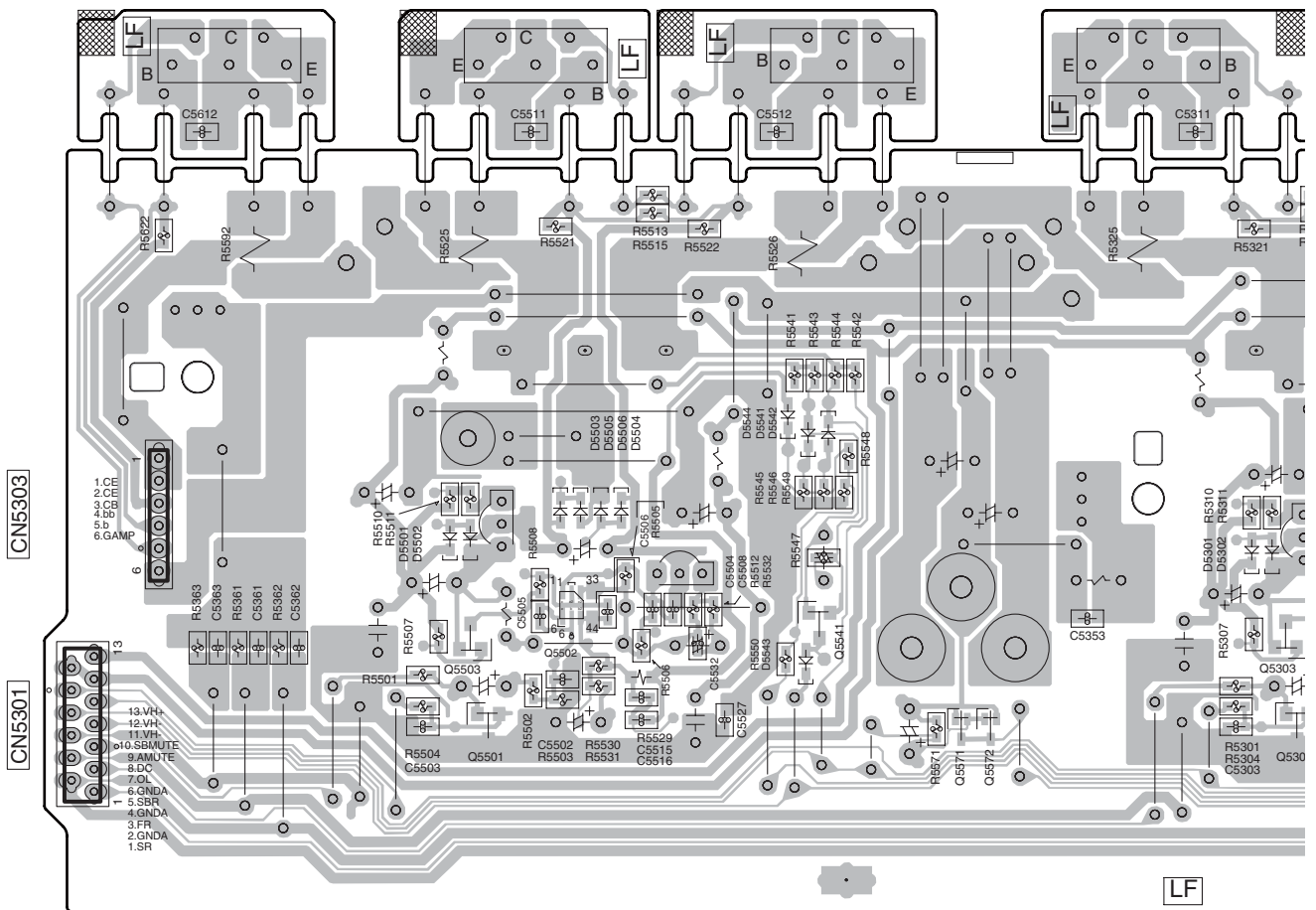

320 310 300 290 280 270 260 250 240 230 220 210 200 190

Y4

Y6

AG

SIDE B

A

B

C

D

E

F

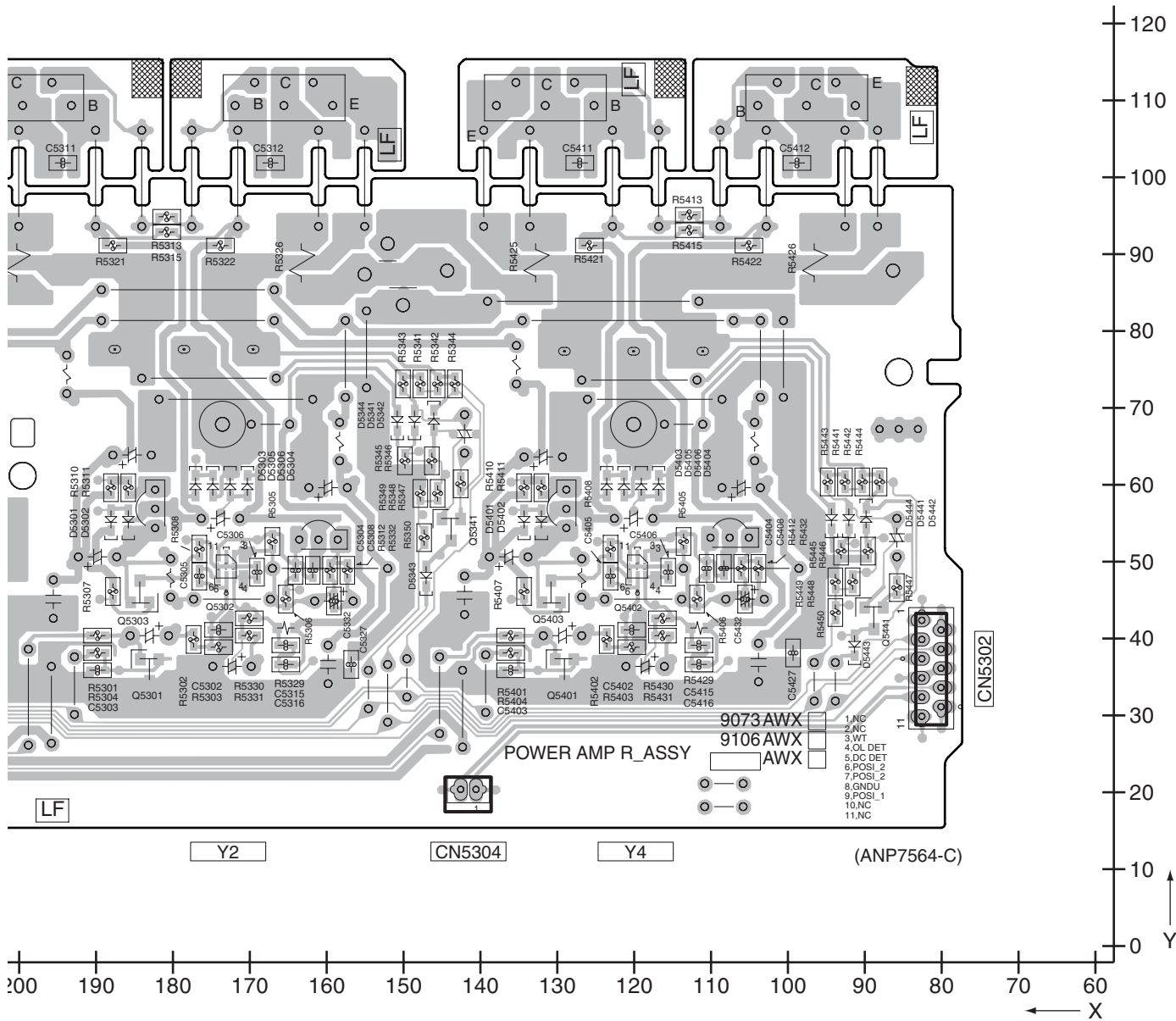

# 11.29 POWER AMP IN ASSY

SIDE A

SIDE A

## AI POWER AMP IN ASSY

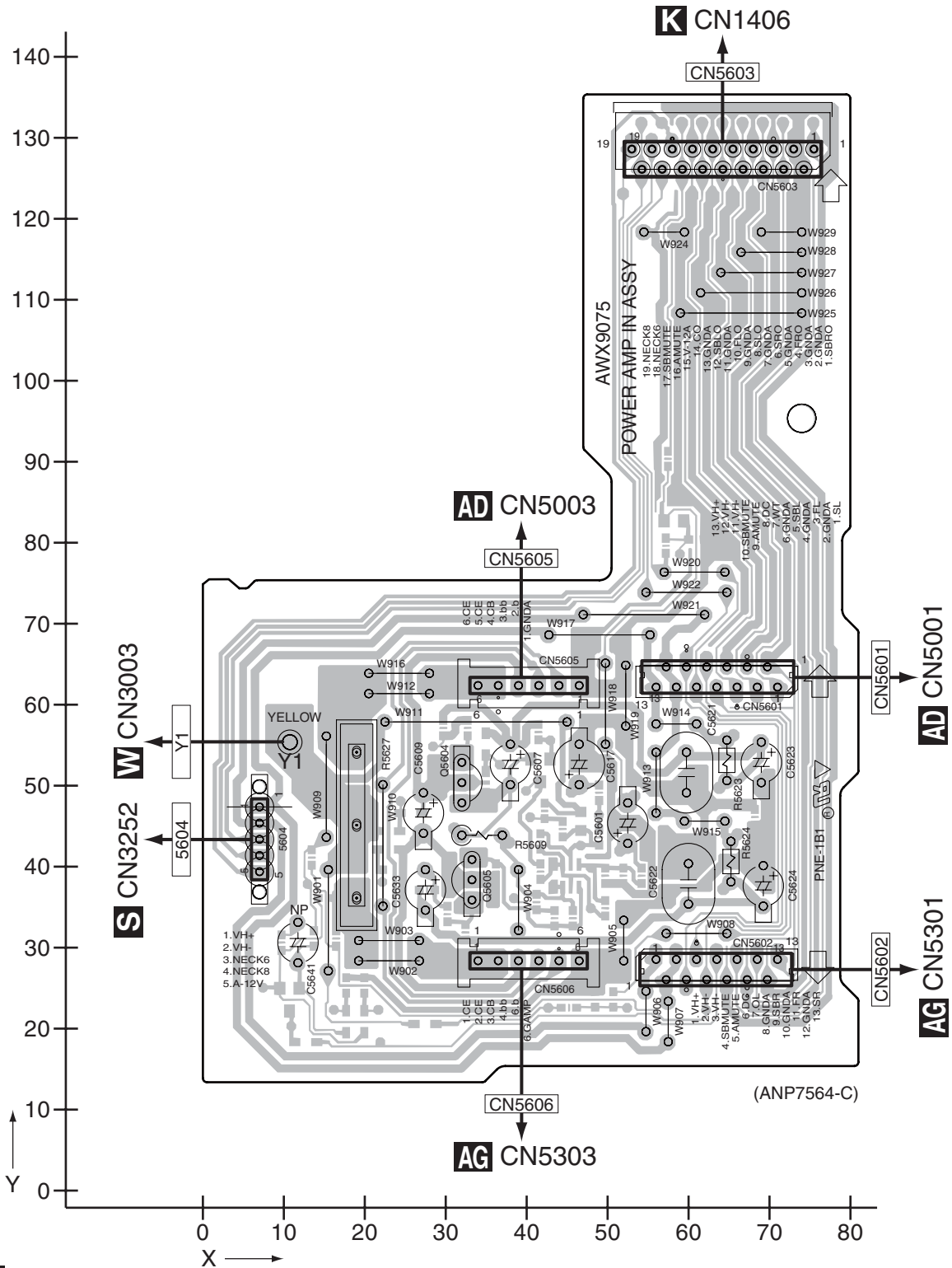

SIDE B

SIDE B

A

# AI POWER AMP IN ASSY

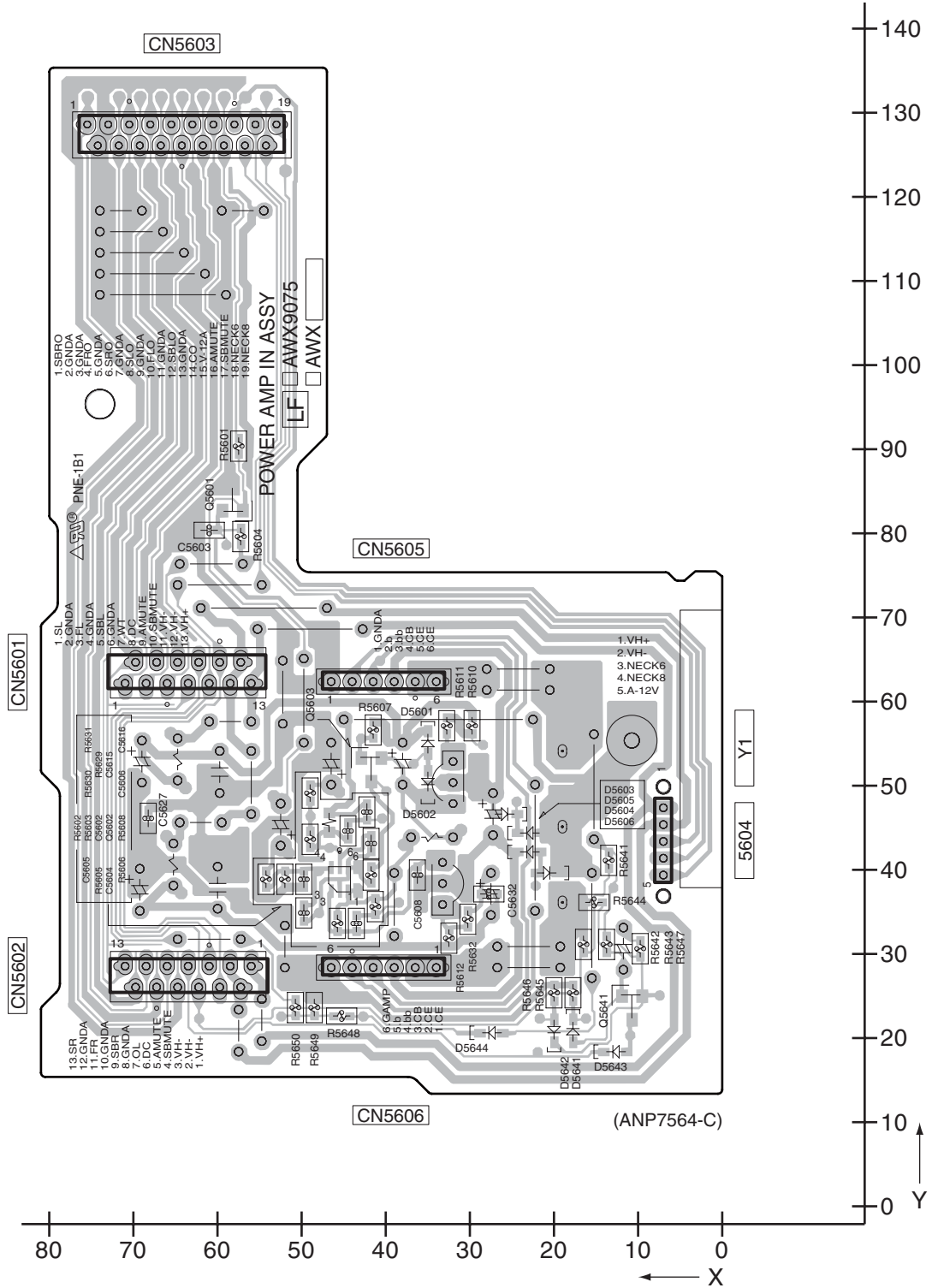

B

C

D

E

F

AI

AI

# 11.30 POWER PROTECT ASSY

SIDE A

SIDE A

## AJ POWER PROTECT ASSY

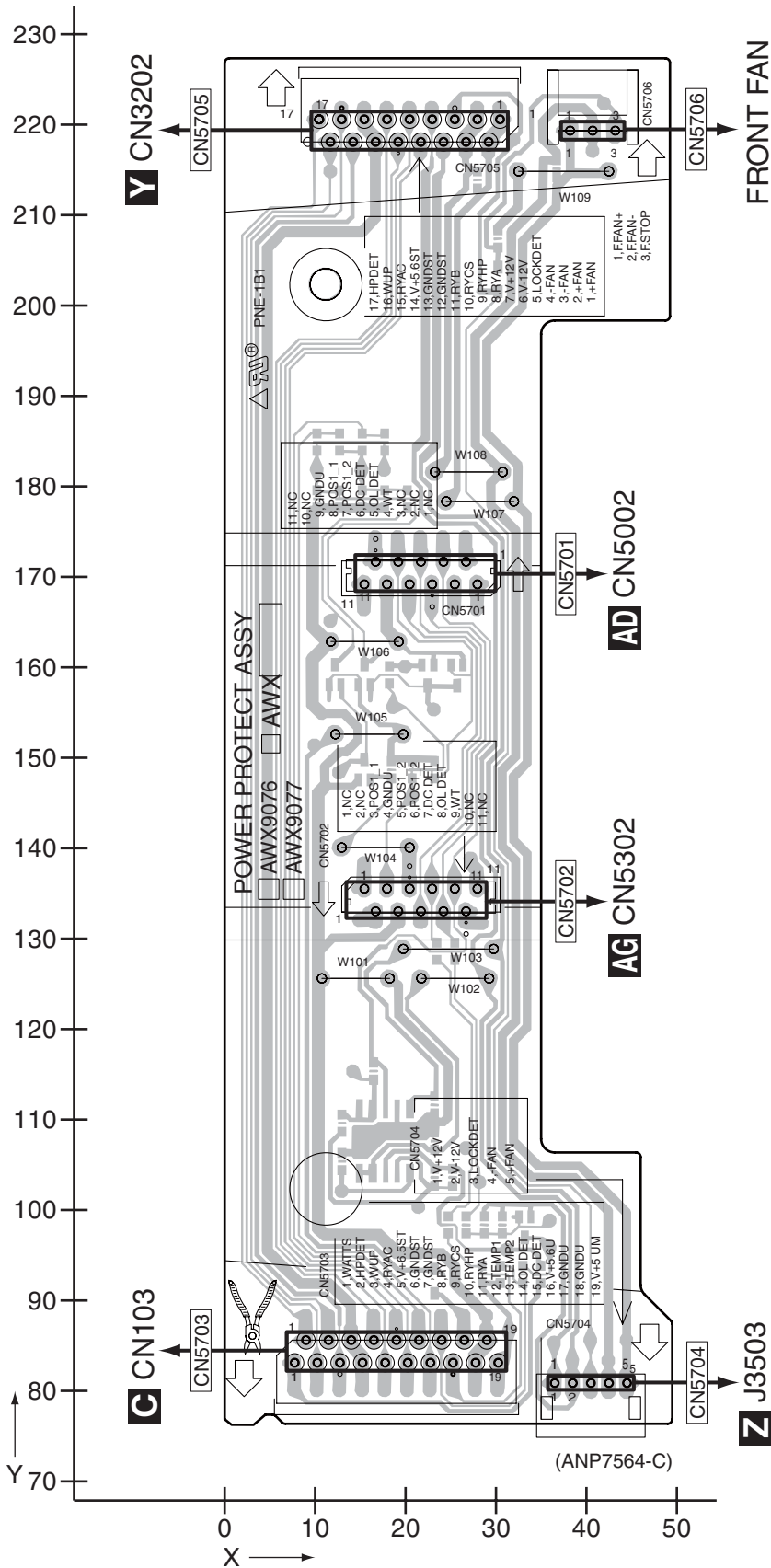

SIDE B

SIDE B

# AJ POWER PROTECT ASSY

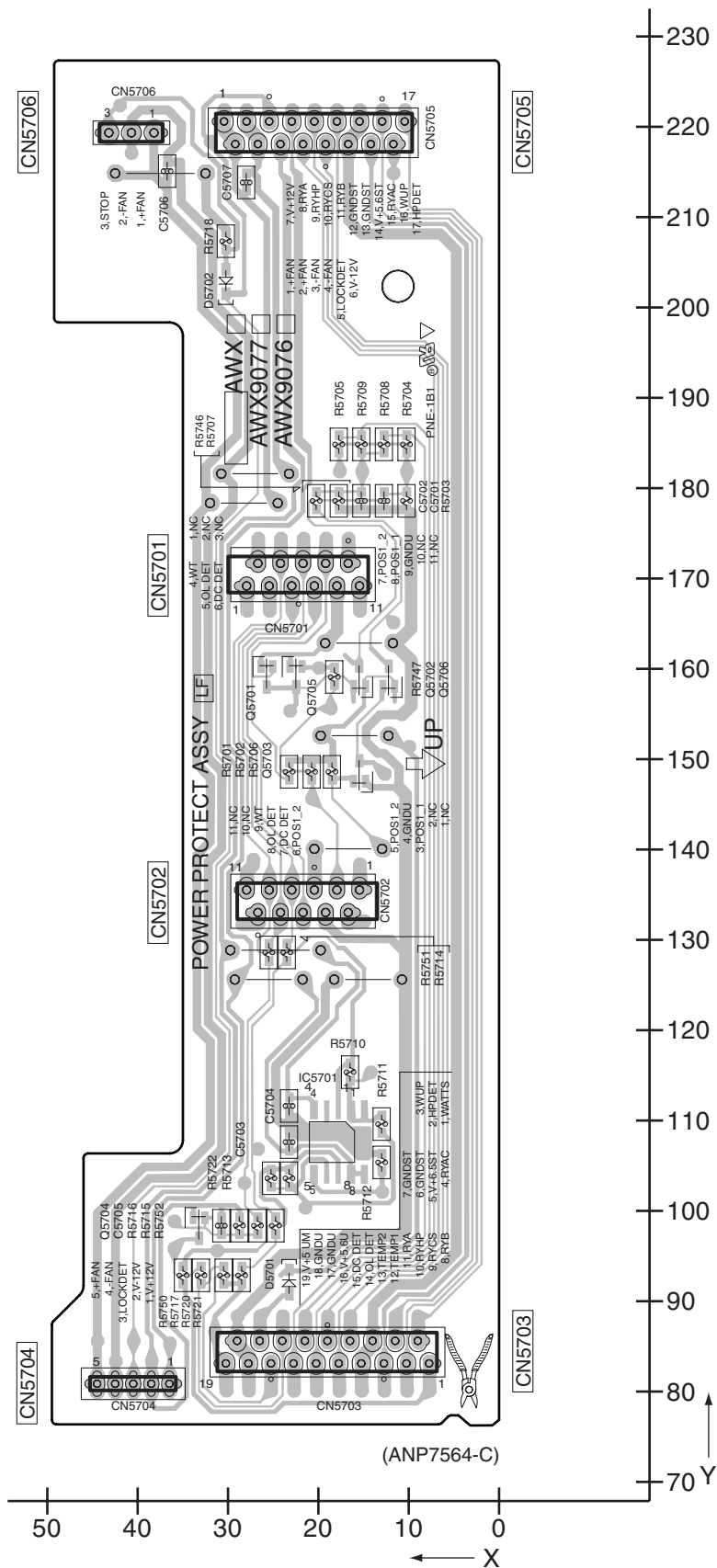

AJ

AJ

VSX-LX50

# 11.31 HDMI & DVC ASSY

SIDE A

## AK HDMI & DVC ASSY

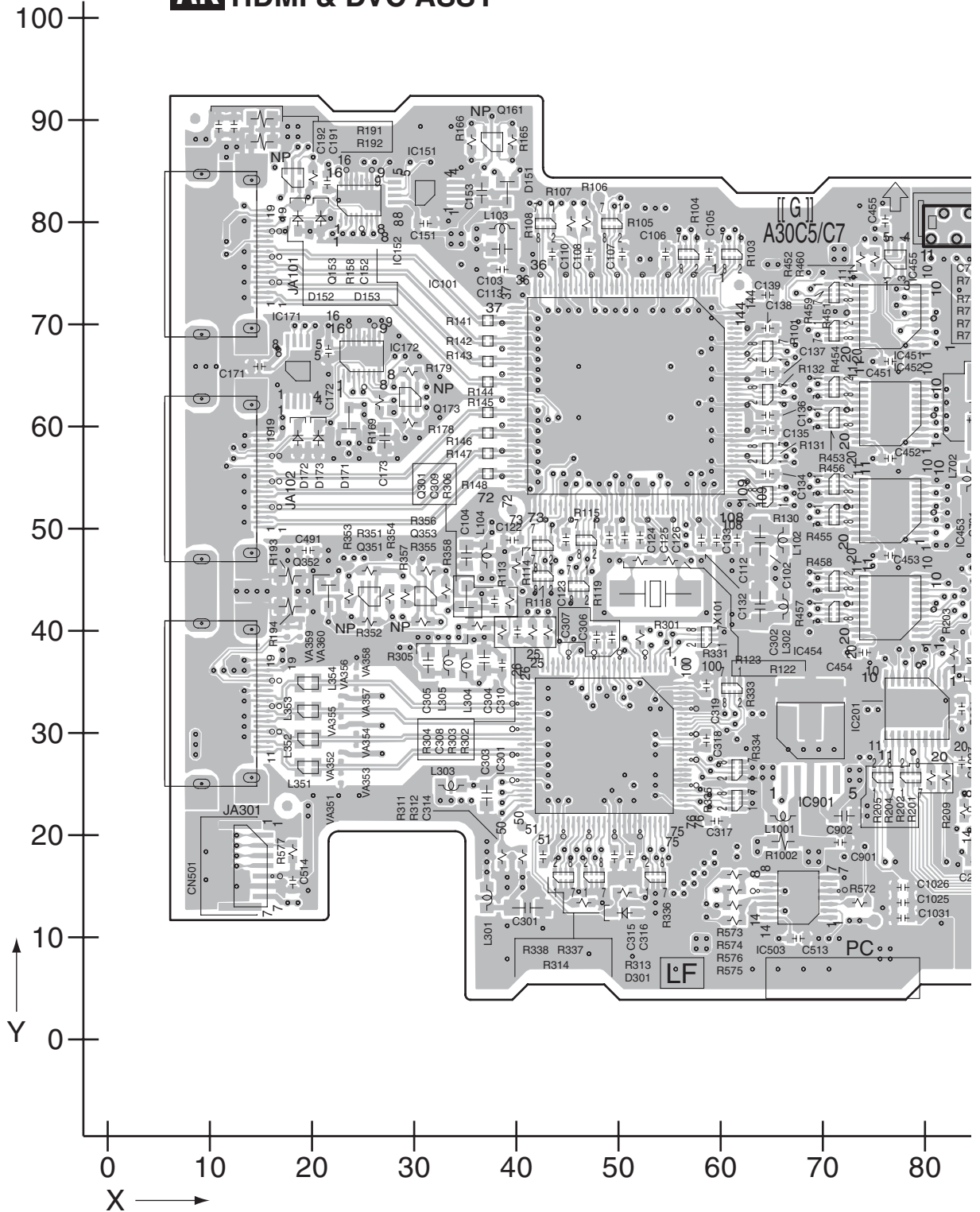

AK

224

VSX-LX50

A

B

C

D

E

F

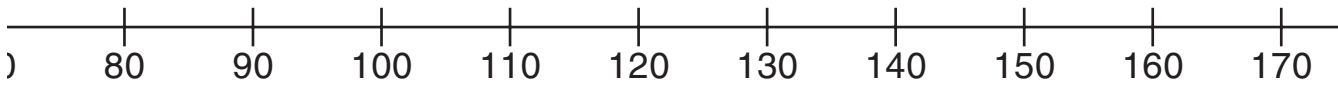
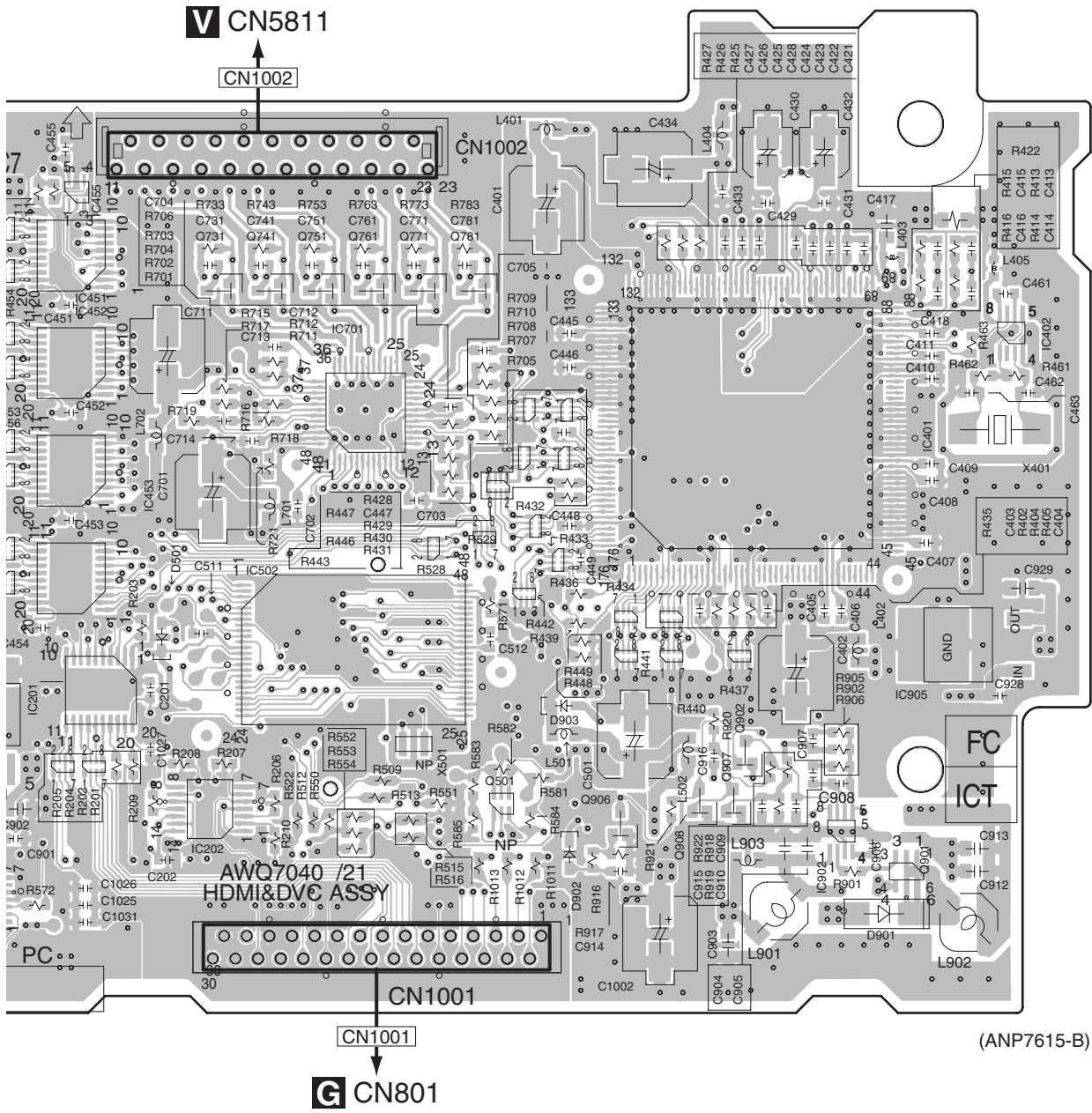

SIDE B

# AK HDMI & DVC ASSY

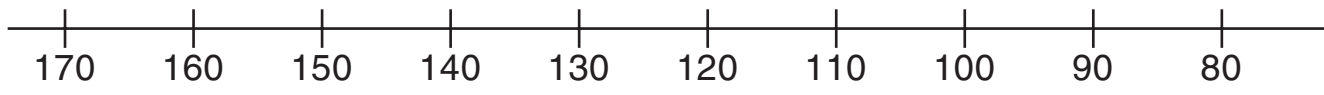
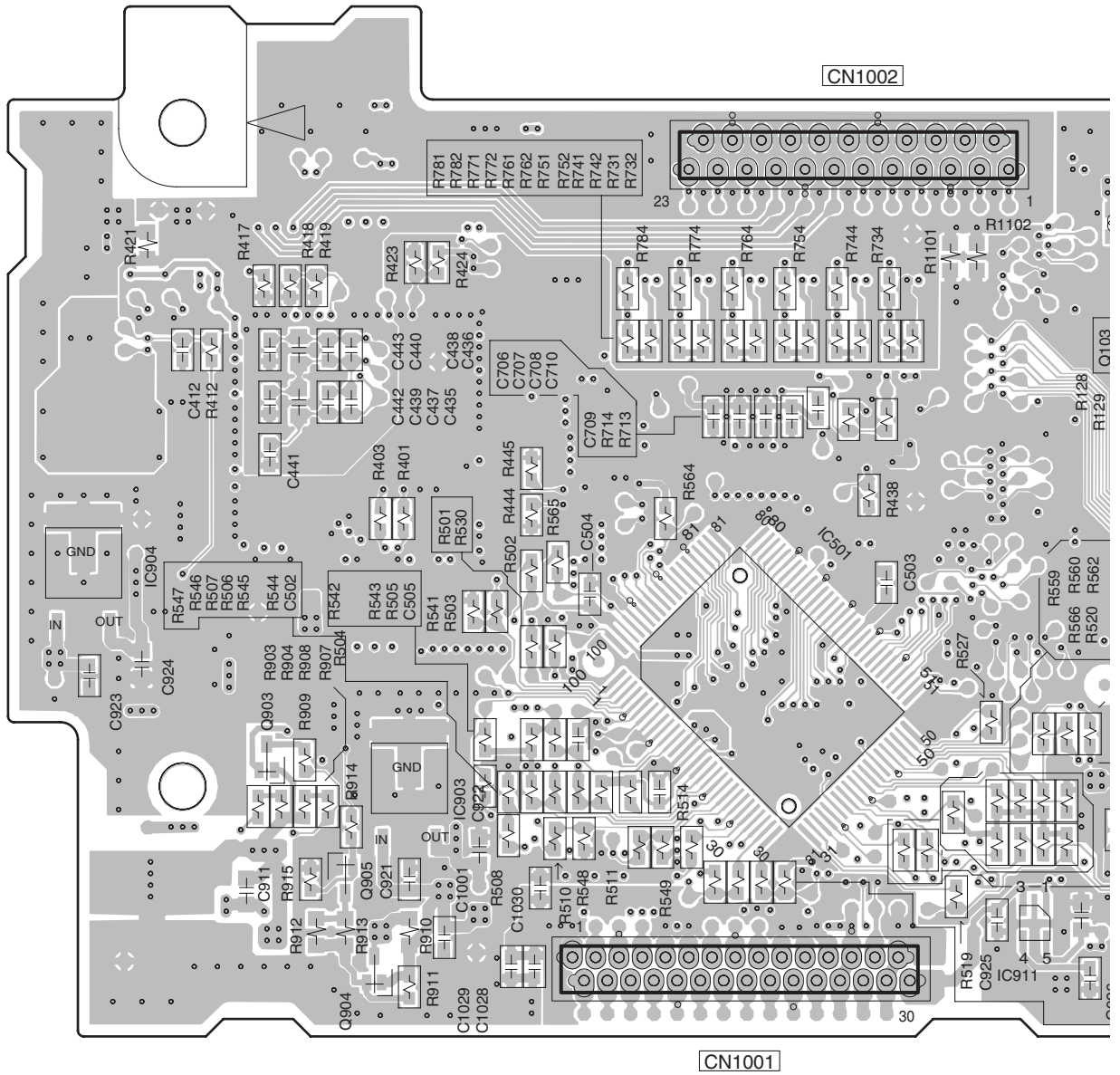

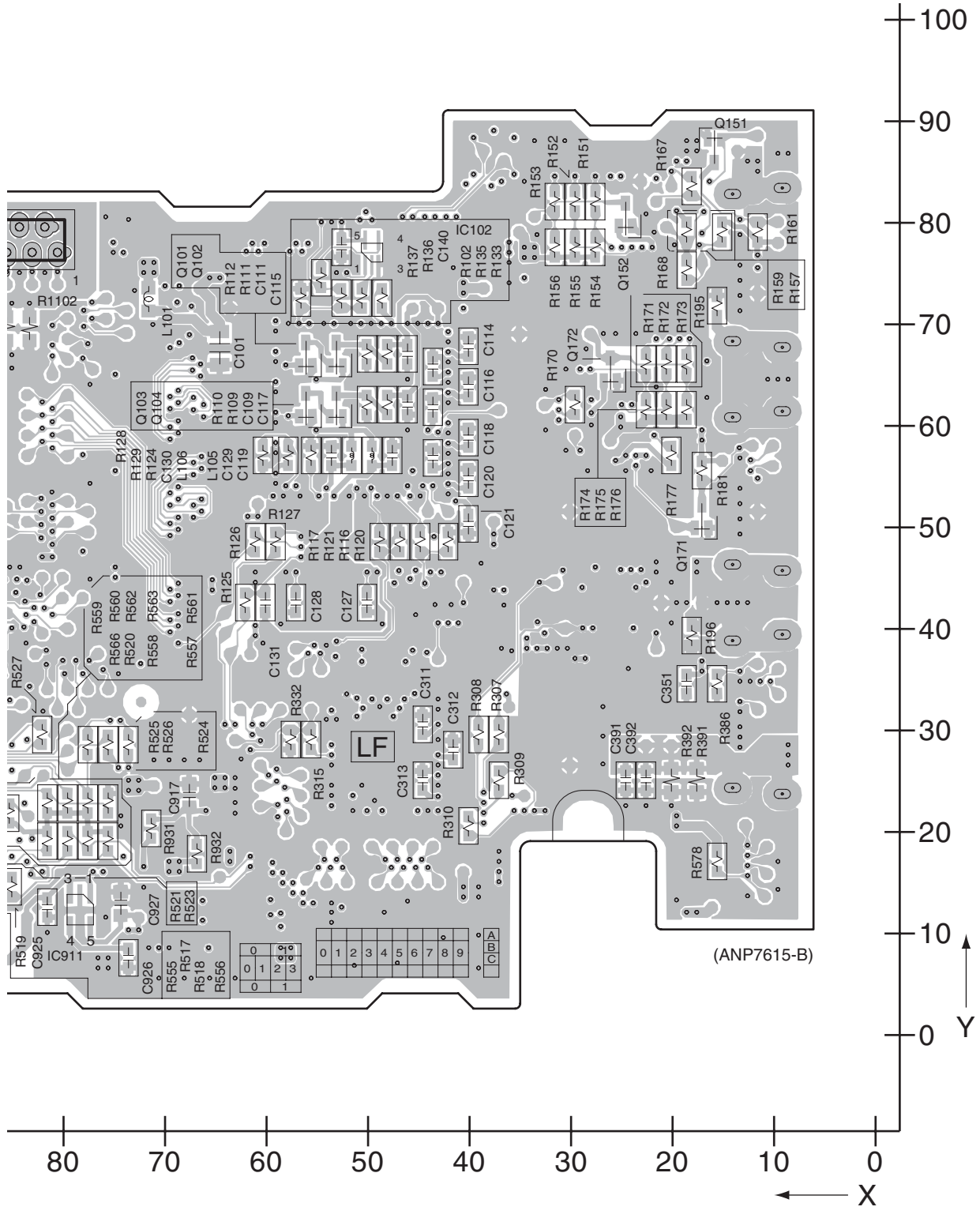

(ANP7615-B)



■

5

■

6

■

7

■

8

■

A

■

B

■

C

■

D

■

E

■

F

■

5

■

6

VSX-LX50

■

7

■

8

■

# 12. PCB PARTS LIST

- NOTES: ● Parts marked by "NSP" are generally unavailable because they are not in our Master Spare Parts List.  
 ● The  $\Delta$  mark found on some component parts indicates the importance of the safety factor of the part. Therefore, when replacing, be sure to use parts of identical designation.  
 ● When ordering resistors, first convert resistance values into code form as shown in the following examples.  
 Ex.1 When there are 2 effective digits (any digit apart from 0), such as 560 ohm and 47k ohm (tolerance is shown by J=5%, and K=10%).
- |              |   |                      |       |     |       |         |      |
|--------------|---|----------------------|-------|-----|-------|---------|------|
| 560 $\Omega$ | → | 56 x 10 <sup>1</sup> | →     | 561 | ..... | RD1/4PU | 561J |
| 47k $\Omega$ | → | 47 x 10 <sup>3</sup> | →     | 473 | ..... | RD1/4PU | 473J |
| 0.5 $\Omega$ | → | R50                  | ..... |     |       | RN2H    | R50K |
| 1 $\Omega$   | → | 1R0                  | ..... |     |       | RS1P    | 1R0K |
- Ex.2 When there are 3 effective digits (such as in high precision metal film resistors).
- |                |   |                       |   |     |       |         |       |
|----------------|---|-----------------------|---|-----|-------|---------|-------|
| 5.62k $\Omega$ | → | 562 x 10 <sup>1</sup> | → | 562 | ..... | RN1/4PC | 5621F |
|----------------|---|-----------------------|---|-----|-------|---------|-------|
- Meaning of the figures and others in the parentheses in the parts list.  
 Example) IC 301 is on the point (face A, 91 of x-axis, and 111 of y-axis) of the corresponding PC board.  
 IC 301 (A, 91, 111) IC NJM2068V

## LIST OF WHOLE PCB ASSEMBLIES

Mark	Symbol and Description	VSX-LX50/ HYXJ5	VSX-91TXH/ KUXJ/CA	VSX-9120TXH-K/ KUXJ
NSP	1..MAIN ASSY	AWK7975	AWK7974	AWK7974
	2..MAIN CONTROL ASSY	AWX8817	AWX8816	AWX8816
	2..AUDIO IN ASSY	AWX8821	AWX8820	AWX8820
	2..12V-REG ASSY	AWX8824	AWX8824	AWX8824
	2..GUARD-C ASSY	AWX8826	AWX8826	AWX8826
	2..GUARD-F ASSY	AWX8825	AWX8825	AWX8825
	1..DSP ASSY	AWX8814	AWX8813	AWX8813
NSP	1..VIDEO ASSY	AWK7984	AWK7983	AWK7983
	2..COMPOSITE ASSY	AWX8842	AWX8841	AWX8841
	2..S-VIDEO ASSY	AWX8845	AWX8844	AWX8844
	2..COMPONENT ASSY	AWX8848	AWX8847	AWX8847
	2..BRIDGE 2 ASSY	AWX8850	AWX8850	AWX8850
NSP	1..COMPLEX ASSY	AWK8015	AWK8014	AWK8014
	2..PRIMARY ASSY	AWX9035	AWX9034	AWX9034
	2..TRANS 1 ASSY	AWX9038	AWX9038	AWX9038
	2..DISPLAY ASSY	AWX8874	AWX8873	AWX8873
	2..VOLUME ASSY	AWX9111	AWX9044	AWX9044
	2..MULTI JOG ASSY	AWX8880	AWX8879	AWX8879
	2..FRONT-IN ASSY	AWX8955	AWX8954	AWX8954
2..HEADPHONE ASSY	AWX9049	AWX9049	AWX9049	
NSP	1..SECONDARY ASSY	AWK7911	AWK7910	AWK7910
	2..PS/SP ASSY	AWX9107	AWX9052	AWX9052
	2..TRANS SIDE ASSY	AWX9056	AWX9056	AWX9056
	2..TRANS 2-1 ASSY	AWX9059	AWX9058	AWX9058
	2..DIODE 1 ASSY	AWX9060	AWX9060	AWX9060
	2..VH TR ASSY	AWX9061	AWX9061	AWX9061
	2..TRANS 2-2 ASSY	AWX9062	AWX9062	AWX9062
	2..LOCAL P-SUPPLY ASSY	AWX9064	AWX9063	AWX9063
	2..IR I/O ASSY	AWX9067	AWX9066	AWX9066
	2..VIDEO CONNECT ASSY	AWX9069	AWX9069	AWX9069
	2..DC/DC ASSY	AWX9015	AWX9015	AWX9015
	2..BRIDGE 1 ASSY	AWX9078	AWX9078	AWX9078
	NSP	1..POWER AMP ASSY	AWK7920	AWK7919
2..POWER AMP-L ASSY		AWX9072	AWX9071	AWX9071
2..POWER AMP-R ASSY		AWX9073	AWX9106	AWX9106
2..POWER AMP IN ASSY		AWX9075	AWX9075	AWX9075
2..POWER PROTECT ASSY		AWX9077	AWX9076	AWX9076
2..POSI 1-L ASSY		AWX9081	AWX9080	AWX9080
2..POSI 2-L ASSY		AWX9082	Not used	Not used
2..POSI 1-R ASSY		AWX9084	AWX9083	AWX9083
1..HDMI & DVC ASSY		AWQ7040	AWQ7040	AWQ7040
1..USB ASSY		AWX8866	Not used	Not used
1..FM/AM TUNER UNIT	AXX7248	AXX7250	AXX7250	

**CONTRAST OF PCB ASSEMBLIES****A AUDIO IN ASSY**

AWX8821 and AWX8820 are constructed the same except for the following:

Mark	Symbol and Description	AWX8821	AWX8820
⚠	IC663 D671 C501, C502, C505-C510 C513-C518, C521-C526 C541-C544, C549-C552  C527, C528, C531-C536 C539, C540, C547, C548 C503, C504, C511, C512, C519, C520 C678 C679  CN516 11p Plug	Not used Not used CCSRCH101J50 CCSRCH101J50 CCSRCH101J50  CCSRCH151J50 CCSRCH151J50 CCSRCH221J50 Not used Not used XKP3065	NJM78M12FA RB501V-40-TRB Not used Not used Not used  Not used Not used Not used CKSRYB103K50 CEAT100M50-TS  Not used

**C MAIN CONTROL ASSY**

AWX8817 and AWX8816 are constructed the same except for the following:

Mark	Symbol and Description	AWX8817	AWX8816
	IC251 IC252 Q102 C251 C253  C254 C255 C256, C257 C260 C261  R124, R126, R127 R130, R132, R199 R131, R171, R259, R260 R136 R152  R156 R187, R188 R189 R251 R252, R253, R254  R255-R258 R261 R383, R384 R9001, R9003, R9005, R9010 J101 Connector Ass'y  CN305 12p Connector CN311 Plug(5p) X251 Crystal Resonator	LC72725KM-TBB Not used Not used CEAT100M50-TS CCSRCH561J50  CEAT101M10-TS CKSRYB102K50 CCSRCH270J50 CKSRYB472K50 Not used  RS1/16S101J Not used Not used RS1/16S222J Not used  Not used RS1/16S0R0J RS1/16S104J RS1/16S473J RS1/16S102J  Not used Not used Not used RS1/16S0R0J Not used Not used	Not used TC74VHC125FTS1-TBB RT1P241M-TLB Not used Not used  Not used Not used Not used Not used CKSRYB104K16  Not used RS1/16S101J RS1/16S104J Not used RS1/16S473J  RS1/16S103J Not used Not used RS1/16S474J Not used  RS1/16S221J RS1/16S274J RS1/16S0R0J Not used PF03GG-Q12  VKN1243 KM200NA5 Not used

**G DSP ASSY**

AWX8814 and AWX8813 are constructed the same except for the following:

Mark	Symbol and Description	AWX8814	AWX8813
	IC501 IC502 IC601 D501, D502 L501, L601	Not used Not used Not used Not used Not used	F2621E-01-TBB AAT4618IGV-0.5-1-TLB TC74VHC157FTS1-TBB UDZS5R6(B)-TRB QTL1013

Mark	Symbol and Description	AWX8814	AWX8813
A	L502	Not used	ATL7002
	C501	Not used	CEVW470M6R3-TRB
	C502, C504, C505, C506, C602	Not used	CKSSYB104K10
	C503	Not used	CKSSYB471K50
	C507	Not used	CEVW101M16-TRB
	C508	Not used	CKSRYB104K16
	C509, C510	Not used	CCSSCH100D50
	C513	Not used	CKSRYB105K16
	R503, R613-R616	RS1/16SS0R0J	Not used
	R518, R601, R610	Not used	RAB4CQ101J
B	R964	Not used	RAB4CQ104J
	R533, R535, R536	Not used	RS1/16SS0R0J
	R504, R506, R516, R523, R524	Not used	RS1/16SS101J
	R525, R526, R528, R605, R608	Not used	RS1/16SS101J
	R505, R507	Not used	RS1/16SS102J
	R531	Not used	RS1/16SS103J
	R511	Not used	RS1/16SS105J
	R514, R515, R517, R519, R520	Not used	RS1/16SS223J
	R521, R532	Not used	RS1/16SS223J
	R527, R529, R604, R606, R607, R609	Not used	RS1/16SS470J
C	R510	Not used	RS1/16SS471J
	CN953 12p Connector	Not used	VKN1416
	CN501 4p Socket	Not used	AKP7201
	JA351 Jack	AKB7131	AKB7173
	X501	Not used	ASS7065

## **H** COMPOSITE ASSY

AWX8842 and AWX8841 are constructed the same except for the following:

Mark	Symbol and Description	AWX8842	AWX8841
D	IC1002	Not used	TC74HC4051AFT-TBB
	IC1151	Not used	M61545FP-TBB
	Q1151	Not used	IMX25
	D1006	Not used	DAN202U-TLB
	D1007	Not used	1SS355-TRB
	D1112	Not used	DAN217U-TLB
	C1003, C1004, C1163	Not used	CKSRYB104K16
	C1015	Not used	CEAT101M10
E	C1023	Not used	CCSRCH181J50
	C1101-C1104	CCSRCH101J50	Not used
	C1151-C1154	Not used	CEAT2R2M50
	C1155, C1156, C1161, C1162	Not used	CCSRCH101J50
	C1157, C1158	Not used	CCSRCH331J50
	C1159	Not used	CKSRYB104K50
	C1160	Not used	CEAT100M50
	C1164	Not used	CKSRYB103K50
	R1005	Not used	RS1/16S750J
	R1053	Not used	RS1/16S0R0J
F	R1151, R1152	Not used	RS1/16S104J
	R1153, R1154	Not used	RS1/16S202J
	R1155, R1156	Not used	RS1/16S103J
	R1157, R1158	Not used	RS1/16S101J
	R1159, R1160, R1164	Not used	RS1/16S471J
	R1163	Not used	RS1/16S473J
	JA1006 Pin Jack(1p)	AKB7175	Not used
	1004 Pin Jack(2p)	Not used	AKB7176
	1005 Pin Jack(2p)	Not used	AKB7181

## I S-VIDEO ASSY

AWX8845 and AWX8844 are constructed the same except for the following:

Mark	Symbol and Description	AWX8845	AWX8844
	IC1301	Not used	SP3232ECY-TBB
	Q1301	Not used	2SC4081(QRS)-TLB
	Q1351	Not used	2SA1576A(RS)-TLB
	Q1352	Not used	RT1N241M-TLB
	Q1353	Not used	2SA1576A(RS)-TLB
	D1302	Not used	1SS355-TRB
	D1351, D1601, D1602	Not used	UDZS5R1(B)-TRB
	D1603-D1606	Not used	UDZS6R2(B)-TRB
	L1351	Not used	ATL7002
	C1304-C1306, C1308, C1352	Not used	CKSRYB104K16
	C1309, C1353, C1311	Not used	CKSRYB103K50
	C1310	Not used	CCSRCH331J50
	C1354	Not used	CKSRYB102K50
	C1355	Not used	CKSRYB472K50
	C1605, C1606	Not used	CEAT470M25
	R1310	RS1/16S103J	Not used
	R1309, R1624, R1629, R1630	Not used	RS1/16S0R0J
	R1301-R1304	Not used	RS1/16S101J
	R1307, R1353, R1354	Not used	RS1/16S103J
	R1351, R1352	Not used	RS1/16S180J
	R1305, R1308	Not used	RS1/16S224J
	R1603, R1604	Not used	RS1/16S331J
	R1355, R1356	Not used	RS1/16S472J
	R1306, R1601, R1602	Not used	RS1/16S474J
	CN1301 9p D-sub Socket	Not used	AKP1213
	CN1302 07p Connector	RKN1048	Not used
	JA1351 Jack	Not used	RKN1004
	JA1601 Socket	Not used	BKP1127
	J1602 Connector Ass'y	Not used	PF05PG-Q15

## K COMPONENT ASSY

AWX8848 and AWX8847 are constructed the same except for the following:

Mark	Symbol and Description	AWX8848	AWX8847
	C1501, C1502, C1521, C1522, C1541	CCSRCH101J50	Not used
	C1542, C1561, C1562	CCSRCH101J50	Not used
	C1507, C1508, C1527, C1528, C1569	CCSRCH271J50	Not used
	C1570, C1571, C1572	CCSRCH271J50	Not used

## L DISPLAY ASSY

AWX8874 and AWX8873 are constructed the same except for the following:

Mark	Symbol and Description	AWX8874	AWX8873
	Q2402	Not used	UMB1N
	Q2409	RT1N431M-TLB	Not used
	D2401	Not used	1SS355-TRB
	D2402	Not used	DAN217U-TLB
	D2415	Not used	DAN202U-TLB
	D2414	SLR343BC4T(JKLM)-TS	Not used
	C2402	Not used	CKSRYB153K50
	R2407	Not used	RS1/16S223J
	R2408, R2410	Not used	RS1/16S103J
	R2409	Not used	RS1/16S392J
	R2414	RS1/16S0R0J	Not used
	R2423	RS1/16S221J	Not used
	R2425, R2426	Not used	RS1/16S0R0J

## P FRONT\_IN ASSY

AWX8955 and AWX8954 are constructed the same except for the following:

Mark	Symbol and Description	AWX8955	AWX8954
	L2752, L2753 C2673 C2753, C2756 C2755 C2757	VTL1169 CKSRYB104K16 CKSRYB104K16 CEAT101M16-TS CCSRCH471J50	Not used CKSRYB104K25 Not used Not used Not used
	R2751, R2752 JA2751 USB Connector CN2652 Connector	RS1/16S0R0J XKP3086 B4B-PH-K-S	Not used Not used Not used

## Q PRIMARY ASSY

AWX9035 and AWX9034 are constructed the same except for the following:

Mark	Symbol and Description	AWX9035	AWX9034
⚠	T2001	ATT7040	ATT7043
⚠	RY2001	ASR7013	ASR7022
⚠	R2001	Not used	RCN1080
	R2002	RD1/4MUF101J	RD1/4MUF220J
⚠	2001 AC Socket 1-p	Not used	AKP1033

## S TRANS 2-1 ASSY

AWX9059 and AWX9058 are constructed the same except for the following:

Mark	Symbol and Description	AWX9059	AWX9058
	D3253	UDZS8R2(B)-TRB	UDZS10(B)-TRB
	D3254	UDZS7R5(B)-TRB	UDZS9R1(B)-TRB
	D3255	UDZS9R1(B)-TRB	UDZS10(B)-TRB
	D3256	UDZS8R2(B)-TRB	UDZS9R1(B)-TRB
	D3263	UDZS13(B)-TRB	UDZS10(B)-TRB
	D3264	UDZS15(B)-TRB	UDZS12(B)-TRB

## W PS/SP ASSY

AWX9107 and AWX9052 are constructed the same except for the following:

Mark	Symbol and Description	AWX9107	AWX9052
	C3101, C3102	ACH7255	ACH7258
	CN3002 Speaker Terminal 6-p	AKE7108	AKE7107
	CN3001 Speaker Terminal 8-p	AKE7119	AKE7118

## Z LOCAL P-SUPPLY ASSY

AWX9064 and AWX9063 are constructed the same except for the following:

Mark	Symbol and Description	AWX9064	AWX9063
⚠	IC3502	AEK7012	Not used
⚠	Q3501	UMD2N-TLB	Not used
⚠	Q3502	2SD1763A(DE)	Not used
	Q3503	DTC124EUA-TLB	Not used
⚠	D3509, D3510	1SR154-400-TRB	Not used
	D3511	UDZS27(B)-TRB	Not used
	C3512	CEAT100M50	Not used
	C3513	CKSRYB102K50	Not used
	C3514	CEAT100M50	Not used
	C3510	CEANP102M16-F	Not used
	C3511	CEAT102M35-F	Not used
	C3515	CEANP470M25	Not used
	R3504	RS1/16S472J	Not used
	R3505	RS1/16S101J	Not used
	R3506	RS1/16S222J	Not used

**AB IR I/O ASSY**

AWX9067 and AWX9066 are constructed the same except for the following:

Mark	Symbol and Description	AWX9067	AWX9066
	D3702	Not used	1SS355-TRB
	L3701	Not used	CTF1473
	L3702	Not used	QTL1013
	L3703	Not used	CTF1473
	L3704	Not used	CTF1385
	C3758	Not used	CKSRYB103K50
	R3701	Not used	RS1/16S0R0J
	R3702	Not used	RS1/16S102J
	R3703, R3755	RS1/16S0R0J	Not used
	JA3701 Connector	Not used	CKS4124
	JA3702 Jack	Not used	RKN1004

**AD POWER AMP-L ASSY**

AWX9072 and AWX9071 are constructed the same except for the following:

Mark	Symbol and Description	AWX9072	AWX9071
NSP	CN5005 Connector	B2B-PH-K-R	Not used

**AE POSI 1-L ASSY**

AWX9081 and AWX9080 are constructed the same except for the following:

Mark	Symbol and Description	AWX9081	AWX9080
⚠	TH4501 Posistor	PTFM04BH222Q2N34B0	PTFM04BC222Q2N34B0

**AG POWER AMP-R ASSY**

AWX9073 and AWX9106 are constructed the same except for the following:

Mark	Symbol and Description	AWX9073	AWX9106
	5002 PCB Binder	VEF1040	Not used

**AH POSI 1-R ASSY**

AWX9084 and AWX9083 are constructed the same except for the following:

Mark	Symbol and Description	AWX9084	AWX9083
⚠	TH4503 Posistor	PTFM04BH222Q2N34B0	PTFM04BC222Q2N34B0

**AJ POWER PROTECT ASSY**

AWX9077 and AWX9076 are constructed the same except for the following:

Mark	Symbol and Description	AWX9077	AWX9076
	Q5703	RT1N241M-TLB	Not used
	Q5706	RT1P241M-TLB	Not used
	D5702	1SS355-TRB	Not used
	C5706	CKSRYB103K50	Not used
	R5704, R5709	Not used	RS1/16S0R0J
	R5705, R5708, R5746	RS1/16S0R0J	Not used
	R5706	RS1/16S822J	Not used
	R5718	RS1/16S104J	Not used
	CN5706 3pin Connector	S3B-EH	Not used

**PCB PARTS LIST FOR VSX-LX50/HYXJ5 UNLESS OTHER WISE NOTED**

Mark No.	Description	Part No.	Mark No.	Description	Part No.
<b>MAIN ASSY (AWK7975)</b>			R 511 (B,302,128)		RS1/16S222J
<b>MISCELLANEOUS</b>			R 512 (B,302,118)		RS1/16S222J
J	663 JUMPER WIRE	D20PDD0605E	R 513 (B,302,142)		RS1/16S331J
			R 514 (B,302,135)		RS1/16S331J
			R 515 (B,302,209)		RS1/16S331J
<b>A AUDIO IN ASSY</b>					
<b>MISCELLANEOUS</b>			R 516 (B,302,202)		RS1/16S331J
IC	501 (A,262,69) 8CH E-VOL	R2S15205FP	R 517 (B,302,222)		RS1/16S331J
IC	701 (A,205,68) OP-AMP IC	BA4560RF	R 518 (B,302,216)		RS1/16S331J
IC	702 (A,220,73) OP-AMP IC	BA4560RF	R 519 (B,302,155)		RS1/16S222J
IC	703 (A,220,56) IC	TC4066BFT	R 520 (B,302,148)		RS1/16S222J
IC	741 (A,177,68) OP-AMP IC	BA4560RF	R 521 (B,302,168)		RS1/16S331J
			R 522 (B,302,161)		RS1/16S331J
IC	761 (A,191,68) OP-AMP IC	BA4560RF	R 523 (B,302,182)		RS1/16S331J
IC	781 (A,163,68) OP-AMP IC	BA4560RF	R 524 (B,302,176)		RS1/16S331J
IC	801 (A,264,170) OP-AMP IC	UPC4570G2	R 525 (B,302,195)		RS1/16S331J
IC	821 (A,264,139) OP-AMP IC	UPC4570G2			
IC	841 (A,264,155) OP-AMP IC	UPC4570G2	R 526 (B,302,189)		RS1/16S331J
			R 527 (B,309,56)		RS1/16S474J
IC	861 (A,264,123) OP-AMP IC	UPC4570G2	R 528 (B,309,51)		RS1/16S474J
Q	661 (A,136,78) TRANSISTOR	2SD1858X	R 529 (B,309,69)		RS1/16S474J
Q	662 (A,136,90) TRANSISTOR	2SB1238X	R 530 (B,309,64)		RS1/16S474J
Q	701 (A,224,50) TRANSISTOR	UMD2N			
D	591 (B,231,52) DIODE	DAN217U	R 531 (B,309,84)		RS1/16S474J
			R 532 (B,309,79)		RS1/16S474J
D	661 (B,39,52) DIODE	1SR154-400	R 533 (B,309,97)		RS1/16S474J
D	662 (B,34,52) DIODE	1SR154-400	R 534 (B,309,92)		RS1/16S474J
D	663 (B,25,52) DIODE	1SR154-400	R 535 (B,309,110)		RS1/16S474J
D	664 (B,30,52) DIODE	1SR154-400			
D	669 (B,127,75) DIODE	UDZS7R5(B)	R 536 (B,309,107)		RS1/16S474J
			R 537 (B,309,128)		RS1/16S474J
D	670 (B,127,87) DIODE	UDZS7R5(B)	R 538 (B,309,118)		RS1/16S474J
J	662 (A,85,59) 3P HOUSING WIRE ASSY	ADX7509	R 539 (B,309,140)		RS1/16S474J
CN	501 (A,258,24) 23P PLUG	XKP3071	R 540 (B,309,134)		RS1/16S474J
CN	507 (A,266,24) CONNECTOR	CKS1730			
CN	509 (A,234,48) 23P PLUG	XKP3071	R 541 (B,309,210)		RS1/16S474J
			R 542 (B,309,205)		RS1/16S474J
CN	511 (A,131,47) CONNECTOR	CKS1730	R 543 (B,309,223)		RS1/16S474J
CN	512 (A,220,24) 23P PLUG	XKP3071	R 544 (B,309,218)		RS1/16S474J
CN	513 (A,98,48) 23P PLUG	XKP3071	R 545 (B,309,154)		RS1/16S474J
CN	516 (A,39,24) 11P PLUG	XKP3065			
CN	520 (A,282,208) 17P SOCKET	XKP3079	R 546 (B,309,149)		RS1/16S474J
			R 547 (B,309,167)		RS1/16S474J
CN	521 (A,317,60) PIN JACK(4P)	AKB7172	R 548 (B,309,162)		RS1/16S474J
CN	522 (A,317,88) PIN JACK(4P)	AKB7172	R 549 (B,309,182)		RS1/16S474J
CN	524 (A,317,158) PIN JACK(4P)	AKB7172	R 550 (B,309,177)		RS1/16S474J
CN	525 (A,317,186) PIN JACK(4P)	AKB7172			
CN	526 (A,317,214) PIN JACK(4P)	AKB7172	R 551 (B,309,195)		RS1/16S474J
			R 552 (B,309,190)		RS1/16S474J
CN	661 (A,26,62) L-PLUG(10P)	KM200NA10L	R 561 (A,246,87)		RS1/16S472J
	501 (A,150,71) PCB BINDER	VEF1040	R 562 (A,244,75)		RS1/16S472J
	523 (A,317,123) PIN JACK(6P)	AKB7182	R 563 (A,244,58)		RS1/16S102J
Y	661 AWG14 BOARD IN	ADX7511			
	664 (A,46,67) 6P CABLE HOLDER	51048-0600	R 564 (A,244,57)		RS1/16S102J
			R 565 (B,268,42)		RS1/16S0R0J
			R 566 (B,275,42)		RS1/16S0R0J
			R 571 (B,256,33)		RS1/16S0R0J
			R 572 (B,234,53)		RS1/16S0R0J
			R 601 (B,222,22)		RS1/16S0R0J
			R 663 (B,133,76)		RS1/16S472J
			R 664 (B,133,88)		RS1/16S472J
			R 665 (B,133,72)		RS1/16S101J
			R 666 (B,133,84)		RS1/16S101J
			R 701 (A,203,61)		RS1/16S473J
			R 702 (A,208,61)		RS1/16S473J
			R 703 (B,204,60)		RS1/16S332J
			R 704 (B,207,60)		RS1/16S332J
<b>RESISTORS</b>					
R	501 (B,303,54)	RS1/16S331J			
R	502 (B,302,43)	RS1/16S331J			
R	503 (B,302,71)	RS1/16S222J			
R	504 (B,302,64)	RS1/16S222J			
R	505 (B,302,84)	RS1/16S331J			
R	506 (B,302,77)	RS1/16S331J			
R	507 (B,302,97)	RS1/16S331J			
R	508 (B,302,91)	RS1/16S331J			
R	509 (B,302,110)	RS1/16S331J			
R	510 (B,302,103)	RS1/16S331J			

5		6		7		8	
<u>Mark No.</u>	<u>Description</u>	<u>Part No.</u>	<u>Mark No.</u>	<u>Description</u>	<u>Part No.</u>		
R 705	(B,202,60)	RS1/16S332J	R 784	(B,165,60)	RS1/16S272J		
R 706	(B,209,60)	RS1/16S332J	R 785	(B,160,60)	RS1/16S272J		
R 707	(B,202,64)	RS1/16S392J	R 786	(B,167,60)	RS1/16S272J		A
R 708	(B,209,64)	RS1/16S392J	R 787	(B,160,64)	RS1/16S272J		
R 709	(B,204,64)	RS1/16S472J	R 788	(B,167,64)	RS1/16S272J		
R 710	(B,207,64)	RS1/16S472J	R 789	(B,162,64)	RS1/16S392J		
R 711	(B,204,68)	RS1/16S272J	R 790	(B,165,64)	RS1/16S392J		
R 712	(B,207,68)	RS1/16S272J	R 791	(B,162,68)	RS1/16S122J		
R 713	(B,202,72)	RS1/16S331J	R 792	(B,165,68)	RS1/16S122J		
R 714	(B,209,72)	RS1/16S331J	R 793	(B,160,72)	RS1/16S221J		
R 715	(B,204,72)	RS1/16S474J	R 794	(B,167,72)	RS1/16S221J		
R 716	(B,207,72)	RS1/16S474J	R 797	(B,158,79)	RS1/16S101J		
R 719	(B,223,80)	RS1/16S0R0J	R 798	(B,169,79)	RS1/16S101J		
R 720	(B,216,80)	RS1/16S0R0J	R 801	(B,262,165)	RS1/16S223J		B
R 721	(B,223,77)	RS1/16S472J	R 802	(B,262,176)	RS1/16S223J		
R 722	(B,216,77)	RS1/16S472J	R 805	(A,266,165)	RS1/16S682J		
R 723	(A,226,70)	RS1/16S472J	R 806	(A,266,175)	RS1/16S682J		
R 724	(A,213,70)	RS1/16S472J	R 807	(A,269,168)	RS1/16S331J		
R 725	(A,226,74)	RS1/16S122J	R 808	(A,269,173)	RS1/16S331J		
R 726	(A,213,74)	RS1/16S122J	R 811	(A,263,165)	RS1/16S153J		
R 727	(B,223,73)	RS1/16S392J	R 812	(A,263,175)	RS1/16S153J		
R 728	(B,216,73)	RS1/16S392J	R 815	(B,262,194)	RS1/16S104J		
R 731	(B,225,66)	RS1/16S101J	R 816	(B,262,186)	RS1/16S104J		
R 732	(B,214,66)	RS1/16S101J	R 821	(B,262,134)	RS1/16S223J		
R 733	(A,226,48)	RS1/16S473J	R 822	(B,262,144)	RS1/16S223J		C
R 741	(A,175,61)	RS1/16S473J	R 825	(A,266,134)	RS1/16S682J		
R 742	(A,180,61)	RS1/16S473J	R 826	(A,266,144)	RS1/16S682J		
R 743	(B,176,60)	RS1/16S272J	R 827	(A,269,137)	RS1/16S331J		
R 744	(B,179,60)	RS1/16S332J	R 828	(A,269,142)	RS1/16S331J		
R 745	(B,174,60)	RS1/16S272J	R 831	(A,263,134)	RS1/16S153J		
R 746	(B,181,60)	RS1/16S562J	R 832	(A,263,144)	RS1/16S153J		
R 747	(B,174,64)	RS1/16S272J	R 835	(B,275,194)	RS1/16S104J		
R 748	(B,181,64)	RS1/16S393J	R 836	(B,275,186)	RS1/16S104J		
R 749	(B,176,64)	RS1/16S392J	R 841	(B,262,149)	RS1/16S223J		
R 750	(B,179,64)	RS1/16S182J	R 842	(B,262,160)	RS1/16S223J		
R 751	(B,176,68)	RS1/16S122J	R 845	(A,266,150)	RS1/16S682J		D
R 752	(B,179,68)	RS1/16S362J	R 846	(A,266,160)	RS1/16S682J		
R 753	(B,174,72)	RS1/16S221J	R 847	(A,269,152)	RS1/16S331J		
R 754	(B,181,72)	RS1/16S121J	R 848	(A,269,157)	RS1/16S331J		
R 757	(B,172,79)	RS1/16S101J	R 851	(A,263,150)	RS1/16S153J		
R 758	(B,183,79)	RS1/16S101J	R 852	(A,263,160)	RS1/16S153J		
R 761	(A,189,61)	RS1/16S473J	R 855	(B,269,194)	RS1/16S104J		
R 762	(A,194,61)	RS1/16S473J	R 856	(B,269,186)	RS1/16S104J		
R 763	(B,190,60)	RS1/16S272J	R 861	(B,262,118)	RS1/16S223J		
R 764	(B,193,60)	RS1/16S272J	R 862	(B,262,129)	RS1/16S223J		
R 765	(B,188,60)	RS1/16S272J	R 865	(A,266,118)	RS1/16S682J		
R 766	(B,195,60)	RS1/16S272J	R 866	(A,266,128)	RS1/16S682J		E
R 767	(B,188,64)	RS1/16S272J	R 867	(A,269,121)	RS1/16S331J		
R 768	(B,195,64)	RS1/16S272J	R 868	(A,269,126)	RS1/16S331J		
R 769	(B,190,64)	RS1/16S392J	R 871	(A,263,118)	RS1/16S153J		
R 770	(B,193,64)	RS1/16S392J	R 872	(A,263,128)	RS1/16S153J		
R 771	(B,190,68)	RS1/16S122J	R 875	(B,282,194)	RS1/16S104J		
R 772	(B,193,68)	RS1/16S122J	R 876	(B,282,186)	RS1/16S104J		
R 773	(B,188,72)	RS1/16S221J	R 883	(A,253,116)	RS1/16S0R0J		
R 774	(B,195,72)	RS1/16S221J					
R 777	(B,186,79)	RS1/16S101J					
R 778	(B,197,79)	RS1/16S101J					
R 781	(A,161,61)	RS1/16S473J					
R 782	(A,166,61)	RS1/16S473J					
R 783	(B,162,60)	RS1/16S272J					
			<b>CAPACITORS</b>				
			C 501	(B,307,56)	CCSRCH101J50		F
			C 502	(B,307,51)	CCSRCH101J50		
			C 503	(B,307,69)	CCSRCH221J50		

	<u>Mark No.</u>	<u>Description</u>	<u>Part No.</u>	<u>Mark No.</u>	<u>Description</u>	<u>Part No.</u>
	C 504 (B,307,64)		CCSRCH221J50	C 570 (A,293,201)	ELECT. CAPACITOR	CEAT470M25
	C 505 (B,307,84)		CCSRCH101J50	C 571 (A,300,157)		CEAT100M50
A	C 506 (B,307,79)		CCSRCH101J50	C 572 (A,300,148)		CEAT100M50
	C 507 (B,307,97)		CCSRCH101J50	C 573 (A,300,170)	ELECT. CAPACITOR	CEAT470M25
	C 508 (B,307,92)		CCSRCH101J50	C 574 (A,300,161)	ELECT. CAPACITOR	CEAT470M25
	C 509 (B,307,110)		CCSRCH101J50	C 575 (A,300,184)	ELECT. CAPACITOR	CEAT470M25
	C 510 (B,307,107)		CCSRCH101J50	C 576 (A,300,175)	ELECT. CAPACITOR	CEAT470M25
	C 511 (B,307,128)		CCSRCH221J50	C 577 (A,300,197)	ELECT. CAPACITOR	CEAT470M25
	C 512 (B,307,118)		CCSRCH221J50	C 578 (A,300,188)	ELECT. CAPACITOR	CEAT470M25
	C 513 (B,307,140)		CCSRCH101J50	C 579 (A,270,87)		CEAT101M16
	C 514 (B,307,134)		CCSRCH101J50	C 580 (A,268,95)		CEAT101M16
	C 515 (B,307,210)		CCSRCH101J50	C 581 (A,264,87)		CEAT101M16
B	C 516 (B,307,205)		CCSRCH101J50	C 582 (A,262,95)		CEAT101M16
	C 517 (B,307,223)		CCSRCH101J50	C 583 (A,258,87)		CEAT101M16
	C 518 (B,307,218)		CCSRCH101J50	C 584 (A,256,95)		CEAT101M16
	C 519 (B,307,154)		CCSRCH221J50	C 585 (A,252,87)		CEAT101M16
	C 520 (B,307,149)		CCSRCH221J50	C 586 (A,250,95)		CEAT101M16
	C 521 (B,307,167)		CCSRCH101J50	C 587 (A,247,84)		CKSRYP473K50
	C 522 (B,307,162)		CCSRCH101J50	C 588 (A,246,84)		CKSRYP154K10
	C 523 (B,307,182)		CCSRCH101J50	C 589 (A,244,84)		CKSRYP223K50
	C 524 (B,307,177)		CCSRCH101J50	C 590 (A,247,76)		CKSRYP473K50
	C 525 (B,307,195)		CCSRCH101J50	C 591 (A,247,74)		CKSRYP154K10
C	C 526 (B,307,190)		CCSRCH101J50	C 592 (A,244,73)		CKSRYP223K50
	C 527 (B,297,49)		CCSRCH151J50	C 593 (A,248,59)		CCSRCH101J50
	C 528 (B,298,44)		CCSRCH151J50	C 594 (A,247,59)		CCSRCH101J50
	C 531 (B,297,83)		CCSRCH151J50	C 595 (A,247,79)		CKSRYP103K50
	C 532 (B,298,79)		CCSRCH151J50	C 596 (A,247,78)		CKSRYP103K50
	C 533 (B,297,96)		CCSRCH151J50	C 599 (A,269,35)		CEJQ100M25
	C 534 (B,298,92)		CCSRCH151J50	C 600 (A,274,35)		CEJQ100M25
	C 535 (B,297,109)		CCSRCH151J50	C 641 (B,309,114)		CKSRYP103K50
	C 536 (B,298,105)		CCSRCH151J50	C 642 (B,309,88)		CKSRYP103K50
	C 539 (B,297,141)		CCSRCH151J50	C 643 (B,309,214)		CKSRYP103K50
D	C 540 (B,298,137)		CCSRCH151J50	C 644 (B,309,158)		CKSRYP103K50
	C 541 (B,297,209)		CCSRCH101J50	C 645 (B,309,186)		CKSRYP103K50
	C 542 (B,298,203)		CCSRCH101J50	C 661 (A,50,48)	ELECT. CAPACITOR	CEAT222M25
	C 543 (B,300,222)		CCSRCH101J50	C 662 (A,64,48)	ELECT. CAPACITOR	CEAT222M25
	C 544 (B,300,216)		CCSRCH101J50	C 673 (A,130,76)		CEAT2R2M50
	C 547 (B,297,167)		CCSRCH151J50	C 674 (A,130,86)		CEAT2R2M50
	C 548 (B,298,163)		CCSRCH151J50	C 675 (A,143,76)		CEAT100M50
	C 549 (B,297,182)		CCSRCH101J50	C 676 (A,143,86)		CEAT100M50
	C 550 (B,298,177)		CCSRCH101J50	C 701 (A,202,53)		CEAT2R2M50
	C 551 (B,297,194)		CCSRCH101J50	C 702 (A,208,53)		CEAT2R2M50
E	C 552 (B,297,190)		CCSRCH101J50	C 703 (A,203,62)		CCSRCH471J50
	C 553 (A,300,51) ELECT. CAPACITOR	CEAT470M25		C 704 (A,208,62)		CCSRCH471J50
	C 554 (A,300,42) ELECT. CAPACITOR	CEAT470M25		C 705 (A,203,64)		CCSRCH331J50
	C 555 (A,300,73)	CEAT100M50		C 706 (A,208,64)		CCSRCH331J50
	C 556 (A,300,64)	CEAT100M50		C 707 (B,202,68)		CCSRCH391J50
	C 557 (A,300,86) ELECT. CAPACITOR	CEAT470M25		C 708 (B,209,68)		CCSRCH391J50
	C 558 (A,300,77) ELECT. CAPACITOR	CEAT470M25		C 709 (A,202,76)		CEAT100M50
	C 559 (A,300,99) ELECT. CAPACITOR	CEAT470M25		C 710 (A,209,76)		CEAT100M50
	C 560 (A,300,90) ELECT. CAPACITOR	CEAT470M25		C 713 (A,223,69)		CEAT100M50
	C 561 (A,300,112) ELECT. CAPACITOR	CEAT470M25		C 714 (A,216,69)		CEAT100M50
	C 562 (A,300,103) ELECT. CAPACITOR	CEAT470M25		C 717 (A,208,72)		CKSRYP103K50
	C 563 (A,300,131)	CEAT100M50		C 718 (A,203,72)		CKSRYP103K50
	C 564 (A,300,120)	CEAT100M50		C 719 (A,217,77)		CKSRYP104K50
	C 565 (A,300,144) ELECT. CAPACITOR	CEAT470M25		C 720 (A,222,77)		CKSRYP104K50
F	C 566 (A,300,135) ELECT. CAPACITOR	CEAT470M25		C 721 (A,224,53)		CKSRYP103K50
	C 567 (A,300,210) ELECT. CAPACITOR	CEAT470M25		C 722 (A,215,56)		CKSRYP103K50
	C 568 (A,300,201) ELECT. CAPACITOR	CEAT470M25		C 741 (A,174,53)		CEAT2R2M50
	C 569 (A,293,210) ELECT. CAPACITOR	CEAT470M25		C 742 (A,180,53)		CEAT2R2M50

Mark No.	Description	Part No.	Mark No.	Description	Part No.
C 743 (A,175,62)		CCSRCH331J50	C 847 (A,266,192)	ELECT. CAPACITOR	CEAT470M25
C 744 (A,180,62)		CKSRYPB223K50	C 848 (A,266,185)	ELECT. CAPACITOR	CEAT470M25
C 745 (A,175,64)		CCSRCH331J50	C 849 (A,260,152)		CKSRYPB103K50
C 746 (A,180,64)		CKSRYPB103K50	C 850 (A,260,157)		CKSRYPB103K50
C 747 (B,174,68)		CCSRCH471J50	C 861 (A,271,108)		CEAT4R7M50
C 748 (B,181,68)		CKSRYPB682K50	C 862 (A,271,101)		CEAT4R7M50
C 749 (A,174,76)		CEAT100M50	C 865 (A,263,117)		CCSRCH101J50
C 750 (A,181,76)		CEAT100M50	C 866 (A,263,129)		CCSRCH101J50
C 751 (B,176,79)		CKSRYPB472K50	C 867 (A,279,192)	ELECT. CAPACITOR	CEAT470M25
C 752 (B,179,79)		CKSRYPB472K50	C 868 (A,279,185)	ELECT. CAPACITOR	CEAT470M25
C 753 (A,180,72)		CKSRYPB103K50	C 869 (A,260,121)		CKSRYPB103K50
C 754 (A,175,72)		CKSRYPB103K50	C 870 (A,260,126)		CKSRYPB103K50
C 761 (A,188,53)		CEAT2R2M50	<b>B 12V-REG ASSY</b> <b>MISCELLANEOUS</b> ⚠ IC 661 (A,12,90) REGULATOR IC NJM78M12FA ⚠ IC 662 (A,39,90) REGULATOR IC NJM79M12FA D 665 (B,28,90) CHIP DIODE RB501V-40 D 666 (B,56,88) CHIP DIODE RB501V-40 663 (A,46,77) 6P CABLE HOLDER 51048-0600		
C 762 (A,194,53)		CEAT2R2M50			
C 763 (A,189,62)		CCSRCH331J50			
C 764 (A,194,62)		CCSRCH331J50			
C 765 (A,189,64)		CCSRCH331J50			
C 766 (A,194,64)		CCSRCH331J50			
C 767 (B,188,68)		CCSRCH471J50			
C 768 (B,195,68)		CCSRCH471J50			
C 769 (A,188,76)		CEAT100M50			
C 770 (A,195,76)		CEAT100M50			
C 771 (B,190,79)		CKSRYPB472K50	<b>CAPACITORS</b> C 667 (B,11,86) CKSRYPB103K50 C 668 (B,39,86) CKSRYPB103K50 C 669 (A,25,92) CEAT221M25 C 670 (A,52,92) CEAT221M25		
C 772 (B,193,79)		CKSRYPB472K50			
C 773 (A,194,72)		CKSRYPB103K50			
C 774 (A,189,72)		CKSRYPB103K50			
C 781 (A,160,53)		CEAT2R2M50			
C 782 (A,166,53)		CEAT2R2M50			
C 783 (A,161,62)		CCSRCH331J50			
C 784 (A,166,62)		CCSRCH331J50			
C 785 (A,161,64)		CCSRCH331J50			
C 786 (A,166,64)		CCSRCH331J50			
C 787 (B,160,68)		CCSRCH471J50	<b>MISCELLANEOUS</b> IC 101 (A,152,186) CPU PEG378A8 IC 103 (A,114,172) PORT EXPANDER IC BU4094BCFV IC 104 (A,127,190) RESET IC BU4842F IC 106 (A,126,200) IC TC74VHCT08AFTS1 IC 107 (A,101,131) IC TC74VHCT125AFTS1 IC 108 (A,99,165) OCTAL BUS BUFFER IC TC74VHCT244AFTS1 IC 109 (A,123,174) LOGIC IC TC74VHCT32AFT IC 251 (A,110,192) RDS DECODER IC LC72725KM IC 253 (A,178,185) EEPROM BR24L16FV-W IC 301 (A,157,130) CPU PEG117A IC 302 (A,184,132) FLASH ROM AYW7168 IC 304 (A,95,113) IC TC74VHCT125AFTS1 IC 305 (A,130,139) IC TC74VHC02FTS1 IC 306 (A,94,131) IC TC74VHC125FTS1 IC 307 (A,160,210) IC TC74VHC08FTS1 IC 308 (A,114,132) IC TC74LCX244FTS1 ⚠ IC 310 (A,198,141) IC NJM2391DL1-33 Q 101 (B,105,182) DIGITAL TR(SC-70) RT1N431M Q 103 (B,137,182) CHIP TR(DUAL) RN2901 Q 104 (A,120,194) CHIP TR (PNP X 2) UMB1N Q 105 (B,189,204) CHIP TR (PNP X 2) UMB1N Q 106 (B,190,196) CHIP TR (PNP X 2) UMB1N Q 107 (B,93,148) TRANSISTOR RT1N241M Q 108 (B,94,142) CHIP TR (PNP X 2) UMB1N Q 109 (A,98,179) DIGITAL TR(SC-70) RT1P241M Q 110 (A,104,179) DIGITAL TR(SC-70) RT1P241M Q 111 (B,102,174) TRANSISTOR 2SA1576A Q 301 (B,215,147) TRANSISTOR 2SA1036K Q 302 (B,212,137) TRANSISTOR RT1N241M D 101 (B,137,176) DIODE DAN202U		
C 788 (B,167,68)		CCSRCH471J50			
C 789 (A,160,76)		CEAT100M50			
C 790 (A,167,76)		CEAT100M50			
C 791 (B,162,79)		CKSRYPB472K50			
C 792 (B,165,79)		CKSRYPB472K50			
C 793 (A,166,72)		CKSRYPB103K50			
C 794 (A,161,72)		CKSRYPB103K50			
C 801 (A,253,108)		CEAT4R7M50			
C 802 (A,253,101)		CEAT4R7M50			
C 805 (A,263,164)		CCSRCH101J50	<b>MISCELLANEOUS</b> Q 109 (A,98,179) DIGITAL TR(SC-70) RT1P241M Q 110 (A,104,179) DIGITAL TR(SC-70) RT1P241M Q 111 (B,102,174) TRANSISTOR 2SA1576A Q 301 (B,215,147) TRANSISTOR 2SA1036K Q 302 (B,212,137) TRANSISTOR RT1N241M D 101 (B,137,176) DIODE DAN202U		
C 806 (A,263,176)		CCSRCH101J50			
C 807 (A,260,192)	ELECT. CAPACITOR	CEAT470M25			
C 808 (A,260,185)	ELECT. CAPACITOR	CEAT470M25			
C 809 (A,260,168)		CKSRYPB103K50			
C 810 (A,260,173)		CKSRYPB103K50			
C 821 (A,265,108)		CEAT4R7M50			
C 822 (A,265,101)		CEAT4R7M50			
C 825 (A,263,133)		CCSRCH101J50			
C 826 (A,263,145)		CCSRCH101J50			
C 827 (A,273,192)	ELECT. CAPACITOR	CEAT470M25	<b>MISCELLANEOUS</b> Q 105 (B,189,204) CHIP TR (PNP X 2) UMB1N Q 106 (B,190,196) CHIP TR (PNP X 2) UMB1N Q 107 (B,93,148) TRANSISTOR RT1N241M Q 108 (B,94,142) CHIP TR (PNP X 2) UMB1N Q 109 (A,98,179) DIGITAL TR(SC-70) RT1P241M Q 110 (A,104,179) DIGITAL TR(SC-70) RT1P241M Q 111 (B,102,174) TRANSISTOR 2SA1576A Q 301 (B,215,147) TRANSISTOR 2SA1036K Q 302 (B,212,137) TRANSISTOR RT1N241M D 101 (B,137,176) DIODE DAN202U		
C 828 (A,273,185)	ELECT. CAPACITOR	CEAT470M25			
C 829 (A,260,137)		CKSRYPB103K50			
C 830 (A,260,142)		CKSRYPB103K50			
C 841 (A,259,108)		CEAT4R7M50			
C 842 (A,259,101)		CEAT4R7M50			
C 845 (A,263,148)		CCSRCH101J50			
C 846 (A,263,161)		CCSRCH101J50			

<u>Mark No.</u>	<u>Description</u>	<u>Part No.</u>	<u>Mark No.</u>	<u>Description</u>	<u>Part No.</u>
			R 110 (A,135,190)		RS1/16S101J
D	102 (A,203,194) DIODE	DAN202U			
D	103 (A,189,188) DIODE	1SS355	R 111 (A,134,195)		RS1/16S104J
A	D 104 (B,186,185) DIODE	DAP202U	R 112 (A,134,193)		RS1/16S101J
D	105 (B,186,189) DIODE	DAN202U	R 113 (A,139,181)		RS1/16S101J
D	106 (B,189,212) DIODE	UDZS5R1(B)	R 114 (A,133,182)		RS1/16S101J
			R 115 (B,145,182)		RS1/16S101J
D	107 (A,117,193) DIODE	DAN202U			
D	108 (A,200,193) DIODE	RB520S-30	R 116 (B,111,180)		RS1/16S473J
D	114 (B,101,144) DIODE	1SS355	R 117 (A,137,193)		RS1/16S103J
D	291 (A,30,137) DIODE	1SS355	R 118 (B,150,188)		RS1/16S512J
D	301 (B,214,142) DIODE	DAN202U	R 120 (A,132,188)		RS1/16S101J
			R 121 (A,130,190)		RS1/16S104J
D	302 (A,190,119) CHIP DIODE	RB501V-40			
L	101 (B,194,178) CHIP SOLID INDUCTOR	ATL7002	R 123 (B,145,187)		RS1/16S473J
L	102 (B,200,205) CHIP SOLID INDUCTOR	ATL7002	R 124 (A,138,183)		RS1/16S101J
B	L 281 (B,31,202) CHIP SOLID INDUCTOR	QTL1013	R 125 (A,127,184)		RS1/16S101J
L	291 (A,26,138) INDUCTOR	CTF1473	R 126 (A,133,180)		RS1/16S101J
			R 127 (A,133,179)		RS1/16S101J
L	292 (A,26,137) INDUCTOR	CTF1473			
L	293 (A,26,135) INDUCTOR	CTF1473	R 128 (B,107,183)		RS1/16S222J
L	294 (A,26,134) INDUCTOR	CTF1473	R 129 (B,105,174)		RS1/16S222J
L	295 (A,29,144) INDUCTOR	CTF1473	R 133 (A,130,184)		RS1/16S104J
L	301 (A,191,152) CHIP SOLID INDUCTOR	QTL1013	R 134 (B,155,164)		RS1/16S104J
			R 136 (B,152,174)		RS1/16S222J
L	381 (B,74,189) CHIP SOLID INDUCTOR	QTL1013			
JA	281 (A,17,170) OPT. LINK IN	AKS7001	R 137 (B,142,160)		RS1/16S474J
JA	282 (A,17,183) OPT. LINK IN	AKS7001	R 138 (B,154,179)		RS1/16S104J
JA	283 (A,17,197) OPT. LINK IN	AKS7001	R 140 (A,144,176)		RS1/16S472J
C	JA 284 (A,17,210) OPT. LINK OUT	AKS7002	R 141 (B,138,164)		RS1/16S101J
			R 142 (A,163,173)		RS1/16S104J
JA	291 (A,9,131) MINI JACK(4P) /W SW	XKN3015			
JA	292 (A,11,143) JACK REMOCON JACK	RKN1004	R 145 (A,167,184)		RS1/16S101J
KN	281 (A,13,153) SCREW PLATE	VNE1948	R 151 (A,142,204)		RS1/16S473J
X	101 (A,134,187) CERAMIC RESONATOR	XSS3004	R 153 (A,141,204)		RS1/16S473J
X	251 (A,107,201) CRYSTAL RESONATOR	ASS7004	R 155 (A,148,208)		RS1/16S222J
			R 157 (B,179,202)		RS1/16S104J
X	301 (A,144,131) CERAMIC RESONATOR	XSS3004			
CN	101 (A,208,215) CONNECTOR	CKS3394	R 160 (A,136,201)		RS1/16S101J
CN	102 (A,223,129) 9P JUMPER CONNECTOR	52147-0910	R 161 (B,200,201)		RS1/16S0R0J
CN	103 (A,197,187) CONNECTOR	CKS3384	R 162 (B,195,213)		RS1/16S223J
CN	104 (A,60,177) 11P PLUG	XKP3065	R 164 (B,181,184)		RS1/16S105J
D			R 166 (B,188,185)		RS1/16S105J
CN	106 (A,111,212) 23P SOCKET	XKP3082			
CN	107 (A,31,177) 13P PLUG	XKP3066	R 169 (A,125,180)		RS1/16S473J
CN	108 (A,29,153) 13P PLUG	XKP3066	R 170 (A,115,167)		RS1/16S473J
CN	109 (A,53,153) 15P PLUG	XKP3067	R 172 (A,112,167)		RS1/16S561J
CN	110 (A,56,130) 11P PLUG	XKP3065	R 178 (B,106,189)		RS1/16S470J
			R 180 (A,216,120)		RAB4C473J
CN	111 (A,28,130) 13P PLUG	XKP3066			
CN	112 (A,64,102) 23P SOCKET	XKP3082	R 181 (A,105,132)		RS1/16S101J
CN	113 (A,94,180) CONNECTOR	CKS3382	R 182 (A,102,137)		RS1/16S182J
CN	281 (A,33,209) 23P PLUG	XKP3071	R 183 (A,101,137)		RS1/16S104J
CN	301 (A,170,98) PLUG	CKS1764	R 184 (A,99,137)		RS1/16S104J
			R 185 (A,101,122)		RS1/16S101J
E	CN302 (A,199,102) 23P SOCKET	XKP3082			
	102 (A,218,163) PCB BINDER	VEF1040	R 186 (A,96,125)		RS1/16S104J
	101 (A,218,170) PCB BINDER	VEF1040	R 187 (A,103,125)		RS1/16S0R0J
			R 188 (A,122,180)		RS1/16S0R0J
			R 189 (A,96,171)		RS1/16S104J
			R 190 (A,98,171)		RS1/16S104J
<b>RESISTORS</b>					
R	101 (A,138,195)	RAB4C101J			
R	102 (A,138,190)	RS1/16S101J	R 191 (A,101,171)		RS1/16S104J
R	103 (A,132,168)	RAB4C101J	R 192 (A,100,171)		RS1/16S104J
R	104 (A,138,174)	RAB4C101J	R 193 (A,91,125)		RS1/16S104J
R	105 (A,146,170)	RAB4C101J	R 194 (A,117,179)		RS1/16S101J
			R 251 (A,116,198)		RS1/16S473J
F	R 106 (A,151,170)	RAB4C101J			
R	107 (A,165,178)	RAB4C101J	R 252 (A,104,195)		RS1/16S102J
R	108 (A,168,181)	RAB4C101J	R 253 (A,106,184)		RS1/16S102J
R	109 (A,152,208)	RAB4C101J	R 254 (A,106,186)		RS1/16S102J
			R 262 (A,174,182)		RS1/16S472J

5	6	
<u>Mark No.</u>	<u>Description</u>	<u>Part No.</u>
R 263 (A,175,182)	RS1/16S103J	
R 264 (A,172,185)	RS1/16S471J	
R 265 (A,172,186)	RS1/16S471J	
R 281 (B,24,170)	RS1/16S101J	
R 282 (B,23,183)	RS1/16S101J	
R 283 (B,24,197)	RS1/16S101J	
R 301 (A,145,137)	RAB4C101J	
R 302 (A,135,134)	RAB4C101J	
R 305 (A,142,121)	RAB4C101J	
R 306 (B,158,128)	RS1/16S101J	
R 307 (A,156,142)	RAB4C101J	
R 308 (A,146,142)	RAB4C101J	
R 309 (A,153,119)	RS1/16S101J	
R 310 (A,139,130)	RS1/16S473J	
R 311 (B,153,139)	RS1/16S472J	
R 312 (A,140,140)	RS1/16S473J	
R 313 (A,135,144)	RS1/16S101J	
R 314 (A,138,138)	RS1/16S101J	
R 315 (A,125,135)	RS1/16S101J	
R 316 (A,137,140)	RS1/16S473J	
R 317 (B,147,134)	RS1/16S473J	
R 318 (B,147,113)	RS1/16S473J	
R 322 (B,156,129)	RS1/16S101J	
R 323 (B,160,128)	RS1/16S101J	
R 324 (B,168,114)	RS1/16S101J	
R 325 (B,163,115)	RS1/16S473J	
R 326 (B,161,119)	RS1/16S473J	
R 327 (B,166,118)	RS1/16S473J	
R 328 (A,164,117)	RS1/16S101J	
R 329 (A,166,117)	RS1/16S101J	
R 330 (A,165,120)	RS1/16S101J	
R 334 (B,158,140)	RS1/16S473J	
R 335 (B,163,129)	RS1/16S101J	
R 336 (B,151,137)	RS1/16S101J	
R 337 (B,147,136)	RS1/16S473J	
R 340 (B,180,142)	RS1/16S473J	
R 344 (B,122,157)	RS1/16S104J	
R 345 (A,125,167)	RS1/16S104J	
R 346 (A,100,116)	RS1/16S101J	
R 347 (B,211,147)	RS1/16S473J	
R 348 (B,212,143)	RS1/16S222J	
R 349 (B,110,132)	RS1/16S104J	
R 350 (B,104,136)	RS1/16S104J	
R 351 (B,112,132)	RS1/16S104J	
R 352 (B,108,146)	RS1/16S104J	
R 353 (A,111,125)	RS1/16S104J	
R 354 (A,110,125)	RS1/16S104J	
R 355 (B,115,129)	RS1/16S104J	
R 357 (B,90,139)	RS1/16S104J	
R 361 (B,162,113)	RS1/16S331J	
R 362 (B,151,113)	RS1/16S331J	
R 363 (B,141,104)	RS1/16S331J	
R 364 (B,171,115)	RS1/16S331J	
R 385 (B,92,107)	RS1/16S0R0J	
R 9001(A,227,111)	RS1/16S0R0J	
R 9003(A,222,115)	RS1/16S0R0J	
R 9005(A,221,117)	RS1/16S0R0J	
R 9010(A,219,114)	RS1/16S0R0J	

7	8	
<u>Mark No.</u>	<u>Description</u>	<u>Part No.</u>
<b>CAPACITORS</b>		
C 101 (B,195,174)	ELECTR.CAPACITOR	CKSRYB103K50
C 102 (A,197,176)		CEAT102M10
C 103 (B,192,177)		CKSRYB103K50
C 104 (A,147,197)		CKSRYB104K16
C 106 (A,124,192)		CKSRYB105K16
C 108 (A,137,186)		CKSRYB104K16
C 110 (B,148,180)		CKSRYB472K50
C 113 (A,165,185)		CKSRYB104K16
C 118 (A,110,176)		CKSRYB104K16
C 119 (A,185,210)		CEAT100M50
C 120 (B,184,184)		CKSRYB473K25
C 121 (B,191,185)		CKSRYB473K25
C 125 (A,100,188)		CEAT471M6R3
C 127 (A,122,202)		CKSRYB104K16
C 128 (A,97,131)		CKSRYB104K16
C 129 (A,94,166)		CKSRYB104K16
C 130 (A,120,174)		CKSRYB104K16
C 139 (A,110,169)		CCSRCH561J50
C 251 (A,111,182)		CEAT100M50
C 253 (A,114,187)		CCSRCH561J50
C 254 (A,118,205)		CEAT101M10
C 255 (A,112,197)		CKSRYB102K50
C 256 (B,112,204)		CCSRCH270J50
C 257 (B,109,204)		CCSRCH270J50
C 260 (A,109,185)		CKSRYB472K50
C 262 (A,178,182)		CKSRYB103K50
C 281 (B,23,175)		CKSRYB104K16
C 282 (B,23,187)		CKSRYB104K16
C 283 (B,22,203)		CKSRYB104K16
C 284 (B,22,211)		CKSRYB104K16
C 285 (A,31,198)		CEAT101M10
C 293 (B,24,159)		CKSRYB104K16
C 301 (A,208,143)	ELECTR.CAPACITOR	CEAT102M10
C 302 (B,204,144)		CKSRYB104K16
C 304 (A,199,131)		CEAT331M10
C 305 (A,142,128)		CKSRYB104K16
C 307 (A,172,130)		CKSRYB104K16
C 309 (A,152,142)		CKSRYB104K16
C 311 (A,184,145)		CKSRYB104K16
C 315 (A,92,113)		CKSRYB104K16
C 316 (A,126,140)		CKSRYB104K16
C 317 (A,90,132)		CKSRYB104K16
C 318 (A,164,209)		CKSRYB104K16
C 319 (A,110,135)		CKSRYB104K16

### **D** GUARD-C ASSY

GUARD-C Assy has no service part.

### **E** GUARD-F ASSY

#### **MISCELLANEOUS**

921 (A,245,238) PCB BINDER VEF1040

### **G** DSP ASSY

#### **MISCELLANEOUS**

IC 101 (A,58,43) DSP IC ADSP-21366KBCZ-1AA  
 IC 103 (A,17,46) LOGIC IC (LATCHES) TC74VHC573FTS1

Mark No.	Description	Part No.	Mark No.	Description	Part No.
IC 104 (B,17,21)	LOGIC IC (LATCHES)	TC74VHC573FTS1	R 109 (A,54,34)		RS1/16SS101J
IC 105 (B,24,16)	2 TO 4 LINE DECODER	TC7W139FU	R 111 (A,53,51)		RS1/16SS472J
IC 106 (A,11,29)	FLASH ROM	AYW7167	R 112 (A,56,51)		RS1/16SS101J
IC 107 (A,34,52)	SRAM(4M)	CY7C1049D3310VX1	R 113 (A,57,51)		RS1/16SS101J
IC 109 (B,9,20)	1 CHIP OR GATE	TC7SH32FUS1	R 114 (A,58,51)		RS1/16SS101J
IC 201 (A,113,38)	DSP IC	DSPC56371AF180	R 115 (A,59,51)		RS1/16SS220J
IC 291 (B,146,42)	IC	TC74VHC08FTS1	R 116 (A,58,34)	RESISTOR ARRAY	RAB4CQ220J
IC 301 (A,191,37)	DA I/F TRANSCEIVER	AK4114VQ	R 117 (A,60,51)		RS1/16SS220J
IC 401 (A,154,29)	AUDIO 8CH DAC	AK4359VF	R 118 (A,61,51)		RS1/16SS471J
IC 481 (A,176,28)	AD CONVERTER IC	AK5358AET	R 119 (A,61,34)	RESISTOR ARRAY	RAB4CQ220J
IC 551 (A,106,23)	LOGIC IC	TC7WHU04FU	R 120 (A,63,34)		RS1/16SS470J
IC 552 (A,93,16)	LOGIC IC	TC7SHU04FUS1	R 121 (A,63,51)	RESISTOR ARRAY	RAB4CQ101J
IC 651 (A,163,44)	IC	TC74VHC157FTS1	R 122 (A,65,34)		RS1/16SS470J
IC 701 (A,164,60)	LIPSYNC IC	ML87V5002	R 123 (A,66,38)		RS1/16SS220J
IC 751 (B,164,60)	LIPSYNC IC	ML87V5002	R 124 (A,66,36)	RESISTOR ARRAY	RAB4CQ220J
△ IC 901 (A,48,16)	DC/DC CONVERTER IC	BD9107FVM	R 125 (A,66,40)	RESISTOR ARRAY	RAB4CQ220J
△ IC 903 (A,208,28)	REGURATOR IC	PQ1LAX95MSPQ	R 126 (A,66,47)	RESISTOR ARRAY	RAB4CQ220J
△ IC 904 (B,192,27)	REGURATOR IC	PQ1LAX95MSPQ	R 127 (A,46,39)		RS1/16SS472J
D 401 (B,167,23)	DIODE	MA152WA	R 128 (A,49,38)		RS1/16SS472J
D 402 (A,164,20)	DIODE	MA152WK	R 129 (A,45,45)		RS1/16SS472J
L 101 (A,70,40)	CHIP SOLID INDUCTOR	QTL1013	R 132 (A,50,44)		RS1/16SS101J
L 103 (A,45,42)	CHIP SOLID INDUCTOR	QTL1013	R 134 (A,50,46)		RS1/16SS101J
L 104 (A,20,52)	CHIP SOLID INDUCTOR	QTL1013	R 136 (A,50,48)		RS1/16SS101J
L 105 (B,13,16)	CHIP SOLID INDUCTOR	QTL1013	R 138 (A,50,39)		RS1/16SS101J
L 106 (B,27,20)	CHIP SOLID INDUCTOR	QTL1013	R 139 (A,66,44)		RS1/16SS101J
L 107 (B,13,36)	CHIP SOLID INDUCTOR	QTL1013	R 140 (A,66,43)		RS1/16SS101J
L 108 (B,34,55)	CHIP SOLID INDUCTOR	QTL1013	R 141 (B,14,47)	RESISTOR ARRAY	RAB4CQ470J
L 201 (B,106,31)	CHIP SOLID INDUCTOR	QTL1013	R 142 (B,14,44)	RESISTOR ARRAY	RAB4CQ470J
L 202 (A,127,41)	CHIP SOLID INDUCTOR	ATL7002	R 143 (B,16,26)	RESISTOR ARRAY	RAB4CQ470J
L 203 (A,117,26)	CHIP SOLID INDUCTOR	ATL7002	R 144 (B,18,26)	RESISTOR ARRAY	RAB4CQ470J
L 291 (B,151,42)	CHIP SOLID INDUCTOR	QTL1013	R 145 (B,21,45)	RESISTOR ARRAY	RAB4CQ470J
L 301 (B,185,41)	CHIP SOLID INDUCTOR	QTL1013	R 146 (B,21,47)	RESISTOR ARRAY	RAB4CQ470J
L 302 (A,180,35)	CHIP SOLID INDUCTOR	QTL1013	R 147 (B,16,15)		RS1/16SS470J
L 401 (B,160,25)	CHIP SOLID INDUCTOR	QTL1013	R 148 (B,19,15)	RESISTOR ARRAY	RAB4CQ470J
L 481 (B,169,32)	CHIP SOLID INDUCTOR	QTL1013	R 149 (B,24,21)		RS1/16SS470J
L 482 (B,182,26)	CHIP SOLID INDUCTOR	QTL1013	R 150 (B,23,21)		RS1/16SS470J
L 551 (A,109,23)	CHIP SOLID INDUCTOR	QTL1013	R 153 (B,11,19)		RS1/16SS470J
L 651 (A,159,40)	CHIP SOLID INDUCTOR	QTL1013	R 154 (B,10,23)		RS1/16SS472J
L 701 (A,152,66)	CHIP SOLID INDUCTOR	QTL1013	R 159 (A,26,47)		RS1/16SS220J
L 751 (B,186,55)	CHIP SOLID INDUCTOR	QTL1013	R 160 (A,41,56)		RS1/16SS0R0J
L 901 (B,195,22)	CHIP SOLID INDUCTOR	ATL7002	R 163 (A,16,41)		RS1/16SS220J
L 902 (B,188,23)	CHIP SOLID INDUCTOR	ATL7002	R 164 (B,7,23)		RS1/16SS0R0J
L 903 (B,182,24)	CHIP SOLID INDUCTOR	ATL7002	R 201 (A,116,48)	RESISTOR ARRAY	RAB4CQ101J
L 905 (A,63,22)	CHIP BEADS	ATL7010	R 202 (B,116,42)	RESISTOR ARRAY	RAB4CQ103J
L 906 (A,47,23)	POWER INDUCTOR	ATH7047	R 207 (B,114,42)		RS1/16SS473J
JA 351 (A,225,22)	JACK	AKB7131	R 209 (B,109,33)		RS1/16SS472J
X 551 (A,98,22)	CRYSTAL RESONATOR	XSS3003	R 212 (B,108,35)		RS1/16SS473J
CN301 (A,185,47)	10P CONNECTOR	VKN1414	R 214 (A,102,36)		RS1/16SS101J
CN401 (A,165,15)	23P SOCKET	XKP3083	R 215 (B,102,34)		RS1/16SS101J
CN801 (A,141,61)	B TO B CONNECTOR 30P	VKN1627	R 216 (A,102,34)		RS1/16SS101J
CN901 (A,173,11)	PLUG	CKS1764	R 217 (B,102,33)		RS1/16SS101J
CN951 (A,128,15)	23P SOCKET	XKP3083	R 218 (B,102,31)		RS1/16SS101J
			R 219 (B,99,31)		RS1/16SS472J
			R 220 (A,110,27)		RS1/16SS101J
			R 222 (B,108,33)		RS1/16SS101J
			R 226 (B,116,33)		RS1/16SS473J
			R 228 (B,109,30)		RS1/16SS472J
			R 233 (B,124,32)		RS1/16SS470J
			R 237 (B,121,40)		RS1/16SS470J
			R 238 (A,124,43)	RESISTOR ARRAY	RAB4CQ470J

### RESISTORS

R 103 (A,50,45)	RS1/16SS101J
R 104 (A,50,47)	RS1/16SS101J
R 106 (A,51,34)	RESISTOR ARRAY RAB4CQ472J
R 107 (A,54,51)	RS1/16SS472J
R 108 (A,56,34)	RS1/16SS472J

5	6	7	8
<u>Mark No.</u>	<u>Description</u>	<u>Part No.</u>	<u>Mark No.</u> <u>Description</u> <u>Part No.</u>
R 244 (A,121,49)		RS1/16SS470J	R 703 (A,173,59) RS1/16SS470J
R 246 (A,123,46)		RS1/16SS470J	R 704 (A,178,60) RESISTOR ARRAY RAB4CQ470J
R 248 (A,119,27)		RS1/16SS470J	R 711 (A,152,63) RS1/16SS101J
R 250 (A,119,28)		RS1/16SS470J	R 712 (A,152,62) RS1/16SS101J
R 261 (B,121,31)		RS1/16SS222J	R 713 (A,149,61) RS1/16SS101J
R 291 (A,148,45)		RS1/16SS220J	R 714 (A,149,59) RS1/16SS101J
R 292 (A,146,45)		RS1/16SS220J	R 715 (A,154,58) RESISTOR ARRAY RAB4CQ221J
R 293 (B,139,41)		RS1/16SS220J	R 719 (A,154,56) RS1/16SS221J
R 294 (B,139,43)		RS1/16SS220J	R 720 (A,154,55) RS1/16SS221J
R 296 (A,151,45)		RS1/16SS220J	R 751 (B,154,56) RS1/16SS470J
R 297 (A,149,45)		RS1/16SS220J	R 752 (B,186,59) RS1/16SS103J
R 302 (B,193,44) RESISTOR ARRAY		RAB4CQ104J	R 753 (B,184,59) RS1/16SS472J
R 307 (B,195,38)		RS1/16SS0R0J	R 754 (B,182,59) RS1/16SS472J
R 311 (A,184,38)		RS1/16SS101J	R 755 (B,173,61) RS1/16SS101J
R 312 (A,185,34)		RS1/16SS470J	R 756 (B,186,60) RS1/16SS101J
R 313 (A,185,32)		RS1/16SS101J	R 757 (B,184,60) RS1/16SS101J
R 314 (B,186,34)		RS1/16SS101J	R 758 (B,181,60) RS1/16SS101J
R 315 (B,186,33)		RS1/16SS101J	R 759 (B,173,58) RESISTOR ARRAY RAB4CQ101J
R 317 (A,189,28)		RS1/16SS470J	R 761 (B,187,57) RS1/16SS0R0J
R 318 (A,191,30)		RS1/16SS470J	R 763 (B,175,55) RS1/16SS101J
R 320 (A,199,33)		RS1/16S0R0J	R 764 (B,173,55) RS1/16SS101J
R 321 (A,196,30) RESISTOR ARRAY		RAB4CQ101J	R 801 (A,154,50) RS1/16SS104J
R 324 (B,193,32)		RS1/16SS103J	R 802 (B,154,57) RS1/16SS0R0J
R 325 (A,200,37) CHIP RESISTOR		RS1/16SS1802F	R 803 (A,175,59) RS1/16SS0R0J
R 351 (B,200,32)		RS1/16SS750J	R 805 (A,102,63) RESISTOR ARRAY RAB4CQ104J
R 352 (B,200,38)		RS1/16SS750J	R 806 (A,102,60) RESISTOR ARRAY RAB4CQ104J
R 361 (B,195,36)		RS1/16SS100J	R 810 (A,106,65) RESISTOR ARRAY RAB4CQ104J
R 362 (B,198,38)		RS1/16SS100J	R 901 (A,204,21) RS1/16SS104J
R 401 (A,157,34)		RS1/16SS470J	R 903 (A,47,13) CHIP RESISTOR RS1/16SS3003F
R 402 (A,162,36)		RS1/16SS470J	R 904 (A,46,16) RS1/16SS9101F
R 404 (A,153,35) RESISTOR ARRAY		RAB4CQ101J	R 905 (A,46,14) CHIP RESISTOR RS1/16SS1802F
R 407 (B,152,32)		RS1/16S4R7J	R 907 (A,205,26) CHIP RESISTOR RS1/16SS1202F
R 408 (A,146,19)		RS1/16SS101J	R 908 (A,205,29) RS1/16SS2002F
R 409 (A,148,19)		RS1/16SS101J	R 909 (B,196,29) CHIP RESISTOR RS1/16SS1202F
R 410 (A,150,19)		RS1/16SS101J	R 910 (B,193,30) CHIP RESISTOR RS1/16SS1000F
R 411 (A,152,19)		RS1/16SS101J	R 929 (A,186,19) RS1/16SS104J
R 412 (A,154,19)		RS1/16SS101J	R 930 (A,187,19) RS1/16SS104J
R 413 (A,156,19)		RS1/16SS101J	R 931 (A,202,21) RS1/16SS104J
R 414 (A,158,19)		RS1/16SS101J	R 951 (A,109,18) RESISTOR ARRAY RAB4CQ104J
R 415 (A,160,19)		RS1/16SS101J	R 955 (A,86,22) RS1/16SS472J
R 481 (A,180,29)		RS1/16SS101J	R 962 (A,83,15) RS1/16SS104J
R 482 (A,176,34)		RS1/16SS470J	R 977 (A,91,21) RS1/16SS0R0J
R 483 (A,175,34)		RS1/16SS470J	R 978 (A,87,21) RS1/16SS0R0J
R 503 (A,201,49)		RS1/16SS0R0J	R 979 (B,93,33) RESISTOR ARRAY RAB4CQ0R0J
R 551 (A,100,25)		RS1/16SS105J	R 980 (B,88,37) RS1/16SS0R0J
R 552 (A,97,25)		RS1/16SS471J	R 981 (B,82,54) RESISTOR ARRAY RAB4CQ0R0J
R 554 (A,104,22)		RS1/16SS220J	R 982 (B,76,57) RESISTOR ARRAY RAB4CQ0R0J
R 555 (A,92,18)		RS1/16SS220J	
R 557 (B,108,23)		RS1/16SS220J	
R 613 (A,169,45)		RS1/16SS0R0J	
R 614 (A,168,42)		RS1/16SS0R0J	
R 615 (A,156,39)		RS1/16SS0R0J	
R 616 (A,158,41)		RS1/16SS0R0J	
R 651 (A,166,39) RESISTOR ARRAY		RAB4CQ101J	
R 654 (A,167,49) RESISTOR ARRAY		RAB4CQ470J	
R 657 (A,157,46) RESISTOR ARRAY		RAB4CQ470J	
R 660 (A,157,43) RESISTOR ARRAY		RAB4CQ101J	
R 668 (A,164,40)		RS1/16SS104J	
R 701 (A,168,54)		RS1/16SS470J	
R 702 (A,173,58)		RS1/16SS470J	
			<b>CAPACITORS</b>
			C 101 (A,73,33) CEVW101M16
			C 102 (A,45,30) CHIP OS CAPACITOR ACH1429
			C 103 (B,53,40) CKSSYB104K10
			C 104 (B,53,43) CKSSYB104K10
			C 105 (B,57,48) CKSSYB104K10
			C 106 (B,63,45) CKSSYB104K10
			C 107 (B,62,41) CKSSYB104K10
			C 108 (B,59,38) CKSSYB104K10
			C 109 (A,49,42) CKSSYB104K10
			C 110 (A,50,42) CKSSYB471K50

	<u>Mark No.</u>	<u>Description</u>	<u>Part No.</u>	<u>Mark No.</u>	<u>Description</u>	<u>Part No.</u>
A	C 111	(B,53,45)	CKSSYB471K50	C 318	(A,199,35)	CCSRCH471J50
	C 112	(B,52,45)	CKSSYB104K10	C 319	(A,199,38)	CKSRYB474K10
	C 113	(B,53,48)	CKSSYB471K50	C 353	(B,197,35)	CKSSYB103K16
	C 114	(B,54,47)	CKSSYB104K10	C 354	(B,199,38)	CKSSYB103K16
	C 115	(B,59,47)	CKSSYB471K50	C 401	(A,148,30)	CKSSYB471K50
	C 116	(B,59,48)	CKSSYB104K10	C 402	(A,147,30)	CKSRYB104K16
	C 117	(B,61,47)	CKSSYB471K50	C 403	(A,147,38)	CEVW101M16
	C 118	(B,61,48)	CKSSYB104K10	C 404	(A,155,34)	CKSSYB104K10
	C 119	(B,62,43)	CKSSYB471K50	C 407	(A,146,18)	CKSSYB471K50
	C 120	(B,63,43)	CKSSYB104K10	C 408	(A,148,18)	CKSSYB471K50
B	C 121	(B,62,39)	CKSSYB471K50	C 409	(A,150,18)	CKSSYB471K50
	C 122	(B,64,39)	CKSSYB104K10	C 410	(A,152,18)	CKSSYB471K50
	C 123	(B,61,37)	CKSSYB471K50	C 411	(A,154,18)	CKSSYB471K50
	C 124	(B,61,38)	CKSSYB104K10	C 412	(A,156,18)	CKSSYB471K50
	C 125	(B,56,38)	CKSSYB471K50	C 413	(A,158,18)	CKSSYB471K50
	C 126	(B,57,37)	CKSSYB104K10	C 414	(A,160,18)	CKSSYB471K50
	C 127	(B,55,38)	CKSSYB471K50	C 415	(A,161,24)	CCSRCH471J50
	C 128	(B,54,38)	CKSSYB104K10	C 416	(A,163,24)	CKSRYB104K16
	C 129	(A,47,47)	CKSSYB103K16	C 417	(A,162,29)	CEVW101M16
	C 139	(A,47,42)	CKSRYB105K16	C 418	(A,144,23)	CEVW470M6R3
C	C 174	(A,8,48)	CEVW101M16	C 420	(A,147,28)	CKSSYB104K10
	C 176	(A,18,52)	CKSSYB104K10	C 481	(A,180,28)	CKSSYB104K10
	C 178	(B,11,21)	CKSSYB104K10	C 482	(A,173,23)	CKSSYB104K10
	C 180	(B,28,16)	CKSSYB104K10	C 483	(A,169,24)	CKSQYB225K10
	C 182	(A,11,42)	CKSSYB104K10	C 485	(A,176,23)	CCSRCH471J50
	C 184	(A,42,52)	CKSSYB104K10	C 486	(A,176,21)	CKSRYB104K16
	C 186	(A,25,52)	CKSSYB104K10	C 487	(A,169,30)	CEVW101M16
	C 188	(B,5,20)	CKSSYB104K10	C 489	(A,178,22)	CKSSYB104K10
	C 202	(A,119,49)	CKSSYB104K10	C 490	(A,183,24)	CEVW100M16
	C 203	(A,113,47)	CKSSYB471K50	C 552	(A,106,18)	CKSSYB104K10
	C 204	(A,113,48)	CKSSYB104K10	C 553	(A,106,20)	CCSRCH471J50
	C 206	(A,108,48)	CKSSYB104K10	C 554	(A,102,25)	CCSSCH8R0D50
	C 208	(A,102,41)	CKSSYB104K10	C 555	(A,95,25)	CCSSCH8R0D50
	C 209	(A,103,39)	CKSSYB471K50	C 556	(A,92,14)	CCSRCH471J50
	C 210	(A,102,39)	CKSSYB104K10	C 557	(A,92,13)	CKSSYB104K10
D	C 211	(A,103,31)	CKSSYB471K50	C 652	(A,162,39)	CKSSYB104K10
	C 212	(A,103,30)	CKSSYB104K10	C 701	(A,145,65)	CEVW100M16
	C 216	(A,106,28)	CKSSYB471K50	C 703	(A,173,61)	CKSSYB104K10
	C 217	(A,106,27)	CKSSYB104K10	C 705	(A,160,65)	CKSSYB104K10
	C 218	(A,109,28)	CKSSYB471K50	C 707	(A,159,54)	CKSSYB104K10
	C 219	(A,109,27)	CKSSYB104K10	C 708	(A,155,61)	CKSSYB104K10
	C 220	(B,111,33)	CKSSYB103K16	C 751	(A,184,58)	CEVW100M16
	C 221	(A,114,28)	CKSSYB471K50	C 753	(B,154,61)	CKSSYB104K10
	C 222	(A,114,26)	CKSSYB104K10	C 755	(B,165,64)	CKSSYB104K10
	C 224	(A,124,34)	CKSSYB104K10	C 757	(B,168,54)	CKSSYB104K10
E	C 225	(A,123,37)	CKSSYB471K50	C 758	(B,172,61)	CKSSYB104K10
	C 226	(A,124,37)	CKSSYB104K10	C 801	(A,137,65)	CKSRYB104K16
	C 228	(A,124,40)	CKSSYB104K10	C 902	(A,51,23)	DCH1201
	C 229	(A,132,44) CHIP ELECT.CAPACITOR	CEVW101M4	C 903	(A,51,17)	DCH1201
	C 230	(A,114,21)	CEVW101M16	C 904	(A,49,13)	CKSSYB102K50
	C 291	(B,145,38)	CCSRCH471J50	C 905	(A,209,33)	CKSRYB105K16
	C 292	(B,145,37)	CKSSYB104K10	C 906	(A,206,33)	CKSRYB105K16
	C 304	(A,185,41)	CKSRYB104K16	C 907	(B,187,26)	CKSRYB105K16
	C 305	(A,180,39)	CEVW470M6R3	C 908	(B,188,28)	CKSRYB105K16
	C 306	(A,184,36)	CCSRCH471J50	C 918	(B,181,24)	CKSSYB103K16
F	C 307	(A,185,36)	CKSSYB104K10	C 921	(B,120,36)	CKSSYB471K50
	C 312	(B,192,32)	CKSSYB104K10	C 922	(B,122,36)	CKSSYB103K16
	C 315	(B,194,32)	CKSSYB102K50	C 923	(B,179,23)	CKSSYB104K10
	C 316	(A,201,28)	CEVW470M6R3	C 924	(B,179,22)	CKSSYB471K50
	C 317	(A,200,35)	CKSSYB104K10			

5	6	7	8
Mark No.	Description	Part No.	Mark No. Description Part No.
<b>H COMPOSITE ASSY</b>			
<b>MISCELLANEOUS</b>			
IC 1001(A,74,199)	LOGIC IC	TC74HC4051AFT	R 1033(B,54,189) RS1/16S473J
IC 1003(A,92,208)	IC	TC74HC4053AFT	R 1034(A,42,176) RS1/16S102J
IC 1004(A,112,209)	VIDEO AMP IC	LA7109	R 1035(B,28,186) RS1/16S512J
IC 1005(B,56,197)	PORT EXPANDER	BU4094BCF	R 1036(B,30,186) RS1/16S392J
IC 1006(A,36,184)	CHARACTER GENERATOR	PDC162A	
IC 1101(A,159,189)	OP-AMP IC	UPC4570G2	R 1037(B,38,188) RS1/16S102J
Q 1002(A,171,176)	TRANSISTOR	2SC4081	R 1039(A,24,192) RS1/16S331J
Q 1003(B,27,193)	TRANSISTOR	2SC4081	R 1040(A,25,196) RS1/16S331J
Q 1004(B,179,188)	TRANSISTOR	2SC4081	R 1041(A,26,196) RS1/16S331J
Q 1102(A,173,207)	DIGITAL TR(SC-70)	RT1N431M	R 1043(B,175,192) RS1/16S561J
D 1001(B,88,192)	DIODE	DAN202U	R 1046(B,179,190) RS1/16S102J
D 1002(B,84,192)	DIODE	DAN202U	R 1049(A,168,175) RS1/16S103J
D 1003(B,132,179)	DIODE	1SS355	R 1051(A,168,176) RS1/16S0R0J
D 1004(B,123,176)	DIODE	1SS355	R 1054(B,90,209) RS1/16S473J
D 1005(B,57,180)	DIODE	DAP202U	R 1101(A,162,205) RS1/16S104J
D 1101(A,163,208)	DIODE	UDZS6R2(B)	R 1102(A,158,206) RS1/16S104J
D 1102(A,157,208)	DIODE	UDZS6R2(B)	R 1103(A,164,205) RS1/16S331J
D 1103(A,163,210)	DIODE	UDZS6R2(B)	R 1104(A,155,205) RS1/16S331J
D 1104(A,158,209)	DIODE	UDZS6R2(B)	R 1105(B,163,199) RS1/16S104J
D 1105(A,172,201)	DIODE	1SS355	R 1106(B,156,199) RS1/16S104J
D 1108(B,178,206)	DIODE	UDZS5R1(B)	R 1107(B,163,193) RS1/16S472J
D 1109(B,176,206)	DIODE	UDZS5R1(B)	R 1108(B,157,193) RS1/16S472J
D 1110(B,169,207)	DIODE	UDZS5R1(B)	R 1109(B,168,195) RS1/16S472J
L 1002(B,181,194)	CHIP COIL	LCTAW120J2520	R 1110(B,150,195) RS1/16S472J
L 1003(A,33,200)	AXIAL INDUCTOR	LAU330J	R 1111(B,163,190) RS1/16S103J
JA 1006(A,57,233)	PIN JACK(1P)	AKB7175	R 1112(B,155,189) RS1/16S103J
X 1001(A,44,196)	CRYSTAL RESONATOR	ASS7080	R 1113(A,165,188) RS1/16S103J
CN1001(A,184,173)	11P SOCKET	XKP3076	R 1114(A,154,189) RS1/16S103J
CN1002(A,77,178)	21P SOCKET	XKP3081	R 1115(B,162,183) RS1/16S101J
CN1003(A,184,198)	13P SOCKET	XKP3077	R 1116(B,156,183) RS1/16S101J
CN1004(A,161,233)	20P SOCKET	AKP7202	R 1117(B,169,185) RS1/16S104J
1001(A,134,233)	PIN JACK(2P)	AKB7176	R 1118(B,167,182) RS1/16S104J
1002(A,106,233)	PIN JACK(2P)	AKB7176	R 1122(A,170,205) RS1/16S514J
1003(A,78,233)	PIN JACK(2P)	AKB7176	R 1124(A,170,208) RS1/16S393J
			R 1127(B,174,212) RS1/16S0R0J
			R 1131(A,154,212) RS1/16S750J
			R 1132(A,150,208) RS1/16S0R0J
			R 1134(A,152,213) RS1/16S0R0J
			R 1167(A,111,203) RS1/16S0R0J
<b>RESISTORS</b>			<b>CAPACITORS</b>
R 1001(B,142,224)	RS1/16S750J		C 1001(A,75,202) CKSRYB104K16
R 1002(B,125,221)	RS1/16S750J		C 1002(A,73,204) CKSRYB104K16
R 1003(B,97,220)	RS1/16S750J		C 1005(A,91,212) CKSRYB104K16
R 1004(B,69,220)	RS1/16S750J		C 1006(A,94,212) CKSRYB104K16
R 1007(B,81,220)	RS1/16S750J		C 1008(B,65,202) CKSRYB104K16
R 1009(B,108,220)	RS1/16S750J		
R 1011(B,54,219)	RS1/16S750J		C 1009(B,68,189) CCSRCH561J50
R 1014(A,169,170)	RS1/16S102J		C 1011(A,169,173) CKSRYB103K50
R 1017(B,105,201)	RS1/16S103J		C 1012(A,169,172) CKSRYB103K50
R 1018(B,114,201)	RS1/16S103J		C 1014(A,88,202) CEAT101M10
R 1020(B,131,201)	RS1/16S103J		C 1016(A,116,200) CEAT101M10
R 1021(A,108,203)	RS1/16S103J		
R 1022(A,117,203)	RS1/16S103J		C 1018(A,134,200) CEAT101M10
R 1023(B,133,204)	RS1/16S473J		C 1019(B,116,211) CKSRYB104K16
R 1024(B,135,205)	RS1/16S473J		C 1020(A,120,208) CKSRYB104K16
R 1025(B,66,204)	RS1/16S473J		C 1021(A,123,213) CEAT101M10
R 1026(B,63,204)	RS1/16S473J		C 1022(A,129,214) CEAT101M10
R 1027(B,64,189)	RS1/16S561J		
R 1030(B,85,196)	RS1/16S473J		C 1024(B,84,225) CCSRCH181J50
R 1031(B,71,192)	RS1/16S473J		C 1025(B,113,224) CCSRCH181J50
R 1032(B,69,192)	RS1/16S473J		C 1026(B,56,224) CCSRCH181J50
			C 1027(A,45,180) CEAT101M10
			C 1028(A,45,187) CEAT101M10

Mark No.	Description	Part No.	Mark No.	Description	Part No.
			L	1301(B,161,128) CHIP SOLID INDUCTOR	QTL1013
			CN	1201(A,175,128) 13P SOCKET	XKP3077
A	C 1029(A,45,177)	CKSRYB473K25			
	C 1030(A,27,185)	CKSRYB473K25			
	C 1031(A,39,176)	CCSRCH101J50	CN	1202(A,175,101) 15P SOCKET	XKP3078
	C 1032(A,35,176)	CKSRYB122K50	CN	1203(A,68,108) 15P SOCKET	XKP3078
	C 1033(A,31,176)	CKSRYB122K50	CN	1204SOCKET	XKB3052
			CN	1205(A,97,163) SOCKET	XKB3051
	C 1035(B,34,186)	CKSRYB103K50	CN	1206(A,125,163) SOCKET	XKB3051
	C 1036(B,47,191)	CCSRCH5R0C50			
	C 1037(B,45,191)	CCSRCH5R0C50			
	C 1038(B,33,193)	CCSRCH240J50	CN	1302(A,175,152) 7P FFC CONNECTOR	RKN1048
	C 1039(B,32,197)	CCSRCH240J50			
	C 1040(A,29,194)	CCSRCH101J50			
	C 1041(A,28,193)	CCSRCH101J50			
	C 1042(A,26,192)	CCSRCH101J50			
B	C 1045(B,184,192)	CCSRCH330J50			
	C 1046(B,178,193)	CCSRCH120J50			
	C 1047(B,180,192)	CCSRCJ3R0C50			
	C 1093(B,111,224)	CKSRYB103K50	R	1201(B,131,152)	RS1/16S750J
	C 1095(B,82,225)	CKSRYB103K50	R	1202(B,133,152)	RS1/16S750J
	C 1096(B,79,225)	CKSRYB103K50	R	1203(B,117,152)	RS1/16S750J
	C 1097(B,54,224)	CKSRYB103K50	R	1204(B,119,152)	RS1/16S750J
			R	1205(B,89,152)	RS1/16S750J
	C 1098(B,43,224)	CKSRYB103K50	R	1206(B,91,152)	RS1/16S750J
	C 1101(A,162,206)	CCSRCH101J50	R	1207(B,61,151)	RS1/16S750J
	C 1102(A,158,205)	CCSRCH101J50	R	1208(B,63,151)	RS1/16S750J
	C 1103(A,160,200)	CCSRCH101J50	R	1209(B,47,148)	RS1/16S750J
C	C 1104(A,158,200)	CCSRCH101J50	R	1210(B,49,148)	RS1/16S750J
	C 1105(A,163,201)	CEAT100M50	R	1211(B,103,149)	RS1/16S750J
	C 1106(A,155,201)	CEAT100M50	R	1212(B,105,149)	RS1/16S750J
	C 1107(A,168,197)	CEAT100M50	R	1213(B,75,149)	RS1/16S750J
	C 1108(A,150,197)	CEAT100M50	R	1214(B,77,149)	RS1/16S750J
	C 1113(A,157,193)	CKSRYB103K50	R	1218(B,147,132)	RS1/16S473J
	C 1114(A,162,193)	CKSRYB103K50	R	1223(B,138,115)	RS1/16S102J
	C 1115(A,162,180)	CEAT100M50	R	1224(B,138,105)	RS1/16S102J
	C 1116(A,156,180)	CEAT100M50	R	1225(A,59,132)	RS1/16S103J
	C 1117(A,174,198)	CKSRYB103K50	R	1226(A,63,132)	RS1/16S103J
	C 1118(B,167,224)	CKSRYB103K50	R	1227(A,66,130)	RS1/16S103J
D	C 1121(A,183,192)	CKSRYB103K50	R	1228(A,87,131)	RS1/16S103J
	C 1122(A,185,192)	CKSRYB103K50	R	1231(B,80,137)	RS1/16S473J
			R	1232(A,71,130)	RS1/16S473J
			R	1235(A,155,111)	RS1/16S561J
			R	1236(B,167,108)	RS1/16S561J
			R	1237(B,131,115)	RS1/16S103J
			R	1238(B,132,106)	RS1/16S103J
			R	1243(A,145,119)	RS1/16S102J
			R	1244(B,157,104)	RS1/16S102J
			R	1247(A,146,123)	RS1/16S103J
			R	1248(A,144,124)	RS1/16S470J
			R	1249(A,146,126)	RS1/16S274J
			R	1251(B,130,115)	RS1/16S0R0J
			R	1252(B,130,106)	RS1/16S0R0J
			R	1257(A,151,121)	RS1/16S0R0J
			R	1310(A,175,147)	RS1/16S103J
			R	1627(A,72,133)	RS1/16S0R0J
			R	1628(A,66,133)	RS1/16S0R0J

**RESISTORS****S-VIDEO ASSY  
MISCELLANEOUS**

	IC 1201(A,115,134) LOGIC IC	TC74HC4051AFT			
	IC 1202(A,103,134) LOGIC IC	TC74HC4051AFT			
	IC 1203(A,111,119) IC	TC74HC4053AFT			
	IC 1205(A,66,138) VIDEO AMP IC	LA7109			
E	IC 1206(A,149,126) IC	NJM12904V			
	Q 1201(B,145,132) TRANSISTOR	RT1N241M			
	Q 1203(B,135,115) TRANSISTOR	2SC4081			
	Q 1204(B,135,106) TRANSISTOR	2SC4081			
	Q 1205(A,148,116) TRANSISTOR	2SC4081			
	Q 1206(B,155,106) TRANSISTOR	2SC4081			
	D 1203(B,79,133) DIODE	DAN202K			
	D 1204(A,83,129) DIODE	DAN202K			
	D 1205(A,143,125) DIODE	1SS355			
	D 1251(B,90,112) DIODE	1SS355			
	D 1252(B,79,113) DIODE	1SS355			
F	D 1301(B,170,143) DIODE	1SS355			
	L 1201(A,155,109) CHIP COIL	LCTAW120J2520			
	L 1202(B,162,108) CHIP COIL	LCTAW120J2520			
			C	1201(B,133,148)	CKSRYB104K16
			C	1202(B,119,148)	CKSRYB104K16
			C	1203(B,91,148)	CKSRYB104K16
			C	1204(B,63,148)	CKSRYB104K16
			C	1205(B,49,151)	CCSRCH181J50
			C	1206(B,47,151)	CCSRCH181J50
			C	1207(B,105,152)	CCSRCH181J50
			C	1208(B,103,152)	CCSRCH181J50
			C	1209(B,77,152)	CCSRCH181J50

**CAPACITORS**

Mark No.	Description	Part No.	Mark No.	Description	Part No.
C 1210(B,75,152)		CCSRCH181J50	Q 1417(B,167,42)	TRANSISTOR	2SC4081
C 1211(A,111,134)		CKSRYP104K16	Q 1501(A,62,65)	TRANSISTOR	IMX25
C 1212(A,119,132)		CKSRYP104K16	Q 1502(A,68,65)	TRANSISTOR	IMX25
C 1213(A,99,134)		CKSRYP104K16	Q 1521(A,49,65)	TRANSISTOR	IMX25
C 1214(A,107,131)		CKSRYP104K16	Q 1522(A,55,65)	TRANSISTOR	IMX25
C 1215(A,115,115)		CKSRYP104K16	Q 1541(A,36,65)	TRANSISTOR	IMX25
C 1216(A,108,121)		CKSRYP104K16	Q 1542(A,42,65)	TRANSISTOR	IMX25
C 1221(A,124,115)		CEAT101M10	Q 1561(A,22,65)	TRANSISTOR	IMX25
C 1222(A,124,107)		CEAT101M10	Q 1562(A,29,65)	TRANSISTOR	IMX25
C 1225(B,132,110)		CKSRYP103K50	D 1401(B,85,43)	DIODE	1SS355
C 1226(B,140,110)		CKSRYP103K50	D 1402(B,83,43)	DIODE	1SS355
C 1227(A,42,120)		CEAT101M10	L 1401(B,166,58)	CHIP COIL	LCTAW120J2520
C 1228(B,57,129)		CKSRYP104K16	L 1402(B,169,53)	CHIP COIL	LCTAW120J2520
C 1229(A,50,120)		CEAT101M10	L 1403(B,175,49)	CHIP COIL	LCTAW120J2520
C 1230(A,87,130)		CKSRYP104K16	JA 1401(A,141,94)	6P RCA PINJACK	XKB3053
C 1233(B,59,142)		CKSRYP104K16	JA 1402(A,99,94)	6P RCA PINJACK	XKB3053
C 1234(B,59,134)		CKSRYP104K16	CN 1401(A,175,56)	13P SOCKET	XKP3077
C 1235(A,53,143)		CEAT101M10	CN 1402(A,175,30)	11P SOCKET	XKP3076
C 1236(A,53,136)		CEAT101M10	CN 1403(A,68,39)	13P SOCKET	XKP3077
C 1237(A,151,117)		CKSRYP103K50	CN 1405(A,19,59)	17P SOCKET	XKP3079
C 1238(A,143,119)		CKSRYP103K50	CN 1406(A,53,41)	CONNECTOR	CKS3384
C 1239(B,159,106)		CKSRYP103K50	CN 1501(A,58,94)	PIN JACK(4P)	AKB7172
C 1240(B,160,104)		CKSRYP103K50	CN 1502(A,30,94)	PIN JACK(4P)	AKB7172
C 1241(A,144,122)		CKSRYP104K16	1401(A,166,28)	PCB BINDER	VEF1040
C 1242(A,143,130)		CEAT100M50			
C 1243(A,155,113)		CCSRCH120J50			
C 1244(B,167,109)		CCSRCH120J50			
C 1245(A,152,112)		CCSRCH330J50			
C 1246(B,158,110)		CCSRCH330J50			
C 1247(A,152,128)		CKSRYP104K16			
C 1249(A,154,107)		CCSRCJ3R0C50			
C 1250(B,162,111)		CCSRCJ3R0C50			
C 1292(B,73,158)		CKSRYP103K50			
C 1293(B,93,158)		CKSRYP103K50			
C 1294(B,129,158)		CKSRYP103K50			
C 1301(A,158,138)		CEAT101M16			
C 1302(A,153,142)		CKSRYP103K50			

### RESISTORS

R 1401(B,149,85)	RS1/16S750J
R 1402(B,138,85)	RS1/16S750J
R 1403(B,124,85)	RS1/16S750J
R 1404(B,157,85)	RS1/16S750J
R 1405(B,145,85)	RS1/16S750J
R 1406(B,131,85)	RS1/16S750J
R 1407(B,115,85)	RS1/16S750J
R 1408(B,103,85)	RS1/16S750J
R 1409(B,89,85)	RS1/16S750J
R 1410(B,106,77)	RS1/16S750J
R 1411(B,94,78)	RS1/16S750J
R 1412(B,83,79)	RS1/16S750J
R 1416(B,91,61)	RS1/16S102J
R 1417(B,85,57)	RS1/16S153J
R 1418(B,75,56)	RS1/16S153J
R 1419(B,82,58)	RS1/16S333J
R 1420(B,78,58)	RS1/16S333J
R 1421(B,159,64)	RS1/16S102J
R 1422(B,159,69)	RS1/16S102J
R 1423(B,159,74)	RS1/16S102J
R 1424(B,169,59)	RS1/16S561J
R 1425(B,171,54)	RS1/16S561J
R 1426(B,173,53)	RS1/16S561J
R 1430(B,133,54)	RS1/16S473J
R 1431(B,131,54)	RS1/16S473J
R 1432(B,131,50)	RS1/16S473J
R 1433(B,134,46)	RS1/16S473J
R 1434(A,134,46)	RS1/16S0R0J
R 1436(A,123,52)	RS1/16S561J
R 1439(B,126,49)	RS1/16S473J
R 1440(B,124,49)	RS1/16S473J
R 1441(B,128,48)	RS1/16S473J
R 1442(B,128,45)	RS1/16S473J
R 1443(B,157,64)	RS1/16S154J

## J BRIDGE 2 ASSY

### MISCELLANEOUS

CN2901(A,21,29)	17P PLUG	XKP3068
CN2902(A,100,29)	17P PLUG	XKP3068

## K COMPONENT ASSY

### MISCELLANEOUS

IC 1401(A,113,70)	MULTIPLEXER(4CH*2)	TC74LVX4052FT
IC 1402(A,124,72)	MULTIPLEXER(4CH*2)	TC74LVX4052FT
IC 1403(A,139,69)	MULTIPLEXER(2CH*3)	TC74LVX4053FT
IC 1404(B,93,70)	VIDEO IC	NJM2581M
IC 1405(A,129,50)	PORT EXPANDER IC	BU4094BCFV
Q 1401(B,87,57)	TRANSISTOR	2SC4081
Q 1402(B,71,57)	TRANSISTOR	2SA1576A
Q 1403(B,163,64)	TRANSISTOR	2SA1576A
Q 1405(B,163,69)	TRANSISTOR	2SA1576A
Q 1407(B,163,74)	TRANSISTOR	2SA1576A
Q 1415(B,156,59)	TRANSISTOR	2SC4081
Q 1416(B,162,50)	TRANSISTOR	2SC4081

**Mark No. Description****Part No.****Mark No. Description****Part No.**

R 1444(B,160,64)

RS1/16S124J

R 1574(A,62,46)

RS1/16S471J

R 1446(B,157,69)

RS1/16S154J

R 1575(A,63,44)

RS1/16S473J

R 1447(B,161,69)

RS1/16S124J

R 1576(A,61,43)

RS1/16S471J

R 1449(B,157,74)

RS1/16S154J

R 1581(B,151,77)

RS1/16S0R0J

R 1450(B,161,74)

RS1/16S124J

R 1461(B,162,60)

RS1/16S104J

**CAPACITORS**

R 1462(B,163,55)

RS1/16S104J

C 1413(A,118,70)

CKSRYB103K50

R 1463(B,166,48)

RS1/16S104J

C 1414(A,107,72)

CKSRYB103K50

R 1464(B,157,55)

RS1/16S102J

C 1415(A,131,70)

CKSRYB103K50

R 1465(B,166,52)

RS1/16S102J

C 1416(A,117,73)

CKSRYB103K50

R 1466(B,173,47)

RS1/16S102J

C 1417(A,143,67)

CKSRYB103K50

R 1501(B,62,59)

RS1/16S271J

C 1418(A,135,72)

CKSRYB103K50

R 1502(B,68,59)

RS1/16S271J

C 1419(A,101,61)

CEAT101M10

R 1503(B,62,65)

RS1/16S121J

C 1420(A,95,61)

CEAT101M10

R 1504(B,68,65)

RS1/16S121J

C 1421(A,97,53)

CEAT101M10

R 1505(B,62,70)

RS1/16S101J

C 1425(A,83,67)

CEAT101M10

R 1506(B,68,70)

RS1/16S101J

C 1426(A,83,73)

CEAT101M10

R 1507(B,63,86)

RS1/16S474J

C 1427(B,86,67)

CKSRYB104K16

R 1508(B,67,87)

RS1/16S474J

C 1428(B,86,72)

CKSRYB104K16

R 1509(A,62,60)

RS1/16S103J

C 1431(B,82,60)

CKSRYB224K10

R 1510(A,68,60)

RS1/16S103J

C 1432(B,78,60)

CKSRYB224K10

R 1511(A,60,69)

RS1/16S103J

C 1433(B,153,64)

CKSRYB103K50

R 1512(A,67,69)

RS1/16S103J

C 1434(B,168,64)

CKSRYB103K50

R 1521(B,49,59)

RS1/16S271J

C 1435(B,153,70)

CKSRYB103K50

R 1522(B,55,59)

RS1/16S271J

C 1436(B,168,69)

CKSRYB103K50

R 1523(B,49,65)

RS1/16S121J

C 1437(B,154,76)

CKSRYB103K50

R 1524(B,55,65)

RS1/16S121J

C 1438(B,168,73)

CKSRYB103K50

R 1525(B,49,70)

RS1/16S101J

C 1439(A,151,63)

CEAT100M50

R 1526(B,55,70)

RS1/16S101J

C 1440(A,151,68)

CEAT100M50

R 1527(B,49,86)

RS1/16S474J

C 1441(A,150,74)

CEAT100M50

R 1528(B,53,87)

RS1/16S474J

C 1443(B,169,41)

CKSRYB104K16

R 1529(A,49,60)

RS1/16S103J

C 1444(B,175,46)

CKSRYB104K16

R 1530(A,55,60)

RS1/16S103J

C 1445(A,170,59)

CCSRCH120J50

R 1531(A,47,69)

RS1/16S103J

C 1446(A,170,55)

CCSRCH120J50

R 1532(A,54,69)

RS1/16S103J

C 1447(A,172,50)

CCSRCH120J50

R 1541(B,36,59)

RS1/16S271J

C 1448(A,169,59)

CCSRCH330J50

R 1542(B,42,59)

RS1/16S271J

C 1449(A,169,55)

CCSRCH330J50

R 1543(B,36,65)

RS1/16S121J

C 1450(A,170,50)

CCSRCH330J50

R 1544(B,42,65)

RS1/16S121J

C 1454(A,170,57)

CCSRCH330J50

R 1545(B,36,70)

RS1/16S101J

C 1455(A,170,52)

CCSRCH330J50

R 1546(B,42,70)

RS1/16S101J

C 1456(A,172,48)

CCSRCH330J50

R 1547(B,35,86)

RS1/16S474J

C 1469(A,130,54)

CKSRYB104K16

R 1548(B,39,87)

RS1/16S474J

C 1470(A,128,54)

CCSRCH561J50

R 1549(A,36,60)

RS1/16S103J

C 1471(A,163,58)

CEAT100M50

R 1550(A,42,60)

RS1/16S103J

C 1472(A,163,53)

CEAT100M50

R 1551(A,34,69)

RS1/16S103J

C 1473(A,166,46)

CEAT100M50

R 1552(A,41,69)

RS1/16S103J

C 1490(B,147,85)

CKSRYB103K50

R 1561(B,23,61)

RS1/16S271J

C 1491(B,133,85)

CKSRYB103K50

R 1562(B,29,61)

RS1/16S271J

C 1492(B,105,85)

CKSRYB103K50

R 1563(B,22,65)

RS1/16S121J

C 1493(B,91,85)

CKSRYB103K50

R 1564(B,29,65)

RS1/16S121J

C 1501(B,63,84)

CCSRCH101J50

R 1565(B,22,70)

RS1/16S101J

C 1502(B,67,85)

CCSRCH101J50

R 1566(B,29,70)

RS1/16S101J

C 1507(B,60,70)

CCSRCH271J50

R 1567(B,21,86)

RS1/16S474J

C 1508(B,66,70)

CCSRCH271J50

R 1568(B,25,87)

RS1/16S474J

C 1521(B,49,84)

CCSRCH101J50

R 1569(A,23,60)

RS1/16S103J

C 1522(B,53,85)

CCSRCH101J50

R 1570(A,29,60)

RS1/16S103J

C 1527(B,47,70)

CCSRCH271J50

R 1571(A,21,69)

RS1/16S103J

C 1528(B,53,70)

CCSRCH271J50

R 1572(A,27,69)

RS1/16S103J

C 1531(A,60,78) ELECT. CAPACITOR

CEAT470M25

R 1573(A,65,46)

RS1/16S473J

C 1532(A,67,78) ELECT. CAPACITOR

CEAT470M25

Mark No.	Description	Part No.	Mark No.	Description	Part No.
C 1533(A,47,78)	ELECT. CAPACITOR	CEAT470M25	R 2307(B,116,240)		RS1/16S104J
C 1541(B,35,84)		CCSRCH101J50	R 2308(B,118,240)		RS1/16S104J
C 1542(B,39,85)		CCSRCH101J50	R 2309(B,120,240)		RS1/16S104J
C 1547(A,54,78)	ELECT. CAPACITOR	CEAT470M25	R 2310(B,122,240)		RS1/16S104J
C 1548(A,34,78)	ELECT. CAPACITOR	CEAT470M25	R 2311(B,124,240)		RS1/16S104J
C 1549(A,41,78)	ELECT. CAPACITOR	CEAT470M25	R 2312(B,126,240)		RS1/16S104J
C 1550(A,21,78)	ELECT. CAPACITOR	CEAT470M25	R 2313(B,128,240)		RS1/16S104J
C 1551(A,27,78)	ELECT. CAPACITOR	CEAT470M25	R 2314(B,130,240)		RS1/16S104J
C 1561(B,21,84)		CCSRCH101J50	R 2315(B,132,240)		RS1/16S104J
C 1562(B,25,85)		CCSRCH101J50	R 2316(B,134,240)		RS1/16S104J
C 1567(A,60,46)		CKSRYB472K50	R 2317(B,136,240)		RS1/16S104J
C 1568(A,58,44)		CKSRYB472K50	R 2318(B,138,240)		RS1/16S104J
C 1569(B,34,70)		CCSRCH271J50	R 2319(B,140,240)		RS1/16S104J
C 1570(B,40,70)		CCSRCH271J50	R 2320(B,142,240)		RS1/16S104J
C 1571(B,20,70)		CCSRCH271J50	R 2321(B,144,240)		RS1/16S104J
C 1572(B,27,70)		CCSRCH271J50	R 2322(B,146,240)		RS1/16S104J
C 1591(B,58,86)		CKSRYB103K50	R 2323(B,148,240)		RS1/16S104J
C 1593(B,30,86)		CKSRYB103K50	R 2324(B,150,240)		RS1/16S104J
			R 2325(B,152,240)		RS1/16S104J
			R 2326(B,154,240)		RS1/16S104J
			R 2327(B,156,240)		RS1/16S104J
			R 2328(B,158,240)		RS1/16S104J
			R 2329(B,160,240)		RS1/16S104J
			R 2330(B,162,240)		RS1/16S104J
			R 2331(B,164,240)		RS1/16S104J
			R 2332(B,166,240)		RS1/16S104J
			R 2333(B,168,240)		RS1/16S104J
			R 2334(B,170,240)		RS1/16S104J
			R 2335(B,172,240)		RS1/16S104J

## COMPLEX ASSY (AWK8015)

### MISCELLANEOUS

△ Y 15	AWG18 BOARD IN	ADX7501
△ Y 14	AWG18 BOARD IN	ADX7500

## L DISPLAY ASSY

### MISCELLANEOUS

IC 2301(B,164,214)	DISPLAY U-COM	PE5503A			
IC 2402(A,237,230)	REMOTE RECEIVER UNIT	RPM7540-H9	R 2336(B,174,240)		RS1/16S104J
Q 2401(B,205,185)	TRANSISTOR	RT1N241M	R 2337(B,176,240)		RS1/16S104J
Q 2404(B,251,192)	TRANSISTOR	2SA1576A	R 2338(B,180,240)		RS1/16S473J
Q 2405(B,231,192)	TRANSISTOR	RT1N241M	R 2339(B,182,240)		RS1/16S473J
			R 2340(B,184,240)		RS1/16S473J
Q 2406(B,225,220)	DIGITAL TR(SC-70)	RT1N431M			
Q 2407(B,70,220)	DIGITAL TR(SC-70)	RT1N431M	R 2341(B,186,240)		RS1/16S473J
Q 2408(B,65,214)	DIGITAL TR(SC-70)	RT1N431M	R 2342(B,188,240)		RS1/16S473J
Q 2409(B,157,190)	DIGITAL TR(SC-70)	RT1N431M	R 2343(B,190,240)		RS1/16S473J
D 2404(B,238,190)	DIODE	1SS355	R 2344(B,192,240)		RS1/16S473J
			R 2345(B,194,240)		RS1/16S473J
D 2405(B,254,195)	DIODE	1SS355			
D 2406(B,252,209)	DIODE	DAN202U	R 2346(B,196,240)		RS1/16S473J
D 2408(A,237,220)	LED(RED)	SLI-343URW(RST)	R 2347(B,198,240)		RS1/16S473J
D 2410(A,76,218)	LED(ORANGE)	SLI-343DCW(STU)	R 2348(B,200,240)		RS1/16S473J
D 2412(A,58,214)	LED(RED)	SLI-343URW(RST)	R 2349(B,202,240)		RS1/16S473J
			R 2350(B,204,240)		RS1/16S473J
D 2414(A,157,197)	LED(BLUE)	SLR343BC4T(JKLM)			
D 2416(B,53,227)	DIODE	1SS355	R 2351(B,206,240)		RS1/16S473J
L 2401(A,248,205)	RADIAL INDUCTOR	LFCA2R2J	R 2352(B,208,240)		RS1/16S473J
V 2301(A,218,237)	FL TUBE DISPLAY	AAV7113	R 2353(B,210,240)		RS1/16S473J
X 2301(A,179,197)	CERAMIC RESONATOR	VSS1142	R 2354(B,198,200)		RS1/16S473J
			R 2355(B,206,191)		RS1/16S473J
CN2301(A,269,204)	CONNECTOR	CKS3394			
2303(A,267,196)	CABLE HOLDER(4P)	51063-0405	R 2356(B,190,207)		RS1/16S473J
2302(A,48,221)	17P CABLE HOLDER	51048-1700	R 2357(B,193,202)		RS1/16S473J
2301(A,157,201)	FL HOLDER(FE)	VNF1096	R 2358(B,181,201)		RS1/16S105J
			R 2359(B,176,202)		RS1/16S104J
			R 2361(B,172,197)		RS1/16S221J

### RESISTORS

R 2301(B,104,240)		RS1/16S104J	R 2362(B,170,194)		RS1/16S221J
R 2302(B,106,240)		RS1/16S104J	R 2363(B,169,194)		RS1/16S221J
R 2303(B,108,240)		RS1/16S104J	R 2364(B,167,194)		RS1/16S221J
R 2304(B,110,240)		RS1/16S104J	R 2366(B,162,198)		RS1/16S104J
R 2305(B,112,240)		RS1/16S104J	R 2368(B,126,199)		RS1/16S473J
R 2306(B,114,240)		RS1/16S104J	R 2369(B,131,208)		RS1/16S474J

**Mark No. Description****Part No.**

R 2370(B,114,207) RS1/16S221J  
 R 2371(B,136,208) RS1/16S104J  
 R 2372(B,135,208) RS1/16S221J  
 A R 2373(B,133,208) RS1/16S101J

R 2374(B,134,212) RS1/16S221J  
 R 2375(B,129,208) RS1/16S104J  
 R 2377(B,135,204) RS1/16S474J  
 R 2378(B,133,204) RS1/16S104J  
 R 2401(B,262,227) RS1/16S221J

R 2402(B,260,227) RS1/16S0R0J  
 R 2403(B,258,225) RS1/16S0R0J  
 R 2404(B,256,224) RS1/16S0R0J  
 R 2405(B,254,223) RS1/16S0R0J  
 R 2406(B,201,185) RS1/16S473J

B R 2411(B,247,191) RS1/16S0R0J  
 R 2412(B,249,192) RS1/16S104J  
 R 2413(B,240,191) RS1/16S472J  
 R 2414(B,237,196) RS1/16S0R0J  
 R 2415(B,257,192) RS1/16S104J

R 2416(B,251,195) RS1/16S103J  
 R 2417(B,239,196) RS1/16S102J  
 R 2419(B,232,240) RS1/16S101J  
 R 2420(B,233,220) RS1/16S331J  
 R 2421(B,72,225) RS1/16S331J

C R 2422(B,64,219) RS1/16S331J  
 R 2423(B,150,192) RS1/16S221J  
 R 2424(B,135,193) RS1/16S472J

**CAPACITORS**

C 2303(B,221,238) CKSRYB471K50  
 C 2304(A,230,236) ELECT. CAPACITOR CEAT101M35  
 C 2305(B,178,231) CKSRYB471K50  
 C 2306(B,180,231) CKSRYB471K50  
 C 2307(B,182,231) CKSRYB471K50

D C 2308(B,183,231) CKSRYB471K50  
 C 2309(B,187,231) CKSRYB471K50  
 C 2310(B,189,231) CKSRYB471K50  
 C 2311(B,190,231) CKSRYB471K50  
 C 2312(B,192,231) CKSRYB471K50

C 2313(B,196,231) CKSRYB471K50  
 C 2314(B,197,231) CKSRYB471K50  
 C 2315(B,199,231) CKSRYB471K50  
 C 2316(B,201,231) CKSRYB471K50  
 C 2317(B,204,231) CKSRYB471K50

E C 2318(B,206,231) CKSRYB471K50  
 C 2319(B,208,231) CKSRYB471K50  
 C 2320(B,209,231) CKSRYB471K50  
 C 2351(B,180,215) CKSRYB103K50  
 C 2353(B,185,207) CKSRYB104K25

C 2354(B,175,202) CKSRYB104K25  
 C 2359(B,142,204) CKSRYB103K50  
 C 2360(A,87,231) ELECT. CAPACITOR CEJQ470M50  
 C 2361(B,161,230) CKSRYB103K50  
 C 2362(B,160,230) CKSRYB103K50

F C 2403(B,247,195) CKSRYB103K50  
 C 2404(B,237,236) CKSRYB103K50  
 C 2405(A,247,235) CEJQ101M6R3  
 C 2406(B,245,209) CKSRYB103K50  
 C 2407(A,229,210) CEJQ221M6R3

**Mark No. Description****Part No.****M VOLUME ASSY  
MISCELLANEOUS**

J 2451 JUMPER WIRE D15A04-100-2651  
 S 2451(A,289,207) SWITCH VSG1024  
 S 2452(A,304,207) SWITCH VSG1024  
 S 2453(A,314,207) SWITCH VSG1024  
 S 2454(A,302,174) ROTARY ENCODER ASX7048

2451(A,278,202) CABLE HOLDER(4P) 51063-0405

**RESISTORS**

R 2451(B,296,206) RS1/16S681J  
 R 2452(B,311,206) RS1/16S821J

**CAPACITORS**

C 2451(B,281,208) CKSRYB102K50  
 C 2452(B,304,186) CKSRYB103K50  
 C 2453(B,299,186) CKSRYB103K50

**N MULTI JOG ASSY  
MISCELLANEOUS**

IC 2501(B,157,111) CMOS IC TC4094BF  
 Q 2501(B,162,146) DIGITAL TR(SC-70) RT1N431M  
 Q 2502(B,174,146) DIGITAL TR(SC-70) RT1N431M  
 Q 2503(B,195,146) DIGITAL TR(SC-70) RT1N431M  
 Q 2504(B,217,146) DIGITAL TR(SC-70) RT1N431M

Q 2505(B,237,147) DIGITAL TR(SC-70) RT1N431M  
 Q 2506(B,259,146) DIGITAL TR(SC-70) RT1N431M  
 Q 2507(B,280,146) DIGITAL TR(SC-70) RT1N431M  
 Q 2508(B,314,140) DIGITAL TR(SC-70) RT1N431M  
 Q 2509(B,131,147) DIGITAL TR(SC-70) RT1N431M

Q 2510(B,22,184) DIGITAL TR(SC-70) RT1N431M  
 Q 2511(B,121,147) DIGITAL TR(SC-70) RT1N431M  
 Q 2512(B,87,146) DIGITAL TR(SC-70) RT1N431M  
 D 2502(A,155,147) LED(ORANGE) SLR-343DC(NPQ)  
 D 2504(A,177,147) LED(ORANGE) SLR-343DC(NPQ)

D 2506(A,198,147) LED(ORANGE) SLR-343DC(NPQ)  
 D 2508(A,220,147) LED(ORANGE) SLR-343DC(NPQ)  
 D 2510(A,241,147) LED(ORANGE) SLR-343DC(NPQ)  
 D 2512(A,263,147) LED(ORANGE) SLR-343DC(NPQ)  
 D 2514(A,284,147) LED(ORANGE) SLR-343DC(NPQ)

D 2516(A,306,147) LED(ORANGE) SLR-343DC(NPQ)  
 D 2518(A,134,147) LED(ORANGE) SLR-343DC(NPQ)  
 D 2520(A,16,186) LED(BLUE) SLR343BC4T(JKLM)  
 D 2522(A,112,147) LED(ORANGE) SLR-343DC(NPQ)  
 D 2524(A,91,147) LED(ORANGE) SLR-343DC(NPQ)

J 2501 JUMPER WIRE D20PDD1715E  
 S 2501(A,36,119) ROTARY ENCODER ASX7031  
 S 2551(A,154,141) SWITCH VSG1024  
 S 2552(A,181,141) SWITCH VSG1024  
 S 2553(A,202,141) SWITCH VSG1024

S 2554(A,224,141) SWITCH VSG1024  
 S 2555(A,245,141) SWITCH VSG1024  
 S 2556(A,267,141) SWITCH VSG1024  
 S 2557(A,288,141) SWITCH VSG1024  
 S 2558(A,310,141) SWITCH VSG1024

S 2561(A,74,117) SWITCH VSG1024  
 S 2562(A,106,91) SWITCH VSG1024  
 S 2563(A,120,91) SWITCH VSG1024

Mark No.	Description	Part No.
S 2564(A,135,91)	SWITCH	VSG1024
S 2565(A,150,91)	SWITCH	VSG1024
S 2566(A,165,91)	SWITCH	VSG1024
S 2567(A,179,91)	SWITCH	VSG1024
S 2571(A,15,179)	SWITCH	VSG1024
S 2572(A,18,142)	SWITCH	VSG1024
S 2573(A,33,142)	SWITCH	VSG1024
S 2574(A,48,142)	SWITCH	VSG1024
S 2575(A,90,141)	SWITCH	VSG1024
S 2576(A,116,141)	SWITCH	VSG1024
S 2577(A,138,141)	SWITCH	VSG1024
2501(A,41,205)	17P CABLE HOLDER	51048-1700

**RESISTORS**

R 2501(B,151,152)	RS1/16S181J
R 2502(B,184,152)	RS1/16S181J
R 2503(B,194,152)	RS1/16S181J
R 2504(B,216,152)	RS1/16S181J
R 2505(B,237,152)	RS1/16S181J

R 2506(B,259,152)	RS1/16S181J
R 2507(B,280,152)	RS1/16S181J
R 2508(B,302,152)	RS1/16S181J
R 2509(B,142,152)	RS1/16S181J
R 2510(B,9,186)	RS1/16S391J

R 2511(B,119,152)	RS1/16S181J
R 2512(B,87,151)	RS1/16S181J
R 2513(B,160,103)	RS1/16S0R0J
R 2551(B,149,141)	RS1/16S472J
R 2552(B,173,141)	RS1/16S681J

R 2553(B,194,141)	RS1/16S821J
R 2554(B,216,141)	RS1/16S122J
R 2555(B,237,141)	RS1/16S162J
R 2556(B,258,141)	RS1/16S272J
R 2557(B,280,141)	RS1/16S512J

R 2558(B,301,142)	RS1/16S133J
R 2561(B,77,113)	RS1/16S472J
R 2562(B,106,98)	RS1/16S681J
R 2563(B,117,90)	RS1/16S821J
R 2564(B,132,90)	RS1/16S122J

R 2565(B,145,90)	RS1/16S162J
R 2566(B,160,90)	RS1/16S272J
R 2567(B,175,90)	RS1/16S512J
R 2571(B,12,181)	RS1/16S472J
R 2572(B,18,146)	RS1/16S681J

R 2573(B,30,142)	RS1/16S821J
R 2574(B,45,142)	RS1/16S122J
R 2575(B,87,141)	RS1/16S162J
R 2576(B,106,143)	RS1/16S272J
R 2577(B,130,141)	RS1/16S512J

R 2580(B,145,116)	RS1/16S561J
-------------------	-------------

**CAPACITORS**

C 2501(B,148,108)	CKSRYB103K50
C 2502(B,36,129)	CKSRYB103K50
C 2503(B,33,129)	CKSRYB103K50
C 2551(B,151,141)	CKSRYB102K50
C 2561(B,79,113)	CKSRYB102K50

C 2571(B,18,181)	CKSRYB102K50
C 2580(B,148,113)	CCSRCH561J50

Mark No.	Description	Part No.
----------	-------------	----------

**O HEADPHONE ASSY  
MISCELLANEOUS**

KN2851(A,13,54)	WRAPPING TERMINAL	VNF1084
CN2851(A,19,70)	4P JUMPER CONNECTOR	52147-0410
2851(A,15,14)	PHONE JACK	AKN7029

**RESISTORS**

R 2851(B,20,26)	RS1/16S102J
R 2852(B,16,27)	RS1/16S0R0J

**CAPACITORS**

C 2851(B,19,42)	CKSRYB392K50
C 2852(B,11,29)	CKSRYB392K50
C 2853(B,10,40)	CCSRCH471J50
C 2854(B,13,43)	CKSRYB103K50
C 2855(B,13,45)	CKSRYB104K16

**P FRONT-IN ASSY  
MISCELLANEOUS**

IC 2701(B,36,55)	OP-AMP IC	BA4560RF
Q 2651(B,116,47)	CHIP TRANSISTOR	HN1C01FU
D 2701(B,29,62)	DIODE	DAN217
D 2702(B,33,32)	DIODE	UDZS5R1(B)
D 2703(B,31,29)	DIODE	UDZS5R1(B)

D 2704(B,28,46)	DIODE	UDZS5R1(B)
L 2653(B,117,59)	INDUCTOR	CTF1385
L 2671(B,143,58)	INDUCTOR	CTF1385
L 2681(B,92,65)	CHIP SOLID INDUCTOR	QTL1013
L 2752(B,68,60)	CHIP FERRITE BEADS	VTL1169

L 2753(B,72,55)	CHIP FERRITE BEADS	VTL1169
JA 2651(A,109,69)	PIN JACK(4P)	XKX3003
JA 2652(A,88,77)	OPTICAL IN MOD.	GP1FMV51RK0F
JA 2701(A,45,73)	JACK REMOCON	RKN1004
JA 2751(A,65,76)	USB CONNECTOR	XKP3086

KN 2651(A,156,42)	WRAPPING TERMINAL	VNF1084
KN 3351(A,44,37)	WRAPPING TERMINAL	VNF1084
CN2651(A,40,28)	CONNECTOR	CKS3382
CN2652(A,67,42)	CONNECTOR	B4B-PH

**RESISTORS**

R 2651(B,121,58)	RS1/16S0R0J
R 2652(B,107,57)	RS1/16S0R0J
R 2653(B,128,58)	RS1/16S104J
R 2654(B,111,56)	RS1/16S104J
R 2655(B,128,54)	RS1/16S221J

R 2656(B,107,52)	RS1/16S221J
R 2657(B,124,54)	RS1/16S104J
R 2658(B,113,56)	RS1/16S104J
R 2659(B,122,46)	RS1/16S221J
R 2660(B,113,51)	RS1/16S221J

R 2661(B,118,46)	RS1/16S153J
R 2662(B,113,43)	RS1/16S153J
R 2663(B,120,46)	RS1/16S101J
R 2664(B,112,48)	RS1/16S101J
R 2665(B,100,46)	RS1/16S470J

R 2666(B,100,39)	RS1/16S470J
R 2668(B,131,57)	RS1/16S0R0J
R 2671(B,141,62)	RS1/16S750J
R 2672(B,145,62)	RS1/16S0R0J

**Mark No. Description****Part No.**

R	2673(B,152,59)	RS1/16S750J
R	2674(B,150,64)	RS1/16S750J
R	2675(B,152,55)	RS1/16S0R0J
R	2676(B,148,58)	RS1/16S0R0J
R	2681(B,85,65)	RS1/16S101J
R	2701(B,41,65)	RS1/16S102J
R	2702(B,38,68)	RS1/16S682J
R	2703(B,40,69)	RS1/16S104J
R	2704(B,30,66)	RS1/16S101J
R	2705(B,34,62)	RS1/16S104J
R	2706(B,30,57)	RS1/16S472J
R	2707(B,38,62)	RS1/16S333J
R	2708(B,41,61)	RS1/16S101J
R	2709(B,30,48)	RS1/16S472J
R	2710(B,34,48)	RS1/16S333J
R	2711(B,36,48)	RS1/16S101J
R	2712(B,34,28)	RS1/16S104J
R	2714(B,34,38)	RS1/16S102J
R	2751(B,65,60)	RS1/16S0R0J
R	2752(B,63,60)	RS1/16S0R0J

**CAPACITORS**

C	2651(B,126,58)	CCSRCH221J50
C	2652(B,109,56)	CCSRCH221J50
C	2653(A,125,47)	CEAT100M50
C	2654(A,109,46)	CEAT100M50
C	2655(B,126,54)	CCSRCH101J50

C	2656(B,115,56)	CCSRCH101J50
C	2659(A,125,39) ELECT. CAPACITOR	CEAT470M25
C	2660(A,109,39) ELECT. CAPACITOR	CEAT470M25
C	2661(B,113,40)	CKSRYB103K50
C	2662(B,115,37)	CKSRYB103K50

C	2663(A,102,46) ELECT. CAPACITOR	CEAT330M25
C	2664(A,102,40) ELECT. CAPACITOR	CEAT330M25
C	2665(B,152,46)	CKSRYB103K50
C	2666(B,150,46)	CKSRYB223K50
C	2671(B,130,61)	CKSRYB103K50

C	2673(B,154,57)	CKSRYB104K16
C	2674(B,156,46)	CKSRYB103K50
C	2675(B,158,46)	CKSRYB223K50
C	2681(B,89,65)	CKSRYB104K16
C	2701(B,42,69)	CCSRCH471J50

C	2702(A,36,66)	CEAT100M50
C	2703(B,32,62)	CCSRCH101J50
C	2704(B,36,62)	CCSRCH330J50
C	2705(B,32,48)	CCSRCH330J50
C	2706(A,34,36)	CEAT100M50

C	2707(B,48,43)	CKSRYB103K50
C	2709(B,52,43)	CKSRYB223K50
C	2712(A,35,44)	CEAT100M50
C	2713(B,40,57)	CKSRYB103K50
C	2714(B,40,53)	CKSRYB103K50

C	2715(A,49,59)	CEAT100M50
C	2716(A,49,53)	CEAT100M50
C	2718(B,40,38)	CKSRYB102K50
C	2719(B,40,36)	CCSRCH221J50
C	2753(B,68,56)	CKSRYB104K16

C	2755(A,68,51)	CEAT101M16
C	2756(B,73,51)	CKSRYB104K16
C	2757(B,73,46)	CCSRCH471J50

**Mark No. Description****Part No.**

<b>Q</b>	<b>PRIMARY ASSY</b>	
	<b>MISCELLANEOUS</b>	
△ IC	2001(A,305,99) REGULATOR IC	NJM78M56FA
Q	2001(B,281,60) DIGITAL TR(SC-70)	RT1N431M
D	2001(B,276,60) DIODE	1SS355
D	2002(B,276,65) DIODE	1SS355
△ D	2003(B,296,87) BRIDGE DIODE	S1WB(A)60SD
D	2004(B,304,75) DIODE	1SS355
D	2006(B,308,70) DIODE	UDZS5R1(B)
△ L	2001(A,244,24) LINE FILTER	XTF3004
H	2001(A,243,46) FUSE CLIP	AKR7001
H	2002(A,223,46) FUSE CLIP	AKR7001
KN	2001(A,194,19) SCREW PLATE	VNE1948
△ RY	2001(A,251,58) JOE LOWPOWER RELAY	ASR7013
△ T	2001(A,273,84) STANDBY TRANSFORMER	ATT7040
CN	2001(A,301,115) 9P SOCKET	KP200TA9L
CN	2002(A,246,115) 5P SOCKET	KP200TA5L
△ CN	2003(A,225,25) AC CODE SOCKET	RKP1751

**RESISTORS**

R	2002(A,279,68) CARBON FILM RESISTOR	RD1/4MUF101J
R	2003(B,305,70)	RS1/16S103J
R	2004(B,302,70)	RS1/16S332J

**CAPACITORS**

△ C	2002(A,266,26) FILM CAPACITOR	ACE7013
△ C	2003(A,251,52) SAFETY CAPACITOR	XCG3009
C	2004(A,290,106) FILM CAPACITOR	CQMBA103J50
C	2009(A,303,88) ELECT. CAPACITOR	CEAT332M25
C	2010(A,309,106)	CEAT221M25
C	2011(B,310,85)	CKSRYB103K50

**R TRANS 1 ASSY**

TRANS 1 ASSY has no service part.

**SECONDARY ASSY (AWK7911)****MISCELLANEOUS**

Y	9 AWG18 BOARD IN	ADX7502
Y	10 AWG18 BOARD IN	ADX7503
Y	11 AWG18 BOARD IN	ADX7504
Y	12 AWG18 BOARD IN	ADX7505

**S TRANS 2-1 ASSY****MISCELLANEOUS**

△ IC	3251(A,228,215) PROTECTOR(7A)	AEK7021
△ IC	3252(A,239,164) PROTECTOR(7A)	AEK7021
Q	3251(B,244,224) CHIP TRANSISTOR	RN1901
Q	3252(B,253,224) TRANSISTOR	UMD2N
Q	3253(B,261,224) TRANSISTOR	UMD2N
△ D	3251(B,234,181) BRIDGE DIODE	S1WB(A)60SD
D	3253(B,236,216) DIODE	UDZS8R2(B)
D	3254(B,263,217) DIODE	UDZS7R5(B)
D	3255(B,233,216) DIODE	UDZS9R1(B)
D	3256(B,263,219) DIODE	UDZS8R2(B)
D	3257(B,233,223) DIODE	UDZS9R1(B)
D	3258(B,258,218) DIODE	UDZS8R2(B)

Mark No.	Description	Part No.
D 3259(B,238,223)	DIODE	UDZS6R8(B)
D 3260(B,258,220)	DIODE	UDZS6R8(B)
D 3261(B,240,220)	DIODE	UDZS12(B)
D 3262(B,253,220)	DIODE	UDZS12(B)
D 3263(B,238,218)	DIODE	UDZS13(B)
D 3264(B,253,218)	DIODE	UDZS15(B)
D 3265(B,257,226)	DIODE	UDZS13(B)
D 3266(B,267,227)	DIODE	UDZS13(B)
J 3251 JUMPER WIRE		D20PDY0610E
3251(A,261,193)	6P CABLE HOLDER	51048-0600

### RESISTORS

⚠ R 3253(A,248,192)	METAL OXIDE RESISTOR	RS1LMF472J
⚠ R 3254(A,263,212)	METAL OXIDE RESISTOR	RS1LMF472J
⚠ R 3255(A,245,195)	CARBON FILM RESISTOR	RD1/2LMF332J
⚠ R 3256(A,259,215)	CARBON FILM RESISTOR	RD1/2LMF332J

### CAPACITORS

C 3253(A,243,186)	ELECT. CAPACITOR	CEAT471M2A
C 3254(A,253,172)	ELECT. CAPACITOR	CEAT471M2A
C 3255(A,240,202)	ELECT. CAPACITOR	CEAT101M63
C 3256(A,240,213)	ELECT. CAPACITOR	CEAT101M63
C 3257(A,269,190)	ELECT. CAPACITOR	CEAT221M2A
C 3258(A,262,201)	ELECT. CAPACITOR	CEAT221M2A

## T DIODE 1 ASSY

### MISCELLANEOUS

⚠ D 3301(A,175,164)	DIODE	D5SBA20(B)
⚠ D 3302(A,175,199)	DIODE	D5SBA20(B)

### RESISTORS

⚠ R 3301(A,194,172)	CARBON FILM RESISTOR	RD1/4MUF100J
---------------------	----------------------	--------------

### CAPACITORS

C 3301(A,191,182)	FILM CAPACITOR	CFTLA104J2A
C 3302(A,196,177)	FILM CAPACITOR	CFTLA104J2A

## U VH TR ASSY

### MISCELLANEOUS

⚠ IC 3351(A,177,136)	IC PROTECTOR	ICP-N15
⚠ IC 3352(A,177,152)	IC PROTECTOR	ICP-N15
⚠ Q 3351(B,172,130)	CHIP TRANSISTOR	2SA1514K
⚠ Q 3352(A,162,135)	TRANSISTOR	2SB1186A
⚠ Q 3353(A,162,150)	TRANSISTOR	2SD1763A
⚠ Q 3354(B,172,145)	CHIP TRANSISTOR	2SC3906K
⚠ D 3351(B,173,141)	DIODE	1SR154-400
⚠ D 3352(B,176,157)	DIODE	1SR154-400
CN3351(A,184,138)	6P JUMPER CONNECTOR	52147-0610

### RESISTORS

R 3351(B,179,129)	RS1/16S471J
R 3352(B,168,128)	RS1/16S100J
R 3353(B,168,143)	RS1/16S100J
R 3354(B,177,144)	RS1/16S471J

Mark No.	Description	Part No.
<b>V</b>	<b>BRIDGE 1 ASSY</b>	
	<b>MISCELLANEOUS</b>	
CN5811(A,46,130)	23P PLUG	XKP3071
CN5812(A,46,105)	23P PLUG	XKP3071
5811(A,8,101)	PCB BINDER	VEF1040

## W PS/SP ASSY

### MISCELLANEOUS

Q 3001(B,161,85)	CHIP TRANSISTOR	DTC114TUA
Q 3002(B,229,97)	CHIP TRANSISTOR	DTC114TUA
Q 3003(B,247,90)	CHIP TRANSISTOR	DTC114TUA
Q 3004(B,290,84)	CHIP TRANSISTOR	DTC114TUA
Q 3005(B,212,99)	CHIP TRANSISTOR	DTC114TUA

D 3001(B,168,80)	DIODE	1SS355
D 3002(B,165,80)	DIODE	1SS355
D 3003(B,216,88)	DIODE	1SS355
D 3004(B,213,88)	DIODE	1SS355
D 3005(B,247,82)	DIODE	1SS355

D 3006(B,244,82)	DIODE	1SS355
D 3007(B,291,79)	DIODE	1SS355
D 3008(B,289,79)	DIODE	1SS355
D 3009(B,217,99)	DIODE	1SS355
D 3010(B,215,99)	DIODE	1SS355

L 3011(A,188,78)	COIL	ATH1053
L 3021(A,146,69)	COIL	ATH1053
L 3031(A,199,83)	COIL	ATH1053
L 3041(A,258,82)	COIL	ATH1053
L 3051(A,236,90)	COIL	ATH1053

L 3061(A,299,74)	COIL	ATH1053
L 3071(A,280,84)	COIL	ATH1053
J 3009(A,174,89)	CONNECTOR ASSY	PF13PG-R07
KN 3001(A,318,64)	WRAPPING TERMINAL	VNF1084
RY 3001(A,163,81)	RELAY	ASR7001

RY 3002(A,211,89)	RELAY	ASR7001
RY 3003(A,242,83)	RELAY	ASR7001
RY 3004(A,286,82)	RELAY	ASR7001
RY 3005(A,219,103)	RELAY	ASR7001
CN3001(A,190,33)	SPEAKER TERMINAL 8-P	AKE7119

CN3002(A,274,33)	SPEAKER TERMINAL 6-P	AKE7108
CN3007(A,313,90)	5P PLUG 5P PLUG	KM200TA5
CN3008(A,313,145)	9P PLUG	KM200TA9
Y 13 AWG14 BOARD IN		ADX7512
Y 8 AWG14 BOARD IN		ADX7512

### RESISTORS

⚠ R 3011(A,187,68)	METAL OXIDE RESISTOR	RS1/2LMF4R7J
⚠ R 3012(A,175,64)	METAL OXIDE RESISTOR	RS1LMF100J
⚠ R 3013(A,193,94)	METAL OXIDE RESISTOR	RS2LMF331J
⚠ R 3021(A,148,79)	METAL OXIDE RESISTOR	RS1/2LMF4R7J
⚠ R 3022(A,152,51)	METAL OXIDE RESISTOR	RS1LMF100J

⚠ R 3023(A,188,97)	METAL OXIDE RESISTOR	RS2LMF331J
⚠ R 3031(A,196,87)	METAL OXIDE RESISTOR	RS1/2LMF4R7J
⚠ R 3032(A,194,67)	METAL OXIDE RESISTOR	RS1LMF100J
⚠ R 3041(A,254,82)	METAL OXIDE RESISTOR	RS1/2LMF4R7J
⚠ R 3042(A,267,67)	METAL OXIDE RESISTOR	RS1LMF100J

⚠ R 3051(A,240,93)	METAL OXIDE RESISTOR	RS1/2LMF4R7J
⚠ R 3052(A,237,79)	METAL OXIDE RESISTOR	RS1LMF100J
⚠ R 3061(A,309,63)	METAL OXIDE RESISTOR	RS1/2LMF4R7J
⚠ R 3062(A,313,73)	METAL OXIDE RESISTOR	RS1LMF100J

Mark No.	Description	Part No.
△ R 3071(A,280,88)	METAL OXIDE RESISTOR	RS1/2LMF4R7J
△ R 3072(A,268,94)	METAL OXIDE RESISTOR	RS1LMF100J
△ R 3101(A,222,115)	CARBON FILM RESISTOR	RD1/4MUF473J
△ R 3102(A,252,115)	CARBON FILM RESISTOR	RD1/4MUF473J

### CAPACITORS

C 3001(A,164,89)		CEAT101M50
C 3011(A,190,60)		CFTLA104J50
C 3012(A,203,53)		CFTLA104J50
C 3013(A,190,42)	FILM CAPACITOR	CQMBA103J50
C 3021(A,157,48)		CFTLA104J50
C 3022(A,157,39)		CFTLA104J50
C 3023(A,169,42)	FILM CAPACITOR	CQMBA103J50
C 3031(A,205,66)		CFTLA104J50
C 3032(A,200,60)		CFTLA104J50
C 3033(A,211,42)	FILM CAPACITOR	CQMBA103J50
C 3041(A,257,63)		CFTLA104J50
C 3042(A,253,57)		CFTLA104J50
C 3043(A,253,42)	FILM CAPACITOR	CQMBA103J50
C 3051(A,224,70)		CFTLA104J50
C 3052(A,230,70)		CFTLA104J50
C 3053(A,232,42)	FILM CAPACITOR	CQMBA103J50
C 3061(A,308,58)		CFTLA104J50
C 3062(A,302,53)		CFTLA104J50
C 3063(A,295,42)	FILM CAPACITOR	CQMBA103J50
C 3071(A,274,70)		CFTLA104J50
C 3072(A,279,65)		CFTLA104J50
C 3073(A,274,42)	FILM CAPACITOR	CQMBA103J50
C 3091(B,181,50)		CKSRYB222K50
C 3092(B,179,50)		CKSRYB222K50
C 3093(B,265,50)		CKSRYB222K50
C 3094(B,263,50)		CKSRYB222K50
C 3096(B,318,55)		CKSRYB222K50
C 3101(A,212,137)		ACH7255
C 3102(A,258,137)		ACH7255

### X TRANS 2-2 ASSY

#### MISCELLANEOUS

H 3401(A,120,100)	FUSE CLIP	AKR7001
H 3402(A,98,100)	FUSE CLIP	AKR7001
H 3403(A,120,87)	FUSE CLIP	AKR7001
H 3404(A,98,87)	FUSE CLIP	AKR7001
H 3405(A,120,74)	FUSE CLIP	AKR7001
H 3406(A,98,74)	FUSE CLIP	AKR7001
H 3407(A,119,57)	FUSE CLIP	AKR7001
H 3408(A,97,57)	FUSE CLIP	AKR7001
H 3409(A,120,45)	FUSE CLIP	AKR7001
H 3410(A,98,45)	FUSE CLIP	AKR7001
J 3401(A,132,97)	CONNECTOR ASS'Y	PF12PG-R40

### Y TRANS SIDE ASSY

#### MISCELLANEOUS

J 3201	JUMPER WIRE	D20PDY0410E
CN3202(A,60,8)	CONNECTOR	CKS3382
CN3203(A,319,21)	CONNECTOR	B13B-PH
3201(A,84,28)	4P CABLE HOLDER	51048-0400

Mark No. Description Part No.

### Z LOCAL P-SUPPLY ASSY

#### MISCELLANEOUS

△ IC 3502(A,120,181)	PROTECTOR(1.6A)	AEK7012
△ IC 3504(A,80,176)	IC	NJM78M05FA
△ IC 3505(A,80,226)	REGULATOR IC	NJM78M56FA
△ IC 3506(A,80,201)	IC	NJM79M05FA
△ IC 3510(A,111,238)	PROTECTOR(1.6A)	AEK7012
△ Q 3501(B,110,149)	TRANSISTOR	UMD2N
△ Q 3502(A,80,151)	TRANSISTOR	2SD1763A
Q 3503(B,144,140)	DIGITAL TRANSISTOR	DTC124EUA
Q 3504(B,109,230)	CHIP TRANSISTOR	RSR015P03
Q 3505(B,115,232)	DIGITAL TRANSISTOR	DTC124EUA
△ D 3501(B,120,163)	DIODE	1SR154-400
△ D 3502(B,124,163)	DIODE	1SR154-400
△ D 3503(B,128,163)	DIODE	1SR154-400
D 3504(B,136,146)	DIODE	UDZS6R2(B)
D 3505(B,138,146)	DIODE	UDZS6R2(B)
D 3506(B,141,146)	DIODE	UDZS6R2(B)
D 3507(B,143,146)	DIODE	UDZS6R2(B)
D 3508(B,142,180)	DIODE	UDZS6R2(B)
△ D 3509(B,108,160)	DIODE	1SR154-400
△ D 3510(B,113,160)	DIODE	1SR154-400
D 3511(B,106,137)	DIODE	UDZS27(B)
△ D 3512(A,117,196)	DIODE	D3SBA20(B)
D 3513(B,86,180)	CHIP DIODE	RB501V-40
△ D 3514(A,95,181)	DIODE	MTZJ6R2(B)
D 3515(B,87,236)	CHIP DIODE	RB501V-40
D 3516(B,87,204)	CHIP DIODE	RB501V-40
D 3529(B,80,196)	DIODE	1SS355
J 3502	9P JUMPER WIRE	D20PDY0915E
J 3503(A,152,132)	CONNECTOR ASSY	PF05PG-Q15
J 3504(A,160,239)	CONNECTOR ASSY	PF10PG-R07
J 3505(A,138,232)	CONNECTOR ASSY	PF09PG-R37
J 3506	JUMPER WIRE	D20PDY0410E
CN3501(A,141,151)	CONNECTOR	B12B-PH
3502(A,149,215)	9P CABLE HOLDER	51048-0900
3506(A,150,167)	4P CABLE HOLDER	51048-0400

#### RESISTORS

R 3501(B,120,152)		RS1/16S473J
△ R 3503(A,127,156)	CARBON FILM RESISTOR	RD1/4MUF391J
R 3504(B,111,142)		RS1/16S472J
R 3505(B,108,142)		RS1/16S101J
R 3506(B,140,139)		RS1/16S222J
△ R 3508(A,134,181)	CARBON FILM RESISTOR	RD1/4MUF4R7J
R 3511(B,106,235)		RS1/16S103J
R 3512(B,113,235)		RS1/16S101J

#### CAPACITORS

C 3501(A,150,148)	FILM CAPACITOR	CQMBA104J50
C 3502(A,122,168)	ELECT. CAPACITOR	CEANP101M35
C 3503(A,118,157)	ELECT. CAPACITOR	CEAT101M35
C 3504(A,123,147)		CEAT221M35
C 3505(A,139,179)		CEAT101M16
C 3506(A,133,145)		CEAT470M50
C 3508(B,122,152)		CKSRYB103K50
C 3510(A,110,171)	ELECT. CAPACITOR	CEANP102M16
C 3511(A,107,154)	ELECT. CAPACITOR	CEAT102M35
C 3512(A,112,133)		CEAT100M50

Mark No.	Description	Part No.
C 3513(B,83,149)		CKSRYB102K50
C 3514(A,145,136)		CEAT100M50
C 3515(A,137,140)	ELECT. CAPACITOR	CEANP470M25
C 3516(A,122,187)	FILM CAPACITOR	CQMBA104J50
C 3517(B,83,175)		CKSRYB103K50
C 3518(A,85,189)		CEAT221M16
C 3519(A,117,208)	ELECT. CAPACITOR	CEAT682M16
C 3520(A,134,208)	ELECT. CAPACITOR	CEAT222M16
C 3521(B,83,224)		CKSRYB103K50
C 3522(B,87,201)		CKSRYB103K50
C 3523(A,88,227)		CEAT101M16
C 3524(A,85,214)		CEAT101M16

## AA DC/DC ASSY

### MISCELLANEOUS

⚠ IC 651 (A,43,196)	REGULATOR IC	PQ1CG3032FZ
⚠ Q 651 (A,65,206)	TRANSISTOR	2SD1858X
D 651 (B,45,207)	DIODE	RB051L-40
D 652 (B,66,211)	DIODE	UDZS7R5(B)
⚠ D 653 (A,38,152)	DIODE	D3SBA20(B)
⚠ D 654 (A,68,231)	DIODE	MTZJ6R2(B)
L 651 (A,50,212)	INDUCTOR	ATH7020
KN651 (A,40,181)	SCREW PLATE	VNE1948
CN651 (A,70,221)	3P TOP POST	B3B-EH
CN652 (A,70,166)	4P JUMPER CONNECTOR	52147-0410
651 (A,52,146)	PCB BINDER	VEF1040

### RESISTORS

⚠ R 651 (A,64,164)	CARBON FILM RESISTOR	RD1/4MUF4R7J
R 652 (B,39,194)	CHIP METAL FILM R	RN1/16SE1800D
R 653 (B,38,195)		RN1/16SE3001D
R 654 (B,41,192)		RN1/16SE1001D
R 655 (B,64,210)		RS1/16S302J
R 656 (B,62,210)		RS1/16S101J

### CAPACITORS

C 651 (A,68,150)	FILM CAPACITOR	CQMBA104J50
C 654 (A,59,176)	ELECT. CAPACITOR	CEAT103M16
C 655 (A,67,189)	ELECT. CAPACITOR	CEHAZL102M16
C 657 (A,55,226)	ELECT. CAPACITOR	CEHAZL102M6R3
C 658 (A,67,214)		CEAT101M16
C 659 (A,69,206)		CEAT101M16

## AB IR I/O ASSY

### MISCELLANEOUS

⚠ Q 3751(B,34,66)	TRANSISTOR	2SD1664
D 3752(B,41,60)	DIODE	UDZS10(B)
KN3751(A,40,91)	SCREW PLATE	VNE1948
CN3701(A,58,46)	10P CONNECTOR	VKN1241
CN3702(A,74,44)	23P SOCKET	XKP3082
CN3703(A,28,43)	CONNECTOR	CKS3376

### RESISTORS

R 3703(B,25,84)		RS1/16S0R0J
R 3752(A,38,66)	CARBON FILM RESISTOR	RD1/4MUF391J
R 3755(B,48,62)		RS1/16S0R0J

Mark No.	Description	Part No.
<b>CAPACITORS</b>		
C 3701(B,49,81)		CKSRYB104K50
C 3702(B,27,84)		CCSRCH471J50
C 3752(A,38,61)		CEAT101M16
C 3753(B,26,71)		CKSRYB103K50
C 3754(B,24,71)		CKSRYB104K50
C 3755(B,28,71)		CKSRYB105K10
C 3756(B,67,56)		CKSRYB103K50
C 3757(B,71,58)		CCSRCH471J50

## AC VIDEO CONNECT ASSY

### MISCELLANEOUS

CN3801(A,288,240)	CONNECTOR POST	S9B-PH
CN3802(A,298,175)	21P PLUG	XKP3070
CN3803(A,305,198)	15P PLUG	XKP3067
CN3804(A,308,222)	13P PLUG	XKP3066

## POWER AMP ASSY (AWK7920)

### MISCELLANEOUS

J 3	JUMPER WIRE	D20PDY0525E
Y 5	LEAD WITH HOUSING	ADX7404
Y 4	LEAD WITH HOUSING	ADX7460
Y 3	LEAD WITH HOUSING	ADX7458
Y 2	LEAD WITH HOUSING	ADX7457
Y 1	LEAD WITH HOUSING	ADX7459
Y 6	LEAD WITH HOUSING	ADX7498

## AD POWER AMP-L ASSY

### MISCELLANEOUS

⚠ IC 5001(A,174,135)	DARLINGTON POWER IC	SAP17N(OY)
⚠ IC 5002(A,208,135)	DARLINGTON POWER IC	SAP17P(OY)
⚠ IC 5101(A,106,135)	DARLINGTON POWER IC	SAP17N(OY)
⚠ IC 5102(A,140,135)	DARLINGTON POWER IC	SAP17P(OY)
⚠ IC 5201(A,242,135)	DARLINGTON POWER IC	SAP17N(OY)
⚠ IC 5202(A,276,135)	DARLINGTON POWER IC	SAP17P(OY)
⚠ IC 5601(A,310,135)	DARLINGTON POWER IC	SAP17N(OY)
Q 5001(B,186,207)	CHIP TRANSISTOR	2SD2704K
Q 5002(B,174,194)	TRANSISTOR	IMT4
Q 5003(B,188,198)	CHIP TRANSISTOR	2SA1514K
⚠ Q 5004(A,185,184)	TRANSISTOR	2SA1145
Q 5005(A,161,191)	TRANSISTOR	2SC2705
Q 5041(B,149,195)	CHIP TR	2SA1255
Q 5101(B,132,207)	CHIP TRANSISTOR	2SD2704K
Q 5102(B,120,194)	TRANSISTOR	IMT4
Q 5103(B,134,198)	CHIP TRANSISTOR	2SA1514K
⚠ Q 5104(A,131,184)	TRANSISTOR	2SA1145
Q 5105(A,108,191)	TRANSISTOR	2SC2705
Q 5141(B,91,201)	CHIP TR	2SA1255
Q 5201(B,274,206)	CHIP TRANSISTOR	2SD2704K
Q 5202(B,262,193)	TRANSISTOR	IMT4
Q 5203(B,276,197)	CHIP TRANSISTOR	2SA1514K
⚠ Q 5204(A,273,183)	TRANSISTOR	2SA1145
Q 5205(A,250,191)	TRANSISTOR	2SC2705
Q 5241(B,238,197)	CHIP TR	2SA1255

⚠ D 5001(B,190,188)	CHIP ZENER DIODE	UDZS3R6(B)
⚠ D 5002(B,188,188)	DIODE	1SS355
⚠ D 5003(B,180,184)	DIODE	1SS355



Mark No.	Description	Part No.
△ R 5225(B,238,156)	CHIP RESISTOR	ACN7132
△ R 5226(B,276,156)	CHIP RESISTOR	ACN7132
△ R 5227(A,274,165)	RESISTOR (0.18, 5W)	ACN7121
R 5229(B,255,202)		RN1/10SE3302D
R 5230(B,261,202)		RN1/16SE1001D
R 5231(B,261,204)		RN1/16SE1500D
R 5232(B,248,195)		RS1/16S151J
R 5241(B,237,169)		RS1/16S473J
R 5242(B,239,169)		RS1/16S223J
R 5243(B,235,169)		RS1/16S471J
R 5244(B,241,169)		RS1/16S471J
R 5245(B,240,180)		RS1/16S472J
R 5246(B,242,180)		RS1/16S472J
R 5247(B,240,189)		RS1/16S122J
R 5248(B,237,180)		RS1/16S154J
R 5249(B,242,184)		RS1/16S103J
R 5250(B,240,184)		RS1/16S103J
△ R 5292(B,300,156)	CHIP RESISTOR	ACN7132
△ R 5613(B,317,154)		RS1/16S330J
R 5621(B,312,154)		RS1/16S101J

**CAPACITORS**

C 5001(A,183,203)		CEAT4R7M50
C 5002(B,177,200)		CCSRCH221J50
C 5004(B,167,194)		CKSRYB102K50
C 5007(A,195,193)		CEAT101M10
C 5008(B,164,195)	CAPACITOR(CERAMIC)	ACG7057
C 5009(A,179,189)	ELECT. CAPACITOR	CEAT100M2A
C 5011(B,169,142)	CAPACITOR(CERAMIC)	ACG7056
C 5012(B,197,142)	CAPACITOR(CERAMIC)	ACG7056
C 5015(B,168,205)		CCSRCH220J50
C 5016(B,168,207)		CCSRCH220J50
C 5017(A,172,207)		CEAT331M10
C 5023(A,190,180)		CEAT100M63
C 5024(A,166,184)		CEAT100M63
C 5032(B,162,199)		CKSRYB224K16
C 5041(A,147,190)		CEANP2R2M50
C 5051(A,217,183)	ELECT. CAPACITOR	CEAT100M2A
C 5052(A,222,177)	ELECT. CAPACITOR	CEAT100M2A
C 5101(A,129,203)		CEAT4R7M50
C 5102(B,123,200)		CCSRCH221J50
C 5104(B,113,194)		CKSRYB102K50
C 5107(A,141,193)		CEAT101M10
C 5108(B,111,195)	CAPACITOR(CERAMIC)	ACG7057
C 5109(A,125,189)	ELECT. CAPACITOR	CEAT100M2A
C 5111(B,101,142)	CAPACITOR(CERAMIC)	ACG7056
C 5112(B,130,142)	CAPACITOR(CERAMIC)	ACG7056
C 5115(B,115,205)		CCSRCH220J50
C 5116(B,115,207)		CCSRCH220J50
C 5117(A,119,207)		CEAT331M10
C 5123(A,137,180)		CEAT100M63
C 5124(A,112,184)		CEAT100M63
C 5132(B,108,199)		CKSRYB224K16
C 5141(A,88,191)		CEANP2R2M50
C 5201(A,271,202)		CEAT4R7M50
C 5202(B,265,199)		CCSRCH221J50
C 5204(B,255,194)		CKSRYB102K50
C 5207(A,283,192)		CEAT101M10
C 5208(B,253,195)	CAPACITOR(CERAMIC)	ACG7057
C 5209(A,267,187)	ELECT. CAPACITOR	CEAT100M2A

Mark No.	Description	Part No.
C 5211(B,243,142)	CAPACITOR(CERAMIC)	ACG7056
C 5212(B,271,142)	CAPACITOR(CERAMIC)	ACG7056
C 5215(B,257,204)		CCSRCH220J50
C 5216(B,257,206)		CCSRCH220J50
C 5217(A,261,206)		CEAT331M10
C 5223(A,287,181)		CEAT100M63
C 5224(A,255,184)		CEAT100M63
C 5232(B,250,199)		CKSRYB224K16
C 5241(A,237,192)		CEANP2R2M50
C 5611(B,307,142)	CAPACITOR(CERAMIC)	ACG7056

**AE POSI 1-L ASSY MISCELLANEOUS**

△ TH 4501(A,54,223)	POSISTOR	PTFM04BH222Q2N34B0
J 4501(A,66,220)	CONNECTOR ASSY	PG02KS-E07

**AF POSI 2-L ASSY MISCELLANEOUS**

△ TH 4502(A,79,235)	POSISTOR	PTFM04BC222Q2N34B0
J 4502(A,76,223)	CONNECTOR ASSY	PG02KS2E07

**AG POWER AMP-R ASSY MISCELLANEOUS**

△ IC 5301(A,196,111)	DARLINGTON POWER IC	SAP17N(OY)
△ IC 5302(A,162,111)	DARLINGTON POWER IC	SAP17P(OY)
△ IC 5401(A,128,111)	DARLINGTON POWER IC	SAP17N(OY)
△ IC 5402(A,94,111)	DARLINGTON POWER IC	SAP17P(OY)
△ IC 5501(A,264,111)	DARLINGTON POWER IC	SAP17N(OY)
△ IC 5502(A,230,111)	DARLINGTON POWER IC	SAP17P(OY)
△ IC 5602(A,298,111)	DARLINGTON POWER IC	SAP17P(OY)
Q 5301(B,186,38)	CHIP TRANSISTOR	2SD2704K
Q 5302(B,176,52)	TRANSISTOR	IMT4
Q 5303(B,187,48)	CHIP TRANSISTOR	2SA1514K
△ Q 5304(A,185,62)	TRANSISTOR	2SA1145
Q 5305(A,161,55)	TRANSISTOR	2SC2705
Q 5341(B,146,56)	CHIP TR	2SA1255
Q 5401(B,132,38)	CHIP TRANSISTOR	2SD2704K
Q 5402(B,122,52)	TRANSISTOR	IMT4
Q 5403(B,133,48)	CHIP TRANSISTOR	2SA1514K
△ Q 5404(A,131,62)	TRANSISTOR	2SA1145
Q 5405(A,108,55)	TRANSISTOR	2SC2705
Q 5441(B,91,45)	CHIP TR	2SA1255
Q 5501(B,275,38)	CHIP TRANSISTOR	2SD2704K
Q 5502(B,266,52)	TRANSISTOR	IMT4
Q 5503(B,277,48)	CHIP TRANSISTOR	2SA1514K
△ Q 5504(A,274,63)	TRANSISTOR	2SA1145
Q 5505(A,252,55)	TRANSISTOR	2SC2705
Q 5541(B,239,49)	CHIP TR	2SA1255
Q 5571(B,223,38)	TRANSISTOR	2SC4081
Q 5572(B,220,38)	TRANSISTOR	2SC4081
△ D 5301(B,191,58)	CHIP ZENER DIODE	UDZS3R6(B)
△ D 5302(B,188,58)	DIODE	1SS355
△ D 5303(B,180,62)	DIODE	1SS355
△ D 5304(B,173,62)	DIODE	1SS355
△ D 5305(B,177,62)	DIODE	UDZS4R7(B)
△ D 5306(B,175,62)	DIODE	UDZS4R7(B)
D 5341(B,151,71)	DIODE	1SS355

	<u>Mark No.</u>	<u>Description</u>	<u>Part No.</u>	<u>Mark No.</u>	<u>Description</u>	<u>Part No.</u>
	D	5342(B,149,71) DIODE	1SS355	R	5346(B,149,65)	RS1/16S472J
	D	5343(B,150,50) DIODE	1SS355	R	5347(B,145,62)	RS1/16S122J
A	D	5344(B,153,71) DIODE	1SS355	R	5348(B,148,61)	RS1/16S154J
	△D	5401(B,137,58) CHIP ZENER DIODE	UDZS3R6(B)	R	5349(B,150,61)	RS1/16S103J
	△D	5402(B,135,58) DIODE	1SS355	R	5350(B,150,55)	RS1/16S103J
	△D	5403(B,126,62) DIODE	1SS355	R	5401(B,139,43)	RS1/16S102J
	△D	5404(B,119,62) DIODE	1SS355	R	5402(B,126,42)	RS1/16S221J
	△D	5405(B,124,62) DIODE	UDZS4R7(B)	R	5403(B,123,41)	RS1/16S333J
	△D	5406(B,122,62) DIODE	UDZS4R7(B)	R	5404(B,139,40)	RS1/16S103J
	D	5441(B,95,58) DIODE	1SS355	R	5405(B,116,55)	RS1/16S152J
	D	5442(B,92,58) DIODE	1SS355	R	5406(B,114,47)	RS1/16S821J
	D	5443(B,94,41) DIODE	1SS355	R	5407(B,137,48)	RS1/16S2001F
	D	5444(B,97,58) DIODE	1SS355	R	5408(B,126,54)	RS1/16S682J
B	△D	5501(B,280,59) CHIP ZENER DIODE	UDZS3R6(B)	R	5409(A,129,48) CARBON FILM RESISTOR	RD1/2VM473J
	△D	5502(B,277,59) DIODE	1SS355	R	5410(B,137,62)	RS1/16S151J
	△D	5503(B,267,62) DIODE	1SS355	R	5411(B,135,62)	RN1/16SE1201D
	△D	5504(B,261,62) DIODE	1SS355	R	5412(B,109,51)	RS1/16S221J
	△D	5505(B,265,62) DIODE	UDZS4R7(B)	△R	5413(B,115,97)	RS1/16S330J
	△D	5506(B,263,62) DIODE	UDZS4R7(B)	R	5421(B,128,93)	RS1/16S101J
	D	5541(B,240,71) DIODE	1SS355	R	5422(B,108,93)	RS1/16S101J
	D	5542(B,238,71) DIODE	1SS355	△R	5423(A,138,80) CARBON FILM RESISTOR	RD1/4MUF4R7J
	D	5543(B,240,45) DIODE	1SS355	△R	5424(A,107,70) CARBON FILM RESISTOR	RD1/4MUF4R7J
	D	5544(B,242,73) DIODE	1SS355	△R	5425(B,135,91) CHIP RESISTOR	ACN7132
C	CN5301(A,319,31)	13P SOCKET	XKP3077	△R	5426(B,99,91) CHIP RESISTOR	ACN7132
	CN5302(A,85,45)	11P SOCKET	XKP3076	△R	5427(A,114,80) RESISTOR (0.18, 5W)	ACN7121
	CN5303(A,312,68)	PLUG 6-P	KM250NA6L	R	5429(B,114,44)	RN1/10SE3302D
	CN5304(A,143,23)	CONNECTOR POST	B2B-PH	R	5430(B,119,45)	RN1/16SE1001D
	5002(A,236,21)	PCB BINDER	VEF1040	R	5431(B,119,43)	RN1/16SE1500D

## RESISTORS

	R	5301(B,192,43)	RS1/16S102J	R	5443(B,97,63)	RS1/16S471J
	R	5302(B,180,42)	RS1/16S221J	R	5444(B,91,63)	RS1/16S471J
	R	5303(B,177,41)	RS1/16S333J	R	5445(B,96,54)	RS1/16S472J
	R	5304(B,192,40)	RS1/16S103J	R	5446(B,92,54)	RS1/16S472J
D	R	5305(B,170,55)	RS1/16S152J	R	5447(B,88,49)	RS1/16S122J
	R	5306(B,168,47)	RS1/16S821J	R	5448(B,94,50)	RS1/16S154J
	R	5307(B,190,48)	RS1/16S2001F	R	5449(B,96,50)	RS1/16S103J
	R	5308(B,179,54)	RS1/16S682J	R	5450(B,96,46)	RS1/16S103J
	R	5309(A,183,48) CARBON FILM RESISTOR	RD1/2VM473J	R	5501(B,283,44)	RS1/16S102J
	R	5310(B,191,62)	RS1/16S151J	R	5502(B,270,42)	RS1/16S221J
	R	5311(B,188,62)	RN1/16SE1201D	R	5503(B,267,41)	RS1/16S333J
	R	5312(B,162,51)	RS1/16S221J	R	5504(B,283,40)	RS1/16S103J
	△R	5313(B,183,97)	RS1/16S330J	R	5505(B,260,55)	RS1/16S152J
	R	5321(B,190,93)	RS1/16S101J	R	5506(B,258,47)	RS1/16S821J
	R	5322(B,176,93)	RS1/16S101J	R	5507(B,281,48)	RS1/16S2001F
E	△R	5323(A,196,79) CARBON FILM RESISTOR	RD1/4MUF4R7J	R	5508(B,270,54)	RS1/16S682J
	△R	5324(A,161,70) CARBON FILM RESISTOR	RD1/4MUF4R7J	R	5509(A,273,48) CARBON FILM RESISTOR	RD1/2VM473J
	△R	5325(B,203,91) CHIP RESISTOR	ACN7132	R	5510(B,280,63)	RS1/16S151J
	△R	5326(B,166,91) CHIP RESISTOR	ACN7132	R	5511(B,277,63)	RN1/16SE1201D
	△R	5327(A,172,80) RESISTOR (0.18, 5W)	ACN7121	R	5512(B,253,51)	RS1/16S221J
	R	5329(B,168,44)	RN1/10SE3302D	△R	5513(B,257,97)	RS1/16S330J
	R	5330(B,173,45)	RN1/16SE1001D	R	5521(B,268,94)	RS1/16S101J
	R	5331(B,173,43)	RN1/16SE1500D	R	5522(B,251,93)	RS1/16S101J
	R	5332(B,160,51)	RS1/16S151J	△R	5523(A,280,82) CARBON FILM RESISTOR	RD1/4MUF4R7J
	R	5341(B,150,75)	RS1/16S473J	△R	5524(A,250,70) CARBON FILM RESISTOR	RD1/4MUF4R7J
F	R	5342(B,148,75)	RS1/16S223J	△R	5525(B,277,91) CHIP RESISTOR	ACN7132
	R	5343(B,153,75)	RS1/16S471J	△R	5526(B,241,91) CHIP RESISTOR	ACN7132
	R	5344(B,146,75)	RS1/16S471J	△R	5527(A,256,80) RESISTOR (0.18, 5W)	ACN7121
	R	5345(B,152,65)	RS1/16S472J	R	5529(B,258,44)	RN1/10SE3302D

Mark No.	Description	Part No.
R 5530(B,263,45)		RN1/16SE1001D
R 5531(B,263,43)		RN1/16SE1500D
R 5532(B,250,51)		RS1/16S151J
R 5541(B,241,77)		RS1/16S473J
R 5542(B,235,77)		RS1/16S223J
R 5543(B,239,77)		RS1/16S471J
R 5544(B,237,77)		RS1/16S471J
R 5545(B,240,64)		RS1/16S472J
R 5546(B,238,64)		RS1/16S472J
R 5547(B,238,57)		RS1/16S122J
R 5548(B,235,68)		RS1/16S154J
R 5549(B,236,64)		RS1/16S103J
R 5550(B,242,46)		RS1/16S103J
R 5571(B,226,38)		RS1/16S472J
△ R 5592(B,301,91)	CHIP RESISTOR	ACN7132
R 5622(B,311,93)		RS1/16S101J

### CAPACITORS

C 5301(A,183,43)		CEAT4R7M50
C 5302(B,177,43)		CCSRCH221J50
C 5304(B,167,51)		CKSRYB102K50
C 5307(A,195,53)		CEAT101M10
C 5308(B,164,51)	CAPACITOR(CERAMIC)	ACG7057
C 5309(A,179,58)	ELECT. CAPACITOR	CEAT100M2A
C 5311(B,197,104)	CAPACITOR(CERAMIC)	ACG7056
C 5312(B,170,104)	CAPACITOR(CERAMIC)	ACG7056
C 5315(B,168,41)		CCSRCH220J50
C 5316(B,168,39)		CCSRCH220J50
C 5317(A,172,39)		CEAT331M10
C 5323(A,190,66)		CEAT100M63
C 5324(A,165,62)		CEAT100M63
C 5332(B,162,47)		CKSRYB224K16
C 5341(A,145,66)		CEANP2R2M50
C 5351(A,226,68)	ELECT. CAPACITOR	CEAT100M2A
C 5352(A,222,62)	ELECT. CAPACITOR	CEAT100M2A
C 5401(A,129,43)		CEAT4R7M50
C 5402(B,123,43)		CCSRCH221J50
C 5404(B,113,51)		CKSRYB102K50
C 5407(A,141,53)		CEAT101M10
C 5408(B,111,51)	CAPACITOR(CERAMIC)	ACG7057
C 5409(A,125,58)	ELECT. CAPACITOR	CEAT100M2A
C 5411(B,130,104)	CAPACITOR(CERAMIC)	ACG7056
C 5412(B,101,104)	CAPACITOR(CERAMIC)	ACG7056
C 5415(B,114,41)		CCSRCH220J50
C 5416(B,114,39)		CCSRCH220J50
C 5417(A,119,39)		CEAT331M10
C 5423(A,137,66)		CEAT100M63
C 5424(A,111,62)		CEAT100M63
C 5432(B,108,47)		CKSRYB224K16
C 5441(A,88,53)		CEANP2R2M50
C 5501(A,273,43)		CEAT4R7M50
C 5502(B,267,43)		CCSRCH221J50
C 5504(B,257,51)		CKSRYB102K50
C 5507(A,284,54)		CEAT101M10
C 5508(B,255,51)	CAPACITOR(CERAMIC)	ACG7057
C 5509(A,267,58)	ELECT. CAPACITOR	CEAT100M2A
C 5511(B,271,104)	CAPACITOR(CERAMIC)	ACG7056
C 5512(B,243,104)	CAPACITOR(CERAMIC)	ACG7056
C 5515(B,258,41)		CCSRCH220J50

Mark No.	Description	Part No.
C 5516(B,258,39)		CCSRCH220J50
C 5517(A,263,39)		CEAT331M10
C 5523(A,289,64)		CEAT100M63
C 5524(A,254,62)		CEAT100M63
C 5532(B,252,47)		CKSRYB224K16
C 5541(A,238,54)		CEANP2R2M50
C 5571(A,229,35)		CEAT331M10
C 5612(B,307,104)	CAPACITOR(CERAMIC)	ACG7056

### AH POSI 1-R ASSY MISCELLANEOUS

△ TH 4503(A,54,235)	POSISTOR	PTFM04BH222Q2N34B0
J 4551(A,66,232)	CONNECTOR ASSY	PG02KS-E07

### AI POWER AMP IN ASSY MISCELLANEOUS

Q 5601(B,58,86)	CHIP TRANSISTOR	2SD2704K
Q 5602(B,46,41)	TRANSISTOR	IMT4
Q 5603(B,42,54)	CHIP TRANSISTOR	2SA1514K
△ Q 5604(A,32,55)	TRANSISTOR	2SA1145
Q 5605(A,33,38)	TRANSISTOR	2SC2705
Q 5641(B,11,26)	CHIP TR	2SA1255
△ D 5601(B,35,57)	CHIP ZENER DIODE	UDZS3R6(B)
△ D 5602(B,35,53)	DIODE	1SS355
△ D 5603(B,26,49)	DIODE	1SS355
△ D 5604(B,23,44)	DIODE	1SS355
△ D 5605(B,23,47)	DIODE	UDZS4R7(B)
△ D 5606(B,21,42)	DIODE	UDZS4R7(B)
D 5641(B,18,23)	DIODE	1SS355
D 5642(B,20,23)	DIODE	1SS355
D 5643(B,13,21)	DIODE	1SS355
D 5644(B,28,23)	DIODE	1SS355
CN5601(A,71,64)	13P PLUG	XKP3066
CN5602(A,56,31)	13P PLUG	XKP3066
CN5603(A,76,131)	19P CONNECTOR	52044-1945
CN5605(A,47,65)	SOCKET 6-P	KP250NA6
CN5606(A,34,31)	SOCKET 6-P	KP250NA6
5604(A,7,50)	5P CABLE HOLDER	51048-0500

### RESISTORS

R 5601(B,58,93)		RS1/16S102J
R 5602(B,54,41)		RS1/16S221J
R 5603(B,52,41)		RS1/16S333J
R 5604(B,57,82)		RS1/16S103J
R 5605(B,46,36)		RS1/16S152J
R 5606(B,41,38)		RS1/16S821J
R 5607(B,42,59)		RS1/16S2001F
R 5608(B,42,42)		RS1/16S682J
R 5609(A,32,46)	CARBON FILM RESISTOR	RD1/2VM473J
R 5610(B,30,59)		RS1/16S151J
R 5611(B,33,59)		RN1/16SE1201D
R 5612(B,33,34)		RS1/16S221J
△ R 5623(A,65,58)	CARBON FILM RESISTOR	RD1/4MUF4R7J
△ R 5624(A,65,40)	CARBON FILM RESISTOR	RD1/4MUF4R7J
△ R 5627(A,19,56)	RESISTOR (0.18, 5W)	ACN7121
R 5629(B,47,48)		RN1/10SE3302D
R 5630(B,49,46)		RN1/16SE1001D
R 5631(B,49,51)		RN1/16SE1500D

**Mark No. Description****Part No.**

R	5632(B,30,36)	RS1/16S151J
R	5641(B,14,43)	RS1/16S473J
A	R 5642(B,17,33)	RS1/16S223J
	R 5643(B,14,33)	RS1/16S471J
	R 5644(B,15,38)	RS1/16S471J
	R 5645(B,18,28)	RS1/16S472J
	R 5646(B,20,28)	RS1/16S472J
	R 5647(B,10,33)	RS1/16S122J
	R 5648(B,45,25)	RS1/16S154J
	R 5649(B,49,26)	RS1/16S103J
	R 5650(B,51,26)	RS1/16S103J

**Mark No. Description****Part No.**

R	5716(B,29,101)	RS1/16S472J
R	5717(B,33,95)	RS1/16S103J
R	5718(B,30,210)	RS1/16S104J
R	5720(B,31,95)	RS1/16S103J
R	5721(B,29,95)	RS1/16S683J
R	5746(B,20,181)	RS1/16S0R0J
R	5747(B,18,161)	RS1/16S0R0J
R	5750(B,35,95)	RS1/16S0R0J
R	5751(B,26,131)	RS1/16S0R0J
R	5752(B,25,101)	RS1/16S0R0J

**CAPACITORS**

B	C 5601(A,53,45)	CEAT4R7M50
	C 5602(B,50,41)	CCSRCH221J50
	C 5604(B,44,36)	CKSRYB102K50
	C 5607(A,38,57)	CEAT101M10
	C 5608(B,36,42) CAPACITOR(CERAMIC)	ACG7057
	C 5609(A,27,51) ELECT. CAPACITOR	CEAT100M2A
	C 5615(B,45,47)	CCSRCH220J50
	C 5616(B,42,49)	CCSRCH220J50
	C 5617(A,47,52)	CEAT331M10
	C 5623(A,69,58)	CEAT100M63
	C 5624(A,69,42)	CEAT100M63
C	C 5632(B,28,39)	CKSRYB224K16
	C 5641(A,12,35)	CEANP2R2M50

**CAPACITORS**

C	5701(B,13,181)	CKSRYB104K50
C	5702(B,15,181)	CKSRYB104K50
C	5703(B,23,110)	CKSRYB103K50
C	5704(B,23,114)	CKSRYB103K50
C	5705(B,31,101)	CKSRYB223K50
C	5706(B,37,217)	CKSRYB103K50

**AK HDMI ASSY****MISCELLANEOUS**

IC	101 (A,53,65) HDMI RECEIVER IC	SII9135CTU
IC	151 (A,34,85) EEPROM	BR24L02FV-W
IC	152 (A,27,84) IC	TC7MB3257FK
IC	171 (A,21,68) EEPROM	BR24L02FV-W
IC	172 (A,27,69) IC	TC7MB3257FK
IC	201 (A,82,35) IC	TC74LCX541FTS1
IC	202 (A,91,24) IC	TC74VHC125FTS1
IC	301 (A,51,31) HDMI TRANSMITTER IC	SII9134CTU
IC	401 (A,139,58) VIDEO DECODER IC	ADV7800BSTZ-80
IC	402 (A,162,66) LOGIC IC	TC7WHU04FU
IC	451 (A,79,73) IC	TC74LCX541FTS1
IC	452 (A,79,64) IC	TC74LCX541FTS1
IC	453 (A,79,54) IC	TC74LCX541FTS1
IC	454 (A,79,45) IC	TC74LCX541FTS1
IC	455 (A,80,79) IC	TC7SZ125FU
IC	501 (B,104,36) CPU	PEG118A
IC	502 (A,104,38) FLASH ROM	AYW7166
IC	503 (A,70,16) IC	TC74VHC125FTS1
IC	701 (A,105,59) VIDEO ENCODER IC	ADV7172KSTZ
△ IC	901 (A,71,32) IC	NJM2886DL3-33
△ IC	902 (A,147,22) IC	BD9850FVM
△ IC	903 (B,135,28) REGULATOR IC	NJM2845DL1-33
△ IC	904 (B,163,46) IC	NJM2885DL1-18
△ IC	905 (A,158,39) REGULATOR IC	NJM2845DL1-33
△ IC	911 (B,81,16) REGULATOR IC	NJM2872BF05

**AJ POWER PROTECT ASSY****MISCELLANEOUS**

IC	5701(B,19,110) OP-AMP IC	BA4560RF
Q	5701(B,26,161) TRANSISTOR	RT1N241M
Q	5702(B,16,161) DIGITAL TR(SC-70)	RT1P241M
Q	5703(B,16,151) TRANSISTOR	RT1N241M
Q	5704(B,33,100) TRANSISTOR	2SC4081
D	Q 5705(B,23,161) TRANSISTOR	RT1N241M
	Q 5706(B,12,161) DIGITAL TR(SC-70)	RT1P241M
D	5701(B,23,94) DIODE	1SS355
D	5702(B,30,205) DIODE	1SS355
	CN5701(A,28,171) 11P PLUG	XKP3065
	CN5702(A,15,138) 11P PLUG	XKP3065
	CN5703(A,8,85) 19P CONNECTOR	52044-1945
	CN5704(A,37,83) CONNECTOR	S5B-PH
	CN5705(A,30,223) 17P CONNECTOR	52044-1745
	CN5706(A,38,222) 3PIN CONNECTOR	S3B-EH

**RESISTORS**

R	5701(B,23,151)	RS1/16S562J
R	5702(B,21,151)	RS1/16S562J
R	5703(B,10,181)	RS1/16S473J
R	5705(B,18,187)	RS1/16S0R0J
R	5706(B,19,151)	RS1/16S822J
	R 5707(B,18,181)	RS1/16S473J
	R 5708(B,13,187)	RS1/16S0R0J
	R 5710(B,17,118)	RS1/16S223J
	R 5711(B,13,112)	RS1/16S103J
	R 5712(B,13,108)	RS1/16S472J
F	R 5713(B,23,106)	RS1/16S103J
	R 5714(B,24,131)	RS1/16S102J
	R 5715(B,27,101)	RS1/16S473J
Q	101 (B,59,71) DIGITAL TR(SC-70)	RT1N431M
Q	102 (B,56,71) DIGITAL TR(SC-70)	RT1P241M
Q	103 (B,59,66) DIGITAL TR(SC-70)	RT1N431M
Q	104 (B,56,66) DIGITAL TR(SC-70)	RT1P241M
Q	151 (B,18,91) CHIP TRANSISTOR	DTC114YUA
Q	152 (B,27,84) CHIP TRANSISTOR	DTC114YUA
Q	161 (A,40,90) DUAL MOS FET	HN1K02FU
Q	171 (B,20,55) CHIP TRANSISTOR	DTC114YUA
Q	172 (B,29,69) CHIP TRANSISTOR	DTC114YUA
Q	351 (A,28,46) CHIP TR (PNP X 2)	UMB1N
Q	352 (A,24,46) CHIP TRANSISTOR	DTC114YUA
Q	731 (A,92,70) TRANSISTOR	2SA1576A
Q	741 (A,97,70) TRANSISTOR	2SA1576A

5			6			7			8		
Mark No.	Description	Part No.	Mark No.	Description	Part No.	Mark No.	Description	Part No.	Mark No.	Description	Part No.
Q 751 (A,101,70)	TRANSISTOR	2SA1576A	R 109 (B,51,66)			R 109 (B,51,66)		RS1/16S102J			
Q 761 (A,106,70)	TRANSISTOR	2SA1576A	R 110 (B,53,66)			R 110 (B,53,66)		RS1/16S103J			
Q 771 (A,110,70)	TRANSISTOR	2SA1576A	R 111 (B,51,71)			R 111 (B,51,71)		RS1/16S102J			A
Q 781 (A,115,70)	TRANSISTOR	2SA1576A	R 112 (B,53,71)			R 112 (B,53,71)		RS1/16S103J			
△ Q 901 (A,153,19)	MOS FET	RTQ025P02	R 113 (A,42,49)			R 113 (A,42,49)		RS1/16S101J			
Q 902 (A,139,29)	CHIP TRANSISTOR	DTC114YUA	R 114 (A,45,51)	RESISTOR ARRAY		R 114 (A,45,51)	RESISTOR ARRAY	RAB4CQ680J			
Q 907 (A,138,25)	TRANSISTOR	2SC4081	R 115 (A,49,51)	RESISTOR ARRAY		R 115 (A,49,51)	RESISTOR ARRAY	RAB4CQ680J			
Q 908 (A,135,25)	CHIP TRANSISTOR	DTC114YUA	R 116 (B,47,52)			R 116 (B,47,52)		RS1/16S470J			
D 151 (A,42,85)	DIODE	DAN202U	R 117 (B,51,52)			R 117 (B,51,52)		RS1/16S100J			
D 171 (A,26,63)	DIODE	DAN202U	R 118 (A,45,48)	RESISTOR ARRAY		R 118 (A,45,48)	RESISTOR ARRAY	RAB4CQ473J			
D 301 (A,53,15)	DIODE	UDZS5R1(B)	R 119 (A,49,47)	RESISTOR ARRAY		R 119 (A,49,47)	RESISTOR ARRAY	RAB4CQ473J			
D 501 (A,87,39)	CHIP DIODE	RB501V-40	R 120 (B,45,52)			R 120 (B,45,52)		RS1/16S473J			
△ D 901 (A,151,15)	DIODE	RSX201L-30	R 121 (B,49,52)			R 121 (B,49,52)		RS1/16S473J			
D 903 (A,123,33)	DIODE	RB551V-30	R 122 (A,58,49)			R 122 (A,58,49)		RS1/16S105J			B
L 101 (B,74,76)	CHIP BEADS	ATL7010	R 123 (A,55,49)			R 123 (A,55,49)		RS1/16S152J			
L 102 (A,69,51)	CHIP BEADS	ATL7010	R 124 (B,58,61)			R 124 (B,58,61)		RS1/16S472J			
L 103 (A,41,82)	CHIP BEADS	ATL7010	R 125 (B,65,46)			R 125 (B,65,46)		RS1/16S471J			
L 104 (A,40,50)	CHIP BEADS	ATL7010	R 126 (B,64,52)			R 126 (B,64,52)		RS1/16S221J			
L 105 (B,52,61)	CHIP SOLID INDUCTOR	QTL1013	R 127 (B,62,52)			R 127 (B,62,52)		RS1/16S221J			
L 106 (B,54,61)	CHIP SOLID INDUCTOR	QTL1013	R 128 (B,63,61)			R 128 (B,63,61)		RS1/16S472J			
L 301 (A,40,16)	CHIP BEADS	ATL7010	R 130 (A,67,55)	RESISTOR ARRAY		R 130 (A,67,55)	RESISTOR ARRAY	RAB4CQ220J			
L 302 (A,69,45)	CHIP BEADS	ATL7010	R 131 (A,67,60)	RESISTOR ARRAY		R 131 (A,67,60)	RESISTOR ARRAY	RAB4CQ220J			
L 303 (A,36,27)	CHIP BEADS	ATL7010	R 132 (A,67,65)	RESISTOR ARRAY		R 132 (A,67,65)	RESISTOR ARRAY	RAB4CQ220J			
L 304 (A,38,39)	CHIP BEADS	ATL7010	R 133 (B,51,76)			R 133 (B,51,76)		RS1/16SOR0J			
L 305 (A,36,39)	CHIP BEADS	ATL7010	R 141 (A,40,73)	RESISTOR ARRAY		R 141 (A,40,73)	RESISTOR ARRAY	ACN1275			C
△ L 351 (A,22,29)	COIL COIL	ATH7022	R 142 (A,40,71)	RESISTOR ARRAY		R 142 (A,40,71)	RESISTOR ARRAY	ACN1275			
△ L 352 (A,22,32)	COIL COIL	ATH7022	R 143 (A,40,69)	RESISTOR ARRAY		R 143 (A,40,69)	RESISTOR ARRAY	ACN1275			
△ L 353 (A,22,34)	COIL COIL	ATH7022	R 144 (A,40,67)	RESISTOR ARRAY		R 144 (A,40,67)	RESISTOR ARRAY	ACN1275			
△ L 354 (A,22,37)	COIL COIL	ATH7022	R 145 (A,40,64)	RESISTOR ARRAY		R 145 (A,40,64)	RESISTOR ARRAY	ACN1275			
L 401 (A,121,84)	CHIP BEADS	ATL7010	R 146 (A,40,62)	RESISTOR ARRAY		R 146 (A,40,62)	RESISTOR ARRAY	ACN1275			
L 402 (A,149,38)	CHIP BEADS	ATL7010	R 147 (A,40,60)	RESISTOR ARRAY		R 147 (A,40,60)	RESISTOR ARRAY	ACN1275			
L 403 (A,152,73)	CHIP SOLID INDUCTOR	QTL1013	R 148 (A,40,58)	RESISTOR ARRAY		R 148 (A,40,58)	RESISTOR ARRAY	ACN1275			
L 404 (A,137,84)	CHIP BEADS	ATL7010	R 151 (B,30,86)			R 151 (B,30,86)		RS1/16S100J			
L 405 (A,161,72)	CHIP SOLID INDUCTOR	QTL1013	R 152 (B,32,86)			R 152 (B,32,86)		RS1/16S100J			
L 502 (A,134,29)	CHIP BEADS	ATL7010	R 153 (B,34,86)			R 153 (B,34,86)		RS1/16S101J			
L 701 (A,97,51)	CHIP BEADS	ATL7010	R 154 (B,30,81)			R 154 (B,30,81)		RS1/16S103J			D
L 702 (A,87,57)	CHIP BEADS	ATL7010	R 155 (B,32,81)			R 155 (B,32,81)		RS1/16S103J			
L 902 (A,158,14)	POWER INDUCTOR	ATH7047	R 156 (B,34,81)			R 156 (B,34,81)		RS1/16S103J			
L 903 (A,139,20)	CHIP BEADS	ATL7010	R 157 (B,18,83)			R 157 (B,18,83)		RS1/16S473J			
L 1001(A,69,24)	CHIP BEADS	ATL7010	R 161 (B,14,83)			R 161 (B,14,83)		RS1/16S102J			
JA 101 (A,13,79)	HDMI CONNECTOR	AKP1318	R 167 (B,21,87)			R 167 (B,21,87)		RS1/16SOR0J			
JA 102 (A,13,57)	HDMI CONNECTOR	AKP1318	R 168 (B,21,79)			R 168 (B,21,79)		RS1/16SOR0J			
JA 301 (A,13,35)	HDMI CONNECTOR	AKP1318	R 169 (A,29,65)			R 169 (A,29,65)		RS1/16SOR0J			
X 101 (A,56,46)	CRYSTAL RESONATOR	ASS7068	R 170 (B,32,66)			R 170 (B,32,66)		RS1/16SOR0J			
X 401 (A,161,58)	CRYSTAL RESONATOR	ASS7069	R 171 (B,25,70)			R 171 (B,25,70)		RS1/16S100J			
X 501 (A,109,30)	CERAMIC RESONATOR	XSS3004	R 172 (B,23,70)			R 172 (B,23,70)		RS1/16S100J			
CN501 (A,15,19)	7P FFC CONNECTOR	RKN1048	R 173 (B,21,70)			R 173 (B,21,70)		RS1/16S101J			E
CN1001(A,121,13)	30P SOCKET	XKP3092	R 174 (B,25,65)			R 174 (B,25,65)		RS1/16S103J			
CN1002(A,83,81)	23P SOCKET	XKP3082	R 175 (B,23,65)			R 175 (B,23,65)		RS1/16S103J			
			R 176 (B,21,65)			R 176 (B,21,65)		RS1/16S103J			
			R 177 (B,23,61)			R 177 (B,23,61)		RS1/16S473J			
			R 181 (B,20,59)			R 181 (B,20,59)		RS1/16S102J			
<b>RESISTORS</b>											
R 101 (A,67,70)	RESISTOR ARRAY	RAB4CQ220J	R 191 (A,18,92)			R 191 (A,18,92)		RS1/10S0R0J			
R 102 (B,55,76)		RS1/16S150J	R 192 (A,18,90)			R 192 (A,18,90)		RS1/10S0R0J			
R 103 (A,64,79)	RESISTOR ARRAY	RAB4CQ220J	R 193 (A,20,48)			R 193 (A,20,48)		RS1/10S0R0J			
R 104 (A,59,79)	RESISTOR ARRAY	RAB4CQ220J	R 194 (A,20,45)			R 194 (A,20,45)		RS1/10S0R0J			
R 105 (A,52,82)	RESISTOR ARRAY	RAB4CQ470J	R 201 (A,85,28)			R 201 (A,85,28)		RS1/16S470J			F
R 106 (A,49,82)		RS1/16S100J	R 202 (A,83,28)			R 202 (A,83,28)		RS1/16S470J			
R 107 (A,48,82)		RS1/16S100J	R 204 (A,81,28)	RESISTOR ARRAY		R 204 (A,81,28)	RESISTOR ARRAY	RAB4CQ470J			
R 108 (A,45,82)	RESISTOR ARRAY	RAB4CQ100J	R 205 (A,78,28)	RESISTOR ARRAY		R 205 (A,78,28)	RESISTOR ARRAY	RAB4CQ470J			

	<u>Mark No.</u>	<u>Description</u>	<u>Part No.</u>	<u>Mark No.</u>	<u>Description</u>	<u>Part No.</u>
	R 206 (A,97,25)		RS1/16S100J	R 438 (B,95,53)		RS1/16S473J
	R 207 (A,93,28)		RS1/16S470J	R 440 (A,132,38)	RESISTOR ARRAY	RAB4CQ473J
A	R 208 (A,89,28)		RS1/16S470J	R 441 (A,128,38)	RESISTOR ARRAY	RAB4CQ473J
	R 209 (A,86,25)		RS1/16S470J	R 442 (A,119,43)	RESISTOR ARRAY	RAB4CQ473J
	R 210 (A,97,21)		RS1/16S0R0J	R 443 (A,117,53)	RESISTOR ARRAY	RAB4CQ473J
	R 301 (A,55,42)		RS1/16S100J	R 444 (B,124,51)		RS1/16S473J
	R 302 (A,46,42)		RS1/16S101J	R 445 (B,124,55)		RS1/16S473J
	R 303 (A,44,42)		RS1/16S471J	R 446 (A,119,55)	RESISTOR ARRAY	RAB4CQ473J
	R 304 (A,41,42)	CHIP RESISTOR	RS1/16S6800F	R 447 (A,119,59)	RESISTOR ARRAY	RAB4CQ473J
	R 305 (A,39,43)		RS1/16S180J	R 448 (A,124,37)		RS1/16S473J
	R 307 (B,40,33)		RS1/16S100J	R 449 (A,124,39)		RS1/16S473J
	R 308 (B,42,33)		RS1/16S100J	R 451 (A,74,72)	RESISTOR ARRAY	RAB4CQ680J
	R 309 (B,40,29)		RS1/16S100J	R 453 (A,74,63)		RAB4CQ330J
B	R 310 (B,43,24)		RS1/16S100J	R 454 (A,74,66)		RAB4CQ330J
	R 311 (A,41,20)		RS1/16S472J	R 455 (A,74,54)		RAB4CQ330J
	R 313 (A,53,17)		RS1/16S102J	R 456 (A,74,57)		RAB4CQ330J
	R 314 (A,49,16)		RS1/16S472J	R 457 (A,74,44)		RAB4CQ330J
	R 315 (B,58,33)		RS1/16S150J	R 458 (A,74,47)		RAB4CQ330J
	R 331 (A,61,42)	RESISTOR ARRAY	RAB4CQ473J	R 460 (A,78,79)		RS1/16S330J
	R 332 (B,60,33)		RS1/16S473J	R 461 (A,163,62)		RS1/16S105J
	R 333 (A,64,37)	RESISTOR ARRAY	RAB4CQ473J	R 462 (A,160,62)		RS1/16S102J
	R 334 (A,64,29)	RESISTOR ARRAY	RAB4CQ473J	R 463 (A,159,65)		RS1/16S101J
	R 335 (A,64,26)	RESISTOR ARRAY	RAB4CQ473J	R 501 (B,124,40)		RS1/16S101J
	R 336 (A,56,18)	RESISTOR ARRAY	RAB4CQ473J	R 502 (B,124,46)		RS1/16S101J
C	R 337 (A,50,18)	RESISTOR ARRAY	RAB4CQ473J	R 504 (B,128,28)		RS1/16S102J
	R 338 (A,47,18)	RESISTOR ARRAY	RAB4CQ473J	R 505 (B,122,32)		RS1/16S221J
	R 351 (A,28,48)		RS1/16S472J	R 508 (B,126,23)		RS1/16S101J
	R 352 (A,28,43)		RS1/16S472J	R 514 (B,110,22)		RS1/16S101J
	R 353 (A,26,46)		RS1/16S272J	R 517 (B,106,19)		RS1/16S100J
	R 354 (A,30,46)		RS1/16S272J	R 518 (B,104,19)		RS1/16S100J
	R 357 (A,32,46)		RS1/16S0R0J	R 519 (B,88,18)		RS1/16S100J
	R 358 (A,36,46)		RS1/16S0R0J	R 520 (B,82,23)		RS1/16S100J
	R 386 (B,18,38)		RS1/16S473J	R 521 (B,92,22)		RS1/16S101J
	R 391 (B,20,29)		RS1/10S0R0J	R 523 (B,90,22)		RS1/16S470J
	R 392 (B,23,29)		RS1/10S0R0J	R 524 (B,76,32)		RS1/16S101J
D	R 401 (B,135,51)		RS1/16S100J	R 525 (B,80,32)		RS1/16S101J
	R 402 (A,136,42)		RS1/16S470J	R 526 (B,78,32)		RS1/16S101J
	R 403 (B,137,51)		RS1/16S470J	R 527 (B,85,33)		RS1/16S101J
	R 404 (A,138,42)		RS1/16S470J	R 530 (B,122,40)		RS1/16S101J
	R 405 (A,139,42)		RS1/16S470J	R 541 (B,129,43)		RS1/16S103J
	R 412 (B,152,65)		RS1/16S471J	R 542 (B,128,32)		RS1/16S223J
	R 413 (A,157,74)		RS1/16S132J	R 543 (B,124,32)		RS1/16S103J
	R 414 (A,157,71)		RS1/16S391J	R 544 (B,116,27)		RS1/16S472J
	R 415 (A,154,74)		RS1/16S151J	R 545 (B,118,27)		RS1/16S103J
	R 416 (A,154,71)		RS1/16S100J	R 546 (B,124,27)		RS1/16S103J
	R 417 (B,147,71)		RS1/16S103J	R 548 (B,120,23)		RS1/16S103J
E	R 418 (B,145,71)		RS1/16S272J	R 549 (B,113,22)		RS1/16S103J
	R 419 (B,143,71)		RS1/16S272J	R 550 (A,102,23)		RS1/16S103J
	R 421 (B,157,74)		RS1/10S0R0J	R 551 (A,112,25)		RS1/16S103J
	R 422 (A,157,76)		RS1/10S0R0J	R 553 (A,104,22)		RS1/16S103J
	R 424 (B,132,73)		RS1/16S103J	R 555 (B,108,19)		RS1/16S222J
	R 425 (A,135,74)		RS1/16S330J	R 556 (B,102,19)		RS1/16S222J
	R 426 (A,133,74)		RS1/16S330J	R 557 (B,78,23)		RS1/16S222J
	R 428 (A,123,59)	RESISTOR ARRAY	RAB4CQ220J	R 558 (B,80,23)		RS1/16S222J
	R 429 (A,123,55)	RESISTOR ARRAY	RAB4CQ220J	R 559 (B,88,25)		RS1/16S473J
	R 432 (A,120,49)		RAB4CQ330J	R 560 (B,84,26)		RS1/16S473J
F	R 433 (A,122,46)		RAB4CQ330J	R 562 (B,82,26)		RS1/16S473J
	R 434 (A,128,41)	RESISTOR ARRAY	RAB4CQ220J	R 563 (B,80,26)		RS1/16S103J
	R 435 (A,132,41)	RESISTOR ARRAY	RAB4CQ220J	R 564 (B,113,51)		RS1/16S103J
	R 437 (A,138,38)	RESISTOR ARRAY	RAB4CQ473J	R 565 (B,122,47)		RS1/16S472J

5	6	7	8
<u>Mark No.</u>	<u>Description</u>	<u>Part No.</u>	<u>Mark No.</u> <u>Description</u> <u>Part No.</u>
R 566 (B,84,23)		RS1/16S103J	
R 571 (A,116,42)		RS1/16S473J	
R 572 (A,76,16)		RS1/16S470J	
R 573 (A,64,18)		RS1/16S470J	
R 574 (A,64,17)		RS1/16S472J	
R 575 (A,64,14)		RS1/16S470J	
R 576 (A,64,15)		RS1/16S103J	
R 577 (A,21,21)		RS1/16S103J	
R 584 (A,120,23)		RS1/16S0R0J	
R 702 (A,113,54)		RS1/16S103J	
R 704 (A,113,55)		RS1/16S103J	
R 705 (A,116,57)		RS1/16S103J	
R 706 (A,113,58)		RS1/16S103J	
R 707 (A,116,59)		RS1/16S470J	
R 708 (A,116,60)		RS1/16S470J	
R 709 (A,116,63)		RS1/16S1201F	
R 710 (A,116,62)		RS1/16S1201F	
R 711 (A,97,62)		RS1/16S1201F	
R 712 (A,97,64)		RS1/16S1201F	
R 713 (B,94,59)		RS1/16S470J	
R 714 (B,97,59)		RS1/16S103J	
R 716 (A,97,60)		RS1/16S103J	
R 718 (A,96,58)		RS1/16S103J	
R 719 (A,90,58)		RS1/16S471J	
R 721 (A,97,54)		RS1/16S0R0J	
R 731 (B,93,66)		RS1/16S1500F	
R 732 (B,91,66)		RS1/16S0R0J	
R 733 (A,91,74)		RS1/16S102J	
R 741 (B,98,66)		RS1/16S1500F	
R 742 (B,96,66)		RS1/16S0R0J	
R 743 (A,96,74)		RS1/16S102J	
R 751 (B,102,66)		RS1/16S1500F	
R 752 (B,100,66)		RS1/16S0R0J	
R 753 (A,100,74)		RS1/16S102J	
R 761 (B,107,66)		RS1/16S1500F	
R 762 (B,105,66)		RS1/16S3R3J	
R 763 (A,105,74)		RS1/16S102J	
R 771 (B,111,66)		RS1/16S1500F	
R 772 (B,109,66)		RS1/16S3R3J	
R 773 (A,109,74)		RS1/16S102J	
R 781 (B,116,66)		RS1/16S1500F	
R 782 (B,114,66)		RS1/16S3R3J	
R 783 (A,114,74)		RS1/16S102J	
R 901 (A,148,19)		RS1/16S330J	
R 902 (A,147,29)		RS1/16S2402F	
R 903 (B,148,26)		RS1/16S3002F	
R 904 (B,146,26)		RS1/16S0R0J	
R 905 (A,147,31)		RS1/16S561J	
R 906 (A,147,28)		RS1/16S222J	
R 907 (B,142,26)		RS1/16S1802F	
R 908 (B,144,26)		RS1/16S0R0J	
R 910 (B,135,15)		RS1/10S0R0J	
R 918 (A,142,28)		RS1/16S682J	
R 919 (A,142,24)		RS1/16S103J	
R 920 (A,136,32)		RS1/16S103J	
R 921 (A,132,24)		RS1/16S0R0J	
R 931 (B,74,24)		RS1/16S101J	
R 1002(A,69,22)		RS1/10S100J	
R 1101(B,88,73)		RS1/10S0R0J	
R 1102(B,86,73)		RS1/10S0R0J	
<b>CAPACITORS</b>			
C 101 (B,67,71)	CHIP CERAMIC C.	DCH1165	A
C 102 (A,66,51)	CHIP CERAMIC C.	DCH1165	
C 103 (A,41,80)		DCH1201	
C 104 (A,38,50)		DCH1201	
C 105 (A,61,79)		CKSRYB105K16	
C 106 (A,57,79)		CKSRYB104K16	
C 107 (A,53,79)		CKSRYB104K16	
C 108 (A,50,79)		CKSRYB104K16	
C 109 (B,49,66)		CKSRYB103K50	
C 110 (A,46,79)		CKSRYB104K16	
C 111 (B,49,71)		CKSRYB103K50	
C 112 (A,64,51)		CKSRYB105K16	B
C 113 (A,41,78)		CKSRYB105K16	
C 114 (B,43,71)		CKSRYB104K16	
C 115 (B,46,69)		CKSRYB104K16	
C 116 (B,43,67)		CKSRYB104K16	
C 117 (B,46,65)		CKSRYB105K16	
C 118 (B,43,62)		CKSRYB104K16	
C 119 (B,46,60)		CKSRYB104K16	
C 120 (B,43,58)		CKSRYB104K16	
C 121 (B,43,54)		CKSRYB105K16	
C 122 (A,42,51)		CKSRYB105K16	
C 123 (A,47,51)		CKSRYB104K16	C
C 124 (A,52,51)		CKSRYB104K16	
C 125 (A,53,51)		CKSRYB104K16	
C 126 (A,55,51)		CKSRYB104K16	
C 127 (B,53,46)		CCSRCH120J50	
C 128 (B,60,46)		CCSRCH100D50	
C 129 (B,50,61)		CKSRYB105K16	
C 130 (B,56,61)		CKSRYB105K16	
C 131 (B,63,46)		CKSRYB103K50	
C 132 (A,61,51)		CKSRYB104K16	
C 133 (A,62,51)		CKSRYB105K16	
C 134 (A,67,58)		CKSRYB104K16	D
C 135 (A,67,62)		CKSRYB104K16	
C 136 (A,67,63)		CKSRYB104K16	
C 137 (A,67,68)		CKSRYB104K16	
C 138 (A,67,72)		CKSRYB104K16	
C 139 (A,67,75)		CKSRYB104K16	
C 151 (A,34,82)		CKSRYB104K16	
C 152 (A,24,86)		CKSRYB104K16	
C 153 (A,39,85)		DCH1201	
C 171 (A,17,68)		CKSRYB104K16	
C 172 (A,24,70)		CKSRYB104K16	
C 173 (A,30,61)		DCH1201	E
C 201 (A,86,35)		CKSRYB104K16	
C 202 (A,88,20)		CKSRYB104K16	
C 301 (A,44,15)	CHIP CERAMIC C.	DCH1165	
C 302 (A,66,45)	CHIP CERAMIC C.	DCH1165	
C 303 (A,40,26)		DCH1201	
C 304 (A,39,39)		DCH1201	
C 305 (A,34,39)		DCH1201	
C 306 (A,52,42)		CKSRYB104K16	
C 307 (A,50,42)		CKSRYB105K16	
C 308 (A,43,42)		CKSRYB103K50	F
C 309 (A,40,45)		CKSRYB104K16	
C 310 (A,41,39)		CKSRYB105K16	

<u>Mark No.</u>	<u>Description</u>	<u>Part No.</u>	<u>Mark No.</u>	<u>Description</u>	<u>Part No.</u>
C 311 (B,47,34)		CKSRYB104K16	C 455 (A,79,82)		CKSRYB104K16
C 312 (B,44,32)		CKSRYB105K16	C 461 (A,162,70)		CKSRYB104K16
C 313 (B,47,29)		CKSRYB104K16	C 462 (A,164,61)		CCSRCH100D50
A					
C 314 (A,45,20)		CKSRYB105K16	C 463 (A,159,61)		CCSRCH120J50
C 315 (A,52,20)		CKSRYB104K16	C 501 (A,129,30)		CEVW101M16
C 316 (A,54,20)		CKSRYB104K16	C 502 (B,113,27)		CKSRYB104K16
C 317 (A,62,24)		CKSRYB105K16	C 503 (B,94,45)		CKSRYB104K16
C 318 (A,61,31)		CKSRYB104K16	C 504 (B,119,44)		CKSRYB104K16
C 319 (A,61,37)		CKSRYB105K16	C 505 (B,120,32)		CKSRYB103K50
C 351 (B,21,38)		CKSRYB104K16	C 511 (A,91,40)		CKSRYB104K16
C 401 (A,121,78)		CEVW101M16	C 512 (A,116,39)		CKSRYB105K16
C 402 (A,143,36)		CEVW101M16	C 513 (A,70,12)		CKSRYB104K16
C 403 (A,135,42)		CKSRYB104K16	C 514 (A,21,18)		CKSRYB104K16
B					
C 404 (A,141,42)		CKSRYB105K16	C 701 (A,92,52)		CEVW101M16
C 405 (A,146,42)		CKSRYB104K16	C 702 (A,99,51)		CKSRYB104K16
C 406 (A,147,42)		CKSRYB104K16	C 703 (A,110,51)		CKSRYB104K16
C 407 (A,155,48)		CKSRYB104K16	C 704 (A,113,60)		CKSRYB104K16
C 408 (A,155,53)		CKSRYB104K16	C 705 (A,116,65)		CKSRYB104K16
C 409 (A,155,55)		CKSRYB104K16	C 706 (B,108,59)		CKSRYB104K16
C 410 (A,155,62)		CKSRYB104K16	C 707 (B,106,59)		CKSRYB104K16
C 411 (A,155,64)		CKSRYB104K16	C 708 (B,104,59)		CKSRYB104K16
C 412 (B,154,65)		CKSRYB103K50	C 709 (B,99,60)		CKSRYB104K16
C 413 (A,159,74) CHIP CAPACITOR		CKSRYB823K25	C 710 (B,102,59)		CKSRYB105K16
C 414 (A,159,70)		CKSRYB103K50	C 711 (A,88,64)		CEVW101M16
C 415 (A,156,74)		CKSRYB824K10	C 712 (A,97,65)		CKSRYB104K16
C 416 (A,156,70)		CKSRYB393K16	C 713 (A,93,58)		CKSRYB103K50
C 417 (A,151,76)		DCH1201	C 714 (A,95,57)		CKSRYB104K16
C 418 (A,155,66)		CKSRYB104K16	C 731 (A,91,72)		CKSRYB104K16
C 421 (A,149,74)		CKSRYB102K50	C 741 (A,96,72)		CKSRYB104K16
C 422 (A,148,74)		CKSRYB104K16	C 751 (A,100,72)		CKSRYB104K16
C 423 (A,146,74)		CKSRYB104K16	C 761 (A,105,72)		CKSRYB104K16
C 424 (A,145,74)		CKSRYB104K16	C 771 (A,109,72)		CKSRYB104K16
C 425 (A,140,74)		CKSRYB104K16	C 781 (A,114,72)		CKSRYB104K16
C 426 (A,138,74)		CKSRYB104K16	C 901 (A,74,21)		CKSRYB105K16
C 427 (A,137,74)		CKSRYB104K16	C 902 (A,75,24)		CKSQYB225K10
C 428 (A,143,74)		CKSRYB104K16	C 903 (A,137,12)		DCH1201
C 429 (A,141,78)		CKSRYB104K16	C 905 (A,144,21)		DCH1201
C 430 (A,141,82)		CEVW100M16	C 906 (A,150,21)		CKSRYB105K16
C 431 (A,146,78)		CKSRYB104K16	C 907 (A,145,30)		CCSRCH821J50
C 432 (A,146,82)		CEVW100M16	C 909 (A,145,27)		CKSRYB472K50
C 433 (A,137,79)		CKSRYB105K16	C 910 (A,143,24)		CKSRYB103K50
C 434 (A,131,81)		CEVW101M16	C 911 (B,149,19)		DCH1201
C 435 (B,140,61)		CKSRYB103K50	C 912 (A,159,19)		DCH1201
C 436 (B,140,65)		CKSRYB103K50	C 913 (A,159,21)		DCH1201
C 437 (B,142,61)		CKSRYB104K16	C 915 (A,140,24)		CKSRYB104K16
C 438 (B,142,65)		CKSRYB104K16	C 921 (B,135,20)		CKSRYB105K16
C 439 (B,144,61)		DCH1201	C 922 (B,129,22)		CKSQYB225K10
C 440 (B,144,65)		DCH1201	C 923 (B,162,37)		CKSRYB105K16
C 441 (B,147,56)		CKSRYB104K16	C 924 (B,158,38) CHIP CERAMIC C.		DCG1028
C 442 (B,147,61)		CKSRYB104K16	C 925 (B,84,16)		CKSRYB105K16
C 443 (B,147,65)		CKSRYB104K16	C 926 (B,76,11)		CKSRYB103K50
C 445 (A,123,66)		CKSRYB104K16	C 927 (B,77,16)		CKSQYB225K10
C 446 (A,123,63)		CKSRYB104K16	C 928 (A,161,34)		CKSRYB105K16
C 447 (A,123,57)		CKSRYB104K16	C 929 (A,163,44)		CKSQYB225K10
C 448 (A,123,49)		CKSRYB104K16	C 1001(B,132,15)		CKSRYB104K16
C 449 (A,124,46)		CKSRYB104K16	C 1002(A,131,13)		CEVW101M16
C 451 (A,79,69)		CKSRYB104K16	C 1025(A,80,16)		CKSRYB104K16
C 452 (A,79,59)		CKSRYB104K16	C 1026(A,80,17)		CKSRYB102K50
C 453 (A,79,50)		CKSRYB104K16	C 1028(B,124,12)		CKSRYB104K16
C 454 (A,77,40)		CKSRYB104K16	C 1029(B,126,12)		CKSRYB102K50



<u>Mark No.</u>	<u>Description</u>	<u>Part No.</u>
C	742 (A,92,24)	CKSRYB104K16
C	743 (A,93,27)	CKSQYB225K10
C	744 (A,97,26)	CEJQ470M10
A		
C	745 (A,65,31)	CKSQYB105K16
C	746 (A,67,28)	CKSQYB475K6R3
C	747 (A,34,48)	CKSSYB104K10
C	748 (A,33,48)	CKSSYB471K50
C	751 (A,45,17)	CKSSYB104K10
C	752 (A,62,16)	CKSSYB104K10
C	761 (A,76,39)	CKSSYB104K10
C	762 (A,77,39)	CKSSYB471K50
C	763 (A,71,39)	CKSSYB471K50
C	764 (A,67,40)	CKSSYB471K50
B		
C	766 (A,57,40)	CKSSYB471K50
C	767 (A,90,55)	CKSSYB104K10
C	768 (A,90,54)	CKSSYB471K50
C	769 (A,43,55)	CKSRYB104K16
C	771 (A,71,25)	CKSQYB105K16
C	773 (A,64,23)	CKSRYB104K16
C	952 (A,57,17)	CKSRYB104K16

## FM/AM TUNER UNIT

FM/AM TUNER UNIT has no service part.